

# COURSE MATERIAL

III Year B. Tech I- Semester  
MECHANICAL ENGINEERING

AY: 2024-25



---

DESIGN OF MACHINE  
ELEMENTS

R22A0314

---



Prepared by:  
Mr. D. Mani Kumar  
Assistant Professor



**MALLA REDDY COLLEGE OF ENGINEERING & TECHNOLOGY**

**DEPARTMENT OF MECHANICAL ENGINEERING**

(Autonomous Institution-UGC, Govt. of India)  
Secunderabad-500100, Telangana State, India.

[www.mrcet.ac.in](http://www.mrcet.ac.in)



# MALLA REDDY COLLEGE OF ENGINEERING & TECHNOLOGY

(Autonomous Institution – UGC, Govt. of India)

## DEPARTMENT OF MECHANICAL ENGINEERING

---

### CONTENTS

1. Vision, Mission & Quality Policy
2. Pos, PSOs & PEOs
3. Blooms Taxonomy
4. Course Syllabus
5. Lecture Notes (Unit wise)
  - a. Objectives and outcomes
  - b. Notes
  - c. Presentation Material (PPT Slides/ Videos)
  - d. Industry applications relevant to the concepts covered
  - e. Question Bank for Assignments
  - f. Tutorial Questions
6. Previous Question Papers



# MALLA REDDY COLLEGE OF ENGINEERING & TECHNOLOGY

(Autonomous Institution – UGC, Govt. of India)

---

## VISION

- ❖ To establish a pedestal for the integral innovation, team spirit, originality and competence in the students, expose them to face the global challenges and become technology leaders of Indian vision of modern society.

## MISSION

- ❖ To become a model institution in the fields of Engineering, Technology and Management.
- ❖ To impart holistic education to the students to render them as industry ready engineers.
- ❖ To ensure synchronization of MRCET ideologies with challenging demands of International Pioneering Organizations.

## QUALITY POLICY

- ❖ To implement best practices in Teaching and Learning process for both UG and PG courses meticulously.
- ❖ To provide state of art infrastructure and expertise to impart quality education.
- ❖ To groom the students to become intellectually creative and professionally competitive.
- ❖ To channelize the activities and tune them in heights of commitment and sincerity, the requisites to claim the never - ending ladder of **SUCCESS** year after year.

For more information: [www.mrcet.ac.in](http://www.mrcet.ac.in)

# MALLA REDDY COLLEGE OF ENGINEERING & TECHNOLOGY

(Autonomous Institution – UGC, Govt. of India)

[www.mrcet.ac.in](http://www.mrcet.ac.in)

**Department of Mechanical Engineering**

---

## **VISION**

To become an innovative knowledge center in mechanical engineering through state-of-the-art teaching-learning and research practices, promoting creative thinking professionals.

## **MISSION**

The Department of Mechanical Engineering is dedicated for transforming the students into highly competent Mechanical engineers to meet the needs of the industry, in a changing and challenging technical environment, by strongly focusing in the fundamentals of engineering sciences for achieving excellent results in their professional pursuits.

## **Quality Policy**

- ✓ To pursuit global Standards of excellence in all our endeavors namely teaching, research and continuing education and to remain accountable in our core and support functions, through processes of self-evaluation and continuous improvement.
- ✓ To create a midst of excellence for imparting state of art education, industry-oriented training research in the field of technical education.

# MALLA REDDY COLLEGE OF ENGINEERING & TECHNOLOGY

(Autonomous Institution – UGC, Govt. of India)

[www.mrcet.ac.in](http://www.mrcet.ac.in)

Department of Mechanical Engineering

---

## PROGRAM OUTCOMES

Engineering Graduates will be able to:

- 1. Engineering knowledge:** Apply the knowledge of mathematics, science, engineering fundamentals, and an engineering specialization to the solution of complex engineering problems.
- 2. Problem analysis:** Identify, formulate, review research literature, and analyze complex engineering problems reaching substantiated conclusions using first principles of mathematics, natural sciences, and engineering sciences.
- 3. Design/development of solutions:** Design solutions for complex engineering problems and design system components or processes that meet the specified needs with appropriate consideration for the public health and safety, and the cultural, societal, and environmental considerations.
- 4. Conduct investigations of complex problems:** Use research-based knowledge and research methods including design of experiments, analysis and interpretation of data, and synthesis of the information to provide valid conclusions.
- 5. Modern tool usage:** Create, select, and apply appropriate techniques, resources, and modern engineering and IT tools including prediction and modeling to complex engineering activities with an understanding of the limitations.
- 6. The engineer and society:** Apply reasoning informed by the contextual knowledge to assess societal, health, safety, legal and cultural issues and the consequent responsibilities relevant to the professional engineering practice.
- 7. Environment and sustainability:** Understand the impact of the professional engineering solutions in societal and environmental contexts, and demonstrate the knowledge of, and need for sustainable development.
- 8. Ethics:** Apply ethical principles and commit to professional ethics and responsibilities and norms of the engineering practice.
- 9. Individual and teamwork:** Function effectively as an individual, and as a member or leader in diverse teams, and in multidisciplinary settings.
- 10. Communication:** Communicate effectively on complex engineering activities with the engineering community and with society at large, such as, being able to comprehend and write effective reports and design documentation, make effective presentations, and give and receive clear instructions.
- 11. Project management and finance:** Demonstrate knowledge and understanding of the engineering and management principles and apply these to one's own work, as a member and leader in a team, to manage projects and in multidisciplinary environments.

# MALLA REDDY COLLEGE OF ENGINEERING & TECHNOLOGY

(Autonomous Institution – UGC, Govt. of India)

www.mrcet.ac.in

## Department of Mechanical Engineering

---

**12. Life-long learning:** Recognize the need for and have the preparation and ability to engage in independent and life-long learning in the broadest context of technological change.

### PROGRAM SPECIFIC OUTCOMES (PSOs)

- PSO1** Ability to analyze, design and develop Mechanical systems to solve the Engineering problems by integrating thermal, design and manufacturing Domains.
- PSO2** Ability to succeed in competitive examinations or to pursue higher studies or research.
- PSO3** Ability to apply the learned Mechanical Engineering knowledge for the Development of society and self.

### Program Educational Objectives (PEOs)

The Program Educational Objectives of the program offered by the department are broadly listed below:

#### PEO1: PREPARATION

To provide sound foundation in mathematical, scientific and engineering fundamentals necessary to analyze, formulate and solve engineering problems.

#### PEO2: CORE COMPETANCE

To provide thorough knowledge in Mechanical Engineering subjects including theoretical knowledge and practical training for preparing physical models pertaining to Thermodynamics, Hydraulics, Heat and Mass Transfer, Dynamics of Machinery, Jet Propulsion, Automobile Engineering, Element Analysis, Production Technology, Mechatronics etc.

#### PEO3: INVENTION, INNOVATION AND CREATIVITY

To make the students to design, experiment, analyze, interpret in the core field with the help of other inter disciplinary concepts wherever applicable.

#### PEO4: CAREER DEVELOPMENT

To inculcate the habit of lifelong learning for career development through successful completion of advanced degrees, professional development courses, industrial training etc.

# **MALLA REDDY COLLEGE OF ENGINEERING & TECHNOLOGY**

(Autonomous Institution – UGC, Govt. of India)

[www.mrcet.ac.in](http://www.mrcet.ac.in)

**Department of Mechanical Engineering**

---

## **PEO5: PROFESSIONALISM**

To impart technical knowledge, ethical values for professional development of the student to solve complex problems and to work in multi-disciplinary ambience, whose solutions lead to significant societal benefits.

# MALLA REDDY COLLEGE OF ENGINEERING & TECHNOLOGY

(Autonomous Institution – UGC, Govt. of India)

[www.mrcet.ac.in](http://www.mrcet.ac.in)

Department of Mechanical Engineering

---

## Blooms Taxonomy

Bloom's Taxonomy is a classification of the different objectives and skills that educators set for their students (learning objectives). The terminology has been updated to include the following six levels of learning. These 6 levels can be used to structure the learning objectives, lessons, and assessments of a course.

1. **Remembering:** Retrieving, recognizing, and recalling relevant knowledge from long-term memory.
2. **Understanding:** Constructing meaning from oral, written, and graphic messages through interpreting, exemplifying, classifying, summarizing, inferring, comparing, and explaining.
3. **Applying:** Carrying out or using a procedure for executing or implementing.
4. **Analyzing:** Breaking material into constituent parts, determining how the parts relate to one another and to an overall structure or purpose through differentiating, organizing, and attributing.
5. **Evaluating:** Making judgments based on criteria and standard through checking and critiquing.
6. **Creating:** Putting elements together to form a coherent or functional whole; reorganizing elements into a new pattern or structure through generating, planning, or producing.



# MALLA REDDY COLLEGE OF ENGINEERING & TECHNOLOGY

(Autonomous Institution – UGC, Govt. of India)

[www.mrcet.ac.in](http://www.mrcet.ac.in)

Department of Mechanical Engineering

---

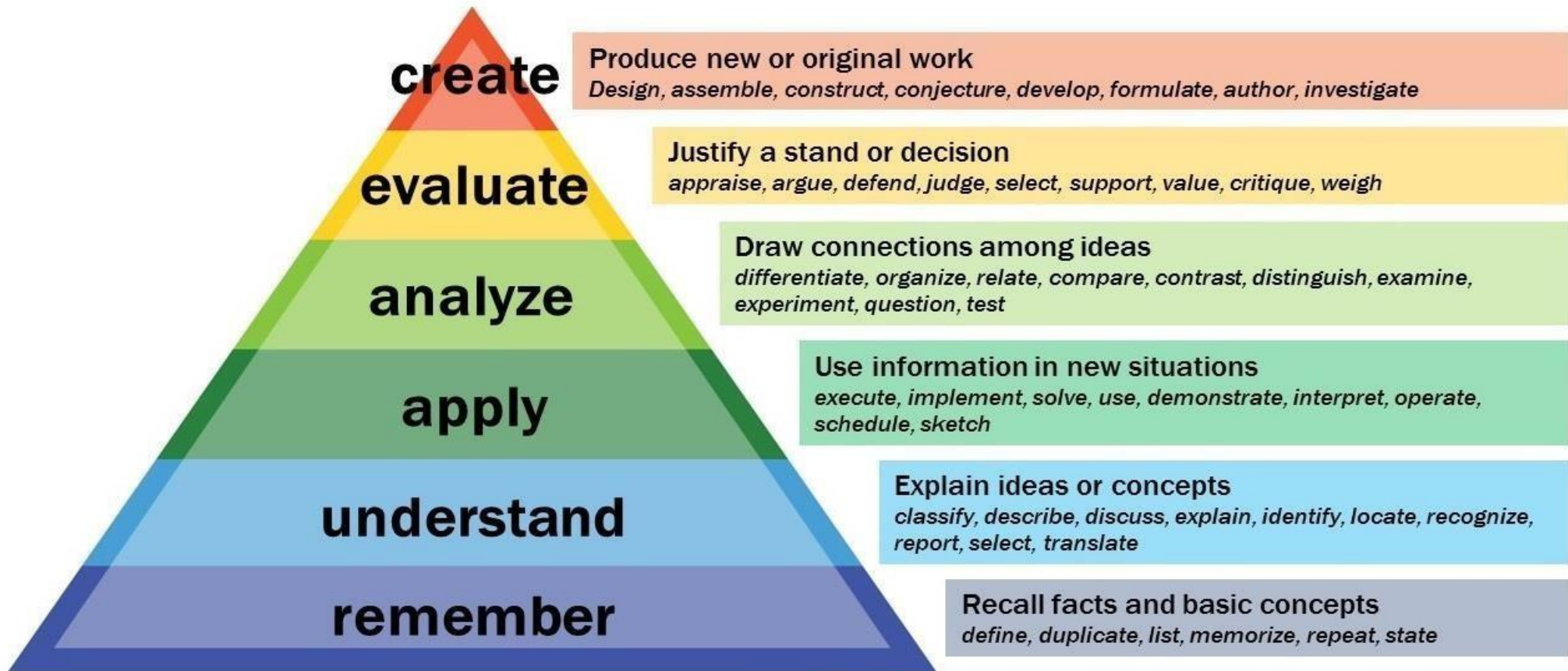

---

**MALLA REDDY COLLEGE OF ENGINEERING AND TECHNOLOGY**  
**III Year B.Tech. ME- I Sem**

**L/T/P/C**  
**3/-/-/3**

**(R22A0314) DESIGN OF MACHINE ELEMENTS**  
**(Professional Elective I)**

**COURSE OBJECTIVES:**

1. To apply the various design procedures, principles and various stresses in the design of machine elements. To apply different materials of construction and their properties and factors determining the selection of material for various applications.
2. To develop good and careful problem formulation and solution skills for designing selected machine components and systems
3. To learn the design of temporary and Permanent Joints.
4. To learn the design Procedure for the different Shafts under loading condition, able to know various shafts coupling.
5. To apply the design procedure of support rotating element.

**UNIT I**

**Fundamentals of design and Stresses in Machine Members:** General considerations in the design of Engineering Materials and their properties – selection – Manufacturing consideration in design. BIS codes of steel. Simple stresses – Combined stresses – Torsional and Bending stresses – Impact stresses – Stress strain relation – Various theories of failure – Factor of safety – Design for strength and rigidity – preferred numbers. The concept of stiffness in tension, bending, torsion and combined situations.

**UNIT II**

**Strength of Machine Elements:** Stress concentration – Theoretical stress Concentration factor – Fatigue stress concentration factor- Notch Sensitivity – Design for fluctuating stresses – Endurance limit – Estimation of Endurance strength – Gerber's curve, Goodman's line – Modified Goodman's line – Soderberg's line.

**UNIT III**

**Fasteners (Temporary and Permanent Joints):** Riveted joints- Methods of failure of riveted joints- strength equations-efficiency of riveted joints - eccentrically loaded riveted joints - Welded joints - Design of fillet welds-axial loads-circular fillet welds under bending, torsion- Welded joints under eccentric loading - bolted joints, Knuckle joints - Cotter joints.

**UNIT IV**

**Designs of Keys, Shaft and Shaft Couplings:** Design of solid and hollow shafts based on strength, rigidity– Keys, keyways and splines - Rigid couplings – Muff, Split muff and Flange couplings. Flexible couplings – Flange coupling (Modified).

**UNIT 5**

**Bearings: Types** of Journal bearings – Lubrication – Bearing Modulus – Full and partial bearings – Clearance ratio – Heat dissipation of bearings, bearing materials – journal bearing design – Ball and roller bearings – Static loading of ball & roller bearings, Bearing life.

**TEXT BOOKS:**

1. Machine Design by R.S Khurmi and J.K.Gupta, S.Chand Publishers, New Delhi.
2. Machine Design, S MD Jalaludin, Anuradha Publishers.
3. Design of Machine Elements by V. Bhandari TMH

**REFERENCE BOOKS:**

1. Machine Design Data Book by S MD Jalaludin, Anuradha Publisher.
2. Machine Design Data Book by P.S.G. College of Technology.
3. Machine Design by Pandya and Shah, Chortar Publications.
4. Machine Design / R.N. Norton.
5. Mechanical Engineering Design / JE Shigley.

**COURSE OUTCOMES:**

1. Student acquires the knowledge about design procedure, material selection, and influence of steady and variable stresses in machine component design.
2. Acquire the Knowledge on various stresses and theories of failures.
3. Understand the concept of joints.
4. Able to understand the design Procedure for the different Shafts and shaft couplings.
5. Able to understand suitable bearings and its constituents from manufacturers catalogues under given loading conditions

**NOTE:** Design Data Book is permitted. Design of all components should include design for strength and rigidity apart from engineering performance requirements.

## COURSE COVERAGE UNIT WISE

### UNIT I

S.NO	TOPIC NAME	NAME OF THE TEXT BOOK	AUTHOR NAME	PAGE NUMBER
1	General considerations in the design of Engineering Materials	DESIGN OF MACHINE ELEMENTS	V.V. BHANDARI	55
2	Manufacturing consideration in design	MACHINE DESIGN	R.S KHURMI	54
3	Various theories of failure	MACHINE DESIGN	R.S KHURMI	152
4	Factor of safety – Design for strength and rigidity	DESIGN OF MACHINE ELEMENTS	V.V. BHANDARI	77

### UNIT II

S.NO	TOPIC NAME	NAME OF THE TEXT BOOK	AUTHOR NAME	PAGE NUMBER
1	Stress concentration – Theoretical stress Concentration factor	DESIGN OF MACHINE ELEMENTS	V.V. BHANDARI	55
2	Design for fluctuating stresses	MACHINE DESIGN	R.S KHURMI	54
3	Gerber's curve, Goodman's line	MACHINE DESIGN	R.S KHURMI	152
4	Modified Goodman's line – Soderberg's line	DESIGN OF MACHINE ELEMENTS	V.V. BHANDARI	77

**UNIT III**

S.NO	TOPIC NAME	NAME OF THE TEXT BOOK	AUTHOR NAME	PAGE NUMBER
1	Riveted joints	MACHINE DESIGN	R.S KHURMI	281 – 340
2	Welded joints	MACHINE DESIGN	R.S KHURMI	341 – 376
3	Bolted joints	MACHINE DESIGN	R.S KHURMI	377- 430

**UNIT IV**

S.NO	TOPIC NAME	NAME OF THE TEXT BOOK	AUTHOR NAME	PAGE NUMBER
1	Design of solid and hollow shafts for strength and rigidity	Design of solid and hollow shafts for strength and rigidity	Design of solid and hollow shafts for strength and rigidity	Design of solid and hollow shafts for strength and rigidity
2	Design of shafts for combined bending and axial loads	Design of shafts for combined bending and axial loads	Design of shafts for combined bending and axial loads	Design of shafts for combined bending and axial loads
3	Rigid couplings – Muff, Split muff and Flange couplings	Rigid couplings – Muff, Split muff and Flange couplings	Rigid couplings – Muff, Split muff and Flange couplings	Rigid couplings – Muff, Split muff and Flange couplings
4	Flexible couplings – Flange coupling (Modified)	Flexible couplings – Flange coupling (Modified)	Flexible couplings – Flange coupling (Modified)	Flexible couplings – Flange coupling (Modified)

**UNIT V**

S.NO	TOPIC NAME	NAME OF THE TEXT BOOK	AUTHOR NAME	PAGE NUMBER
1	Journal bearing, Pedastal bearing, Foot step bearing	MACHINE DESIGN	R.S KHURMI	962-964

2	Lubrication Bearing Modulus Full and partial bearings	MACHINE DESIGN	R.S KHURMI	971-977
3	Clearance ratio Heat dissipation of bearings, bearing materials	MACHINE DESIGN	R.S KHURMI	981-985
4	Journal bearing design Ball and roller bearings	MACHINE DESIGN	R.S KHURMI	996-1010

# UNIT-1

## **Introduction**

The subject Machine Design is the creation of new and better machines and improving the existing ones. A new or better machine is one which is more economical in the overall cost of production and operation. The process of design is a long and time consuming one. From the study of existing ideas, a new idea has to be conceived. The idea is then studied keeping in mind its commercial success and given shape and form in the form of drawings. In the preparation of these drawings, care must be taken of the availability of resources in money, in men and in materials required for the successful completion of the new idea into an actual reality. In designing a machine component, it is necessary to have a good knowledge of many subjects such as Mathematics, Engineering Mechanics, Strength of Materials, Theory of Machines, Workshop Processes and Engineering Drawing.

## **Classifications of Machine Design**

The machine design may be classified as follows:

**1. Adaptive design.** In most cases, the designer's work is concerned with adaptation of existing designs. This type of design needs no special knowledge or skill and can be attempted by designers of ordinary technical training. The designer only makes minor alternation or modification in the existing designs of the product.

**2. Development design.** This type of design needs considerable scientific training and design ability in order to modify the existing designs into a new idea by adopting a new material or different method of manufacture. In this case, though the designer starts from the existing design, but the final product may differ quite markedly from the original product.

**3. New design.** This type of design needs lot of research, technical ability and creative thinking. Only those designers who have personal qualities of a sufficiently high order can take up the work of a new design. The designs, depending upon the methods used, may be classified as follows:

**(a) Rational design.** This type of design depends upon mathematical formulae of principle of mechanics.

**(b) Empirical design.** This type of design depends upon empirical formulae based on the practice and past experience.

**(c) Industrial design.** This type of design depends upon the production aspects to manufacture any machine component in the industry.

(d) **Optimum design.** It is the best design for the given objective function under the specified constraints. It may be achieved by minimising the undesirable effects.

(e) **System design.** It is the design of any complex mechanical system like a motor car.

(f) **Element design.** It is the design of any element of the mechanical system like piston, crankshaft, connecting rod, etc.

(g) **Computer aided design.** This type of design depends upon the use of computer systems to assist in the creation, modification, analysis and optimisation of a design.

### **General Considerations in Machine Design**

Following are the general considerations in designing a machine component:

**1. Type of load and stresses caused by the load.** The load, on a machine component, may act in several ways due to which the internal stresses are set up. The various types of load and stresses are discussed later.

**2. Motion of the parts or kinematics of the machine.** The successful operation of any machine depends largely upon the simplest arrangement of the parts which will give the motion required. The motion of the parts may be:

- (a) Rectilinear motion which includes unidirectional and reciprocating motions.
- (b) Curvilinear motion which includes rotary, oscillatory and simple harmonic.
- (c) Constant velocity.
- (d) Constant or variable acceleration.

**3. Selection of materials.** It is essential that a designer should have a thorough knowledge of the properties of the materials and their behaviour under working conditions. Some of the important characteristics of materials are: strength, durability, flexibility, weight, resistance to heat and corrosion, ability to cast, welded or hardened, machinability, electrical conductivity, etc. The various types of engineering materials and their properties are discussed later.

**4. Form and size of the parts.** The form and size are based on judgment. The smallest practicable cross-section may be used, but it may be checked that the stresses induced in the designed cross-section are reasonably safe. In order to design any machine part for form and



size, it is necessary to know the forces which the part must sustain. It is also important to anticipate any suddenly applied or impact load which may cause failure.

**5. *Frictional resistance and lubrication.*** There is always a loss of power due to frictional resistance and it should be noted that the friction of starting is higher than that of running friction. It is, therefore, essential that a careful attention must be given to the matter of lubrication of all surfaces which move in contact with others, whether in rotating, sliding, or rolling bearings.

**6. *Convenient and economical features.*** In designing, the operating features of the machine should be carefully studied. The starting, controlling and stopping levers should be located on the basis of convenient handling. The adjustment for wear must be provided employing the various take up devices and arranging them so that the alignment of parts is preserved. If parts are to be changed for different products or replaced on account of wear or breakage, easy access should be provided and the necessity of removing other parts to accomplish this should be avoided if possible. The economical operation of a machine which is to be used for production or for the processing of material should be studied, in order to learn whether it has the maximum capacity consistent with the production of good work.

**7. *Use of standard parts.*** The use of standard parts is closely related to cost, because the cost of standard or stock parts is only a fraction of the cost of similar parts made to order. The standard or stock parts should be used whenever possible; parts for which patterns are already in existence such as gears, pulleys and bearings and parts which may be selected from regular shop stock such as screws, nuts and pins. Bolts and studs should be as few as possible to avoid the delay caused by changing drills, reamers and taps and also to decrease the number of wrenches required.

**8. *Safety of operation.*** Some machines are dangerous to operate, especially those which are speeded up to insure production at a maximum rate. Therefore, any moving part of a machine which is within the zone of a worker is considered an accident hazard and may be the cause of an injury. It is, therefore, necessary that a designer should always provide safety devices for the safety of the operator. The safety appliances should in no way interfere with operation of the machine.

**9. Workshop facilities.** A design engineer should be familiar with the limitations of this employer's workshop, in order to avoid the necessity of having work done in some other workshop. It is sometimes necessary to plan and supervise the workshop operations and to draft methods for casting, handling and machining special parts.

**10. Number of machines to be manufactured.** The number of articles or machines to be manufactured affects the design in a number of ways. The engineering and shop costs which are called fixed charges or overhead expenses are distributed over the number of articles to be manufactured. If only a few articles are to be made, extra expenses are not justified unless the machine is large or of some special design. An order calling for small number of the product will not permit any undue expense in the workshop processes, so that the designer should restrict his specification to standard parts as much as possible.

**11. Cost of construction.** The cost of construction of an article is the most important consideration involved in design. In some cases, it is quite possible that the high cost of an article may immediately bar it from further considerations. If an article has been invented and tests of handmade samples have shown that it has commercial value, it is then possible to justify the expenditure of a considerable sum of money in the design and development of automatic machines to produce the article, especially if it can be sold in large numbers. The aim of design engineer under all conditions should be to reduce the manufacturing cost to the minimum.

**12. Assembling.** Every machine or structure must be assembled as a unit before it can function. Large units must often be assembled in the shop, tested and then taken to be transported to their place of service. The final location of any machine is important and the design engineer must anticipate the exact location and the local facilities for erection.

### **General Procedure in Machine Design**

In designing a machine component, there is no rigid rule. The problem may be attempted in several ways. However, the general procedure to solve a design problem is as follows:

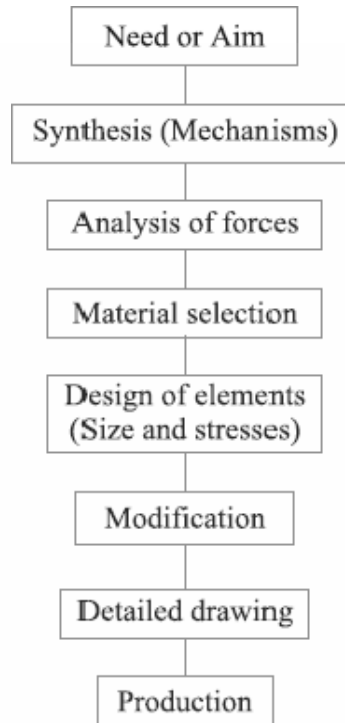

Fig.1. General Machine Design Procedure

**1. Recognition of need.** First of all, make a complete statement of the problem, indicating the need, aim or purpose for which the machine is to be designed.

**2. Synthesis (Mechanisms).** Select the possible mechanism or group of mechanisms which will give the desired motion.

**3. Analysis of forces.** Find the forces acting on each member of the machine and the energy transmitted by each member.

**4. Material selection.** Select the material best suited for each member of the machine.

**5. Design of elements (Size and Stresses).** Find the size of each member of the machine by considering the force acting on the member and the permissible stresses for the material used. It should be kept in mind that each member should not deflect or deform than the permissible limit.

**6. Modification.** Modify the size of the member to agree with the past experience and judgment to facilitate manufacture. The modification may also be necessary by consideration of manufacturing to reduce overall cost.

**7. Detailed drawing.** Draw the detailed drawing of each component and the assembly of the machine with complete specification for the manufacturing processes suggested.

**8. Production.** The component, as per the drawing, is manufactured in the workshop.

The flow chart for the general procedure in machine design is shown in Fig.

**Note:** When there are number of components in the market having the same qualities of efficiency, durability and cost, then the customer will naturally attract towards the most appealing product. The aesthetic and ergonomics are very important features which gives grace and lustre to product and dominates the market.

### **Engineering materials and their properties**

The knowledge of materials and their properties is of great significance for a design engineer. The machine elements should be made of such a material which has properties suitable for the conditions of operation. In addition to this, a design engineer must be familiar with the effects which the manufacturing processes and heat treatment have on the properties of the materials. Now, we shall discuss the commonly used engineering materials and their properties in Machine Design.

### **Classification of Engineering Materials**

The engineering materials are mainly classified as:

1. Metals and their alloys, such as iron, steel, copper, aluminum, etc.
2. Non-metals, such as glass, rubber, plastic, etc.

The metals may be further classified as:

- (a) Ferrous metals and (b) Non-ferrous metals.

The *\*ferrous metals* are those which have the iron as their main constituent, such as cast iron, wrought iron and steel.

The *non-ferrous* metals are those which have a metal other than iron as their main constituent, such as copper, aluminum, brass, tin, zinc, etc.

### **Selection of Materials for Engineering Purposes**

The selection of a proper material, for engineering purposes, is one of the most difficult problems for the designer. The best material is one which serves the desired objective at the minimum cost.

The following factors should be considered while selecting the material:

1. Availability of the materials,
2. Suitability of the materials for the working conditions in service, and
3. The cost of the materials.

The important properties, which determine the utility of the material, are physical, chemical and mechanical properties. We shall now discuss the physical and mechanical properties of the material in the following articles.

### **Physical Properties of Metals**

The physical properties of the metals include luster, colour, size and shape, density, electric and thermal conductivity, and melting point. The following table shows the important physical properties of some pure metals.

### **Mechanical Properties of Metals**

The mechanical properties of the metals are those which are associated with the ability of the material to resist mechanical forces and load. These mechanical properties of the metal include strength, stiffness, elasticity, plasticity, ductility, brittleness, malleability, toughness, resilience, creep and hardness. We shall now discuss these properties as follows:

1. **Strength.** It is the ability of a material to resist the externally applied forces without breaking or yielding. The internal resistance offered by a part to an externally applied force is called stress.
2. **Stiffness.** It is the ability of a material to resist deformation under stress. The modulus of elasticity is the measure of stiffness.

**3. Elasticity.** It is the property of a material to regain its original shape after deformation when the external forces are removed. This property is desirable for materials used in tools and machines. It may be noted that steel is more elastic than rubber.

**4. Plasticity.** It is property of a material which retains the deformation produced under load permanently. This property of the material is necessary for forgings, in stamping images on coins and in ornamental work.

**5. Ductility.** It is the property of a material enabling it to be drawn into wire with the application of a tensile force. A ductile material must be both strong and plastic. The ductility is usually measured by the terms, percentage elongation and percentage reduction in area. The ductile material commonly used in engineering practice (in order of diminishing ductility) are mild steel, copper, aluminium, nickel, zinc, tin and lead.

**6. Brittleness.** It is the property of a material opposite to ductility. It is the property of breaking of a material with little permanent distortion. Brittle materials when subjected to tensile loads snap off without giving any sensible elongation. Cast iron is a brittle material.

**7. Malleability.** It is a special case of ductility which permits materials to be rolled or hammered into thin sheets. A malleable material should be plastic but it is not essential to be so strong. The malleable materials commonly used in engineering practice (in order of diminishing malleability) are lead, soft steel, wrought iron, copper and aluminium.

**8. Toughness.** It is the property of a material to resist fracture due to high impact loads like hammer blows. The toughness of the material decreases when it is heated. It is measured by the amount of energy that a unit volume of the material has absorbed after being stressed upto the point of fracture. This property is desirable in parts subjected to shock and impact loads.

**9. Machinability.** It is the property of a material which refers to a relative ease with which a material can be cut. The machinability of a material can be measured in a number of ways such as comparing the tool life for cutting different materials or thrust required to remove the material at some given rate or the energy required to remove a unit volume of the material. It may be noted that brass can be easily machined than steel.

**10. Resilience.** It is the property of a material to absorb energy and to resist shock and impact loads. It is measured by the amount of energy absorbed per unit volume within elastic limit. This property is essential for spring materials.

**11. Creep.** When a part is subjected to a constant stress at high temperature for a long period of time, it will undergo a slow and permanent deformation called **creep**. This property is considered in designing internal combustion engines, boilers and turbines.

**12. Fatigue.** When a material is subjected to repeated stresses, it fails at stresses below the yield point stresses. Such type of failure of a material is known as **\*fatigue**. The failure is caused by means of a progressive crack formation which are usually fine and of microscopic size. This property is considered in designing shafts, connecting rods, springs, gears, etc.

**13. Hardness.** It is a very important property of the metals and has a wide variety of meanings. It embraces many different properties such as resistance to wear, scratching, deformation and machinability etc. It also means the ability of a metal to cut another metal. The hardness is usually expressed in numbers which are dependent on the method of making the test. The hardness of a metal may be determined by the following tests:

- (a) Brinell hardness test,
- (b) Rockwell hardness test,
- (c) Vickers hardness (also called Diamond Pyramid) test, and
- (d) Shore scleroscope.

### **Steel**

It is an alloy of iron and carbon, with carbon content up to a maximum of 1.5%. The carbon occurs in the form of iron carbide, because of its ability to increase the hardness and strength of the steel. Other elements *e.g.* silicon, sulphur, phosphorus and manganese are also present to greater or lesser amount to impart certain desired properties to it. Most of the steel produced now-a-days is **plain carbon steel** or simply **carbon steel**. A carbon steel is defined as a steel which has its properties mainly due to its carbon content and does not contain more than 0.5% of silicon and 1.5% of manganese.

The plain carbon steels varying from 0.06% carbon to 1.5% carbon are divided into the following types depending upon the carbon content.

1. Dead mild steel — up to 0.15% carbon

2. Low carbon or mild steel — 0.15% to 0.45% carbon

3. Medium carbon steel — 0.45% to 0.8% carbon

4. High carbon steel — 0.8% to 1.5% carbon

According to Indian standard \*[IS: 1762 (Part-I)–1974], a new system of designating the steel is recommended. According to this standard, steels are designated on the following two basis:

(a) On the basis of mechanical properties, and (b) On the basis of chemical composition. We shall now discuss, in detail, the designation of steel on the above two basis, in the following pages.

### **Steels Designated on the Basis of Mechanical Properties**

These steels are carbon and low alloy steels where the main criterion in the selection and inspection of steel is the tensile strength or yield stress. According to Indian standard IS: 1570 (Part-I)- 1978 (Reaffirmed 1993), these steels are designated by a symbol 'Fe' or 'Fe E' depending on whether the steel has been specified on the basis of minimum tensile strength or yield strength, followed by the figure indicating the minimum tensile strength or yield stress in N/mm<sup>2</sup>. For example 'Fe 290' means a steel having minimum tensile strength of 290 N/mm<sup>2</sup> and 'Fe E 220' means a steel having yield strength of 220 N/mm<sup>2</sup>.

### **Steels Designated on the Basis of Chemical Composition**

According to Indian standard, IS : 1570 (Part II/Sec I)-1979 (Reaffirmed 1991), the carbon steels are designated in the following order :

(a) Figure indicating 100 times the average percentage of carbon content,

(b) Letter 'C', and

(c) Figure indicating 10 times the average percentage of manganese content. The figure after multiplying shall be rounded off to the nearest integer.

For example 20C8 means a carbon steel containing 0.15 to 0.25 per cent (0.2 per cent on average) carbon and 0.60 to 0.90 per cent (0.75 per cent rounded off to 0.8 per cent on an average) manganese.

### **Effect of Impurities on Steel**

The following are the effects of impurities like silicon, sulphur, manganese and phosphorus on steel.



1. **Silicon.** The amount of silicon in the finished steel usually ranges from 0.05 to 0.30%. Silicon is added in low carbon steels to prevent them from becoming porous. It removes the gases and oxides, prevent blow holes and thereby makes the steel tougher and harder.

2. **Sulphur.** It occurs in steel either as iron sulphide or manganese sulphide. Iron sulphide because of its low melting point produces red shortness, whereas manganese sulphide does not affect so much. Therefore, manganese sulphide is less objectionable in steel than iron sulphide.

3. **Manganese.** It serves as a valuable deoxidising and purifying agent in steel. Manganese also combines with sulphur and thereby decreases the harmful effect of this element remaining in the steel. When used in ordinary low carbon steels, manganese makes the metal ductile and of good bending qualities. In high speed steels, it is used to toughen the metal and to increase its critical temperature.

4. **Phosphorus.** It makes the steel brittle. It also produces cold shortness in steel. In low carbon steels, it raises the yield point and improves the resistance to atmospheric corrosion. The sum of carbon and phosphorus usually does not exceed 0.25%.

**References:**

1. Machine Design - V.Bandari .
2. Machine Design – R.S. Khurmi
3. Design Data hand Book - S MD Jalaludin.

## **Manufacturing considerations in Machine design**

### **Manufacturing Processes**

The knowledge of manufacturing processes is of great importance for a design engineer. The following are the various manufacturing processes used in Mechanical Engineering.

**1. Primary shaping processes.** The processes used for the preliminary shaping of the machine component are known as primary shaping processes. The common operations used for this process are casting, forging, extruding, rolling, drawing, bending, shearing, spinning, powder metal forming, squeezing, etc.

**2. Machining processes.** The processes used for giving final shape to the machine component, according to planned dimensions are known as machining processes. The common operations used for this process are turning, planning, shaping, drilling, boring, reaming, sawing, broaching, milling, grinding, hobbing, etc.

**3. Surface finishing processes.** The processes used to provide a good surface finish for the machine component are known as surface finishing processes. The common operations used for this process are polishing, buffing, honing, lapping, abrasive belt grinding, barrel tumbling, electroplating, super finishing, sheradizing, etc.

**4. Joining processes.** The processes used for joining machine components are known as joining processes. The common operations used for this process are welding, riveting, soldering, brazing, screw fastening, pressing, sintering, etc.

**5. Processes effecting change in properties.** These processes are used to impart certain specific properties to the machine components so as to make them suitable for particular operations or uses. Such processes are heat treatment, hot-working, cold-working and shot peening.

### **Other considerations in Machine design**

1. Workshop facilities.
2. Number of machines to be manufactured
3. Cost of construction

## Stress

When some external system of forces or loads acts on a body, the internal forces (equal and opposite) are set up at various sections of the body, which resist the external forces. This internal force per unit area at any section of the body is known as **unit stress** or simply a **stress**. It is denoted by a Greek letter sigma ( $\sigma$ ). Mathematically,

$$\text{Stress, } \sigma = P/A$$

Where  $P$  = Force or load acting on a body, and

$A$  = Cross-sectional area of the body.

In S.I. units, the stress is usually expressed in Pascal (Pa) such that  $1 \text{ Pa} = 1 \text{ N/m}^2$ . In actual practice, we use bigger units of stress *i.e.* megapascal (MPa) and gigapascal (GPa), such that

$$1 \text{ MPa} = 1 \times 10^6 \text{ N/m}^2 = 1 \text{ N/mm}^2$$

And  $1 \text{ GPa} = 1 \times 10^9 \text{ N/m}^2 = 1 \text{ kN/mm}^2$

## Strain

When a system of forces or loads act on a body, it undergoes some deformation. This deformation per unit length is known as **unit strain** or simply a **strain**. It is denoted by a Greek letter epsilon ( $\epsilon$ ). Mathematically,

$$\text{Strain, } \epsilon = \delta l / l \quad \text{or } \delta l = \epsilon.l$$

Where  $\delta l$  = Change in length of the body, and

$l$  = Original length of the body.

## Tensile Stress and Strain

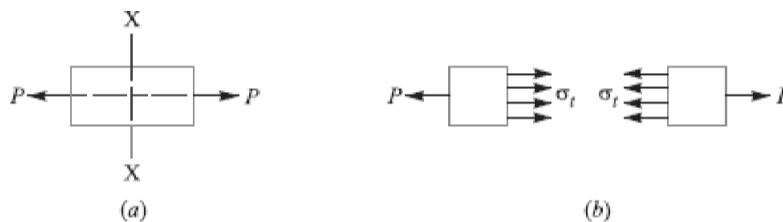

Fig. Tensile stress and strain

When a body is subjected to two equal and opposite axial pulls  $P$  (also called tensile load) as shown in Fig. (a), then the stress induced at any section of the body is known as **tensile stress**

as shown in Fig. (b). A little consideration will show that due to the tensile load, there will be a decrease in cross-sectional area and an increase in length of the body. The ratio of the increase in length to the original length is known as **tensile strain**.

Let  $P$  = Axial tensile force acting on the body,

$A$  = Cross-sectional area of the body,

$l$  = Original length, and

$\delta l$  = Increase in length.

Then  $\square$  Tensile stress,  $\sigma_t = P/A$

and tensile strain,  $\epsilon_t = \delta l / l$

### Young's Modulus or Modulus of Elasticity

**Hooke's law\*** states that when a material is loaded within elastic limit, the stress is directly proportional to strain, *i.e.*

$$\sigma \propto \epsilon \quad \text{or} \quad \sigma = E.\epsilon$$

$$E = \frac{\sigma}{\epsilon} = \frac{P \times l}{A \times \delta l}$$

where  $E$  is a constant of proportionality known as **Young's modulus** or **modulus of elasticity**. In S.I. units, it is usually expressed in GPa *i.e.* GN/m<sup>2</sup> or kN/mm<sup>2</sup>. It may be noted that Hooke's law holds good for tension as well as compression.

The following table shows the values of modulus of elasticity or Young's modulus ( $E$ ) for the materials commonly used in engineering practice.

Values of  $E$  for the commonly used engineering materials.

<i>Material</i>	<i>Modulus of elasticity (E) in GPa i.e. GN/m<sup>2</sup> for kN/mm<sup>2</sup></i>
Steel and Nickel	200 to 220
Wrought iron	190 to 200
Cast iron	100 to 160
Copper	90 to 110
Brass	80 to 90
Aluminium	60 to 80
Timber	10

## Shear Stress and Strain

When a body is subjected to two equal and opposite forces acting tangentially across the resisting section, as a result of which the body tends to shear off the section, then the stress induced is called *shear stress*.

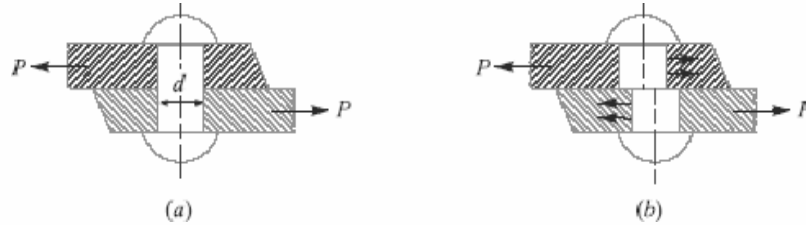

Fig. Single shearing of a riveted joint.

The corresponding strain is known as *shear strain* and it is measured by the angular deformation accompanying the shear stress. The shear stress and shear strain are denoted by the Greek letters tau ( $\tau$ ) and phi ( $\phi$ ) respectively. Mathematically,

$$\text{Shear stress, } \tau = \frac{\text{Tangential force}}{\text{Resisting area}}$$

Consider a body consisting of two plates connected by a rivet as shown in Fig. (a). In this case, the tangential force  $P$  tends to shear off the rivet at one cross-section as shown in Fig.

(b). It may be noted that when the tangential force is resisted by one cross-section of the rivet (or when shearing takes place at one cross-section of the rivet), then the rivets are said to be in *single shear*. In such a case, the area resisting the shear off the rivet,

$$A = \frac{\pi}{4} \times d^2$$

And shear stress on the rivet cross-section

$$\tau = \frac{P}{A} = \frac{P}{\frac{\pi}{4} \times d^2} = \frac{4P}{\pi d^2}$$

Now let us consider two plates connected by the two cover plates as shown in Fig. (a). In this case, the tangential force  $P$  tends to shear off the rivet at two cross-sections as shown in Fig.

(b). It may be noted that when the tangential force is resisted by two cross-sections of the

rivet (or when the shearing takes place at Two cross-sections of the rivet), then the rivets are said to be in *double shear*. In such a case, the area resisting the shear off the rivet,

$$A = 2 \times \frac{\pi}{4} \times d^2 \quad (\text{For double shear})$$

and shear stress on the rivet cross-section.

$$\tau = \frac{P}{A} = \frac{P}{2 \times \frac{\pi}{4} \times d^2} = \frac{2P}{\pi d^2}$$

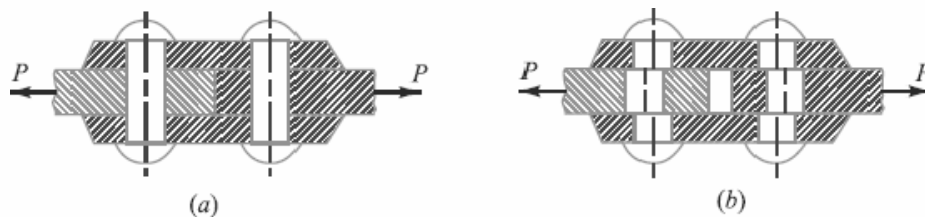

Fig. Double shearing of a riveted joint.

**Notes:**

1. All lap joints and single cover butt joints are in single shear, while the butt joints with double cover plates are in double shear.
2. In case of shear, the area involved is parallel to the external force applied.
3. When the holes are to be punched or drilled in the metal plates, then the tools used to perform the operations must overcome the ultimate shearing resistance of the material to be cut. If a hole of diameter 'd' is to be punched in a metal plate of thickness 't', then the area to be sheared,

$$A = \pi d \times t$$

And the maximum shear resistance of the tool or the force required to punch a hole,

Where  $\sigma_u$  = Ultimate shear strength of the material of the plate.  $P = d \times \tau = \pi d \times t \times \tau$

**Shear Modulus or Modulus of Rigidity**

It has been found experimentally that within the elastic limit, the shear stress is directly proportional to shear strain. Mathematically

$$\tau \propto \phi \quad \text{or} \quad \tau = C \cdot \phi \quad \text{or} \quad \tau / \phi = C$$

Where  $\tau$  = Shear stress,

$\phi$  = Shear strain, and

$C$  = Constant of proportionality, known as shear modulus or modulus of rigidity. It is also denoted by  $N$  or  $G$ .

The following table shows the values of modulus of rigidity ( $C$ ) for the materials in every day use:

Values of  $C$  for the commonly used materials

Material	Modulus of rigidity ( $C$ ) in GPa i.e. $\text{GN/m}^2$ or $\text{kNmm}^2$
Steel	80 to 100
Wrought iron	80 to 90
Cast iron	40 to 50
Copper	30 to 50
Brass	30 to 50
Timber	10

### Linear and Lateral Strain

Consider a circular bar of diameter  $d$  and length  $l$ , subjected to a tensile force  $P$  as shown in Fig. (a).

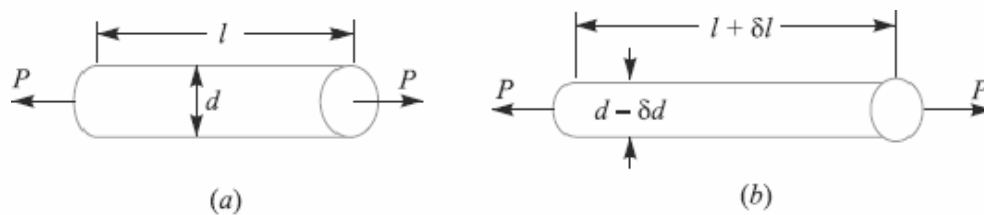

Fig. Linear and lateral strain.

A little consideration will show that due to tensile force, the length of the bar increases by an amount  $\delta l$  and the diameter decreases by an amount  $\delta d$ , as shown in Fig. (b). Similarly, if the bar is subjected to a compressive force, the length of bar will decrease which will be followed by increase in diameter.

It is thus obvious, that every direct stress is accompanied by a strain in its own direction which is known as **linear strain** and an opposite kind of strain in every direction, at right angles to it, is known as **lateral strain**.

#### 4.18 Poisson's Ratio

It has been found experimentally that when a body is stressed within elastic limit, the lateral strain bears a constant ratio to the linear strain, Mathematically,

$$\frac{\text{Lateral Strain}}{\text{Linear Strain}} = \text{Constant}$$

This constant is known as **Poisson's ratio** and is denoted by  $1/m$  or  $\mu$ .

Following are the values of Poisson's ratio for some of the materials commonly used in engineering practice.

Values of Poisson's ratio for commonly used materials

S.No.	Material	Poisson 's ratio ( $1/m$ or $\mu$ )
1	Steel	0.25 to 0.33
2	Cast iron	0.23 to 0.27
3	Copper	0.31 to 0.34
4	Brass	0.32 to 0.42
5	Aluminium	0.32 to 0.36
6	Concrete	0.08 to 0.18
7	Rubber	0.45 to 0.50

#### Volumetric Strain

When a body is subjected to a system of forces, it undergoes some changes in its dimensions. In other words, the volume of the body is changed. The ratio of the change in volume to the original volume is known as **volumetric strain**. Mathematically, volumetric strain,

$$\epsilon_v = \delta V / V$$

Where  $\delta V$  = Change in volume, and  $V$  = Original volume

**Notes : 1.** Volumetric strain of a rectangular body subjected to an axial force is given as

$$\epsilon_v = \frac{\delta V}{V} = \epsilon \left( 1 - \frac{2}{m} \right); \text{ where } \epsilon = \text{Linear strain.}$$

**2.** Volumetric strain of a rectangular body subjected to three mutually perpendicular forces is given by



$$\epsilon_v = \epsilon_x + \epsilon_y + \epsilon_z$$

where  $\epsilon_x$ ,  $\epsilon_y$  and  $\epsilon_z$  are the strains in the directions  $x$ -axis,  $y$ -axis and  $z$ -axis respectively.

### **Bulk Modulus**

When a body is subjected to three mutually perpendicular stresses, of equal intensity, then the ratio of the direct stress to the corresponding volumetric strain is known as **bulk modulus**. It is usually denoted by  $K$ . Mathematically, bulk modulus,

$$K = \frac{\text{Direct stress}}{\text{Volumetric strain}} = \frac{\sigma}{\delta V/V}$$

### **Relation Between Bulk Modulus and Young's Modulus**

The bulk modulus ( $K$ ) and Young's modulus ( $E$ ) are related by the following relation,

$$K = \frac{m.E}{3(m-2)} = \frac{E}{3(1-2\mu)}$$

### **Relation between Young's Modulus and Modulus of Rigidity**

The Young's modulus ( $E$ ) and modulus of rigidity ( $G$ ) are related by the following relation,

$$G = \frac{m.E}{2(m+1)} = \frac{E}{2(1+\mu)}$$

### **Factor of Safety**

It is defined, in general, as the **ratio of the maximum stress to the working stress**.

Mathematically,

$$\text{Factor of safety} = \text{Maximum stress} / \text{Working or design stress}$$

In case of ductile materials *e.g.* mild steel, where the yield point is clearly defined, the factor of safety is based upon the yield point stress. In such cases,

$$\text{Factor of safety} = \text{Yield point stress} / \text{Working or design stress}$$

In case of brittle materials *e.g.* cast iron, the yield point is not well defined as for ductile materials. Therefore, the factor of safety for brittle materials is based on ultimate stress.

$$\text{Factor of safety} = \text{Ultimate stress} / \text{Working or design stress}$$

This relation may also be used for ductile materials.

The above relations for factor of safety are for static loading.

**Problem:**

A steel bar 2.4 m long and 30 mm square is elongated by a load of 500 kN. If poisson's ratio is 0.25, find the increase in volume. Take  $E = 0.2 \times 10^6 \text{ N/mm}^2$ .

**Solution.** Given :  $l = 2.4 \text{ m} = 2400 \text{ mm}$  ;  $A = 30 \times 30 = 900 \text{ mm}^2$  ;  $P = 500 \text{ kN} = 500 \times 10^3 \text{ N}$  ;  
 $l/m = 0.25$  ;  $E = 0.2 \times 10^6 \text{ N/mm}^2$

Let  $\delta V = \text{Increase in volume.}$

We know that volume of the rod,

$$V = \text{Area} \times \text{length} = 900 \times 2400 = 2160 \times 10^3 \text{ mm}^3$$

and Young's modulus,  $E = \frac{\text{Stress}}{\text{Strain}} = \frac{P/A}{\epsilon}$

$$\therefore \epsilon = \frac{P}{A.E} = \frac{500 \times 10^3}{900 \times 0.2 \times 10^6} = 2.8 \times 10^{-3}$$

We know that volumetric strain,

$$\frac{\delta V}{V} = \epsilon \left( 1 - \frac{2}{m} \right) = 2.8 \times 10^{-3} (1 - 2 \times 0.25) = 1.4 \times 10^{-3}$$

$$\therefore \delta V = V \times 1.4 \times 10^{-3} = 2160 \times 10^3 \times 1.4 \times 10^{-3} = 3024 \text{ mm}^3 \text{ Ans.}$$

**References:**

1. Machine Design - V.Bandari .
2. Machine Design – R.S. Khurmi
3. Design Data hand Book - S MD Jalaludin.

## Impact Stress

Sometimes, machine members are subjected to the load with impact. The stress produced in the member due to the falling load is known as **impact stress**. Consider a bar carrying a load  $W$  at a height  $h$  and falling on the collar provided at the lower end, as shown in Fig.

Let  $A$  = Cross-sectional area of the bar,

$E$  = Young's modulus of the material of the bar,

$l$  = Length of the bar,

$\delta l$  = Deformation of the bar,

$P$  = Force at which the deflection  $\delta l$  is produced,

$\sigma_i$  = Stress induced in the bar due to the application of impact load, and

$h$  = Height through which the load falls.

We know that energy gained by the system in the form of strain energy

$$= \frac{1}{2} \times P \times \delta l$$

And potential energy lost by the weight

$$= W(h + \delta l)$$

Since the energy gained by the system is equal to the potential energy lost by the weight, therefore

$$\frac{1}{2} \times P \times \delta l = W(h + \delta l)$$

$$\frac{1}{2} \sigma_i \times A \times \frac{\sigma_i \times l}{E} = W \left( h + \frac{\sigma_i \times l}{E} \right) \quad \dots \left[ \because P = \sigma_i \times A, \text{ and } \delta l = \frac{\sigma_i \times l}{E} \right]$$

From this quadratic equation, we find that

$$\sigma_i = \frac{W}{A} \left( 1 + \sqrt{1 + \frac{2hAE}{Wl}} \right) \quad \dots \text{ [Taking +ve sign for maximum value]}$$

When  $h = 0$ , then  $\sigma_i = 2W/A$ . This means that the stress in the bar when the load is applied suddenly is double of the stress induced due to gradually applied load.

Problem:

An unknown weight falls through 10 mm on a collar rigidly attached to the lower end of a vertical bar 3 m long and 600 mm<sup>2</sup> in section. If the maximum instantaneous extension is known to be 2 mm, what is the corresponding stress and the value of unknown weight? Take  $E = 200 \text{ kN/mm}^2$ .

**Solution. Given :**  $h = 10 \text{ mm}$  ;  $l = 3 \text{ m} = 3000 \text{ mm}$  ;  $A = 600 \text{ mm}^2$  ;  $\delta l = 2 \text{ mm}$  ;  
 $E = 200 \text{ kN/mm}^2 = 200 \times 10^3 \text{ N/mm}^2$

*Stress in the bar*

Let  $\sigma = \text{Stress in the bar.}$

We know that Young's modulus,

$$E = \frac{\text{Stress}}{\text{Strain}} = \frac{\sigma}{\epsilon} = \frac{\sigma \cdot l}{\delta l}$$

$$\therefore \sigma = \frac{E \cdot \delta l}{l} = \frac{200 \times 10^3 \times 2}{3000} = \frac{400}{3} = 133.3 \text{ N/mm}^2 \text{ Ans.}$$

*Value of the unknown weight*

Let  $W = \text{Value of the unknown weight.}$

We know that 
$$\sigma = \frac{W}{A} \left[ 1 + \sqrt{1 + \frac{2hAE}{Wl}} \right]$$

$$\frac{400}{3} = \frac{W}{600} \left[ 1 + \sqrt{1 + \frac{2 \times 10 \times 600 \times 200 \times 10^3}{W \times 3000}} \right]$$

$$\frac{400 \times 600}{3W} = 1 + \sqrt{1 + \frac{800\,000}{W}}$$

$$\frac{80\,000}{W} - 1 = \sqrt{1 + \frac{800\,000}{W}}$$

Squaring both sides,

$$\frac{6400 \times 10^6}{W^2} + 1 - \frac{160\,000}{W} = 1 + \frac{800\,000}{W}$$

$$\frac{6400 \times 10^2}{W} - 16 = 80 \text{ or } \frac{6400 \times 10^2}{W} = 96$$

$$\therefore W = 6400 \times 10^2 / 96 = 6666.7 \text{ N Ans.}$$

### **Resilience**

When a body is loaded within elastic limit, it changes its dimensions and on the removal of the load, it regains its original dimensions. So long as it remains loaded, it has stored energy in itself. On removing the load, the energy stored is given off as in the case of a spring. This energy, which is absorbed in a body when strained within elastic limit, is known as **strain energy**.

The strain energy is always capable of doing some work.

The strain energy stored in a body due to external loading, within elastic limit, is known as **resilience** and the maximum energy which can be stored in a body up to the elastic limit is called **proof resilience**. The proof resilience per unit volume of a material is known as

**modulus of resilience.** It is an important property of a material and gives capacity of the material to bear impact or shocks. Mathematically, strain energy stored in a body due to tensile or compressive load or resilience,

$$U = \frac{\sigma^2 \times V}{2E}$$

And Modulus of resilience

$$= \frac{\sigma^2}{2E}$$

Where  $\sigma$  = Tensile or compressive stress,

$V$  = Volume of the body, and

$E$  = Young's modulus of the material of the body.

When a body is subjected to a shear load, then modulus of resilience (shear)

$$= \frac{\tau^2}{2C}$$

Where  $\tau$  = Shear stress, and

$C$  = Modulus of rigidity.

When the body is subjected to torsion, then modulus of resilience

$$= \frac{\tau^2}{4C}$$

Problem:

A wrought iron bar 50 mm in diameter and 2.5 m long transmits shock energy of 100 N-m.

Find the maximum instantaneous stress and the elongation. Take  $E = 200 \text{ GN/m}^2$ .

**Solution.** Given :  $d = 50 \text{ mm}$  ;  $l = 2.5 \text{ m} = 2500 \text{ mm}$  ;  $U = 100 \text{ N-m} = 100 \times 10^3 \text{ N-mm}$  ;  
 $E = 200 \text{ GN/m}^2 = 200 \times 10^3 \text{ N/mm}^2$

**Maximum instantaneous stress**

Let  $\sigma$  = Maximum instantaneous stress.

We know that volume of the bar,

$$V = \frac{\pi}{4} \times d^2 \times l = \frac{\pi}{4} (50)^2 \times 2500 = 4.9 \times 10^6 \text{ mm}^3$$

We also know that shock or strain energy stored in the body ( $U$ ),

$$100 \times 10^3 = \frac{\sigma^2 \times V}{2E} = \frac{\sigma^2 \times 4.9 \times 10^6}{2 \times 200 \times 10^3} = 12.25 \sigma^2$$

$$\therefore \sigma^2 = 100 \times 10^3 / 12.25 = 8163 \text{ or } \sigma = 90.3 \text{ N/mm}^2 \text{ Ans.}$$

*Elongation produced*

Let

 $\delta l =$  Elongation produced.

We know that Young's modulus,

$$E = \frac{\text{Stress}}{\text{Strain}} = \frac{\sigma}{\epsilon} = \frac{\sigma}{\delta l / l}$$

 $\therefore$ 

$$\delta l = \frac{\sigma \times l}{E} = \frac{90.3 \times 2500}{200 \times 10^3} = 1.13 \text{ mm Ans.}$$

**References:**

1. Machine Design - V.Bandari .
2. Machine Design – R.S. Khurmi
3. Design Data hand Book - S MD Jalaludin.

### Torsional Shear Stress

When a machine member is subjected to the action of two equal and opposite couples acting in parallel planes (or torque or twisting moment), then the machine member is said to be subjected to **torsion**. The stress set up by torsion is known as **torsional shear stress**. It is zero at the centroidal axis and maximum at the outer surface. Consider a shaft fixed at one end and subjected to a torque ( $T$ ) at the other end as shown in Fig. As a result of this torque, every cross-section of the shaft is subjected to torsional shear stress. We have discussed above that the torsional shear stress is zero at the centroidal axis and maximum at the outer surface. The maximum torsional shear stress at the outer surface of the shaft may be obtained from the following equation:

$$\tau = \frac{T}{J} = \frac{C \cdot \theta}{l} \quad (i)$$

Where  $\tau$  = Torsional shear stress induced at the outer surface of the shaft or maximum shear stress,

$r$  = Radius of the shaft,

$T$  = Torque or twisting moment,

$J$  = Second moment of area of the section about its polar axis or polar moment of inertia,

$C$  = Modulus of rigidity for the shaft material,

$l$  = Length of the shaft, and

$\theta$  = Angle of twist in radians on a length  $l$ .

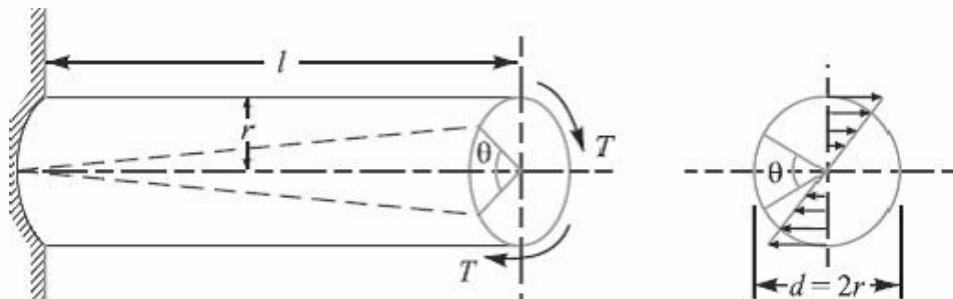

The above equation is known as **torsion equation**. It is based on the following assumptions:

1. The material of the shaft is uniform throughout.
2. The twist along the length of the shaft is uniform.
3. The normal cross-sections of the shaft, which were plane and circular before twist, remain plane and circular after twist.

4. All diameters of the normal cross-section which were straight before twist, remain straight with their magnitude unchanged, after twist.

5. The maximum shear stress induced in the shaft due to the twisting moment does not exceed its elastic limit value.

**Note: 1.** Since the torsional shear stress on any cross-section normal to the axis is directly proportional to the distance from the centre of the axis, therefore the torsional shear stress at a distance  $x$  from the centre of the shaft is given by

$$\frac{\tau_x}{x} = \frac{\tau}{r}$$

2. From equation (i), we know that

$$\frac{T}{J} = \frac{\tau}{r} \quad \text{or} \quad T = \tau \times \frac{J}{r}$$

For a solid shaft of diameter ( $d$ ), the polar moment of inertia,

$$J = I_{XX} + I_{YY} = \frac{\pi}{64} \times d^4 + \frac{\pi}{64} \times d^4 = \frac{\pi}{32} \times d^4$$

Therefore,

$$T = \tau \times \frac{\pi}{32} \times d^4 \times \frac{2}{d} = \frac{\pi}{16} \times \tau \times d^3$$

In case of a hollow shaft with external diameter ( $d_o$ ) and internal diameter ( $d_i$ ), the polar moment of inertia,

$$J = \frac{\pi}{32} [(d_o)^4 - (d_i)^4] \text{ and } r = \frac{d_o}{2}$$

$$T = \tau \times \frac{\pi}{32} [(d_o)^4 - (d_i)^4] \times \frac{2}{d_o} = \frac{\pi}{16} \times \tau \left[ \frac{(d_o)^4 - (d_i)^4}{d_o} \right]$$

$$= \frac{\pi}{16} \times \tau (d_o)^3 (1 - k^4) \quad \dots \left( \text{Substituting, } k = \frac{d_i}{d_o} \right)$$

3. The expression ( $C \times J$ ) is called **torsional rigidity** of the shaft.

4. The strength of the shaft means the maximum torque transmitted by it. Therefore, in order to design a shaft for strength, the above equations are used. The power transmitted by the shaft (in watts) is given by

$$P = \frac{2 \pi N \cdot T}{60} = T \cdot \omega \quad \dots \left( \because \omega = \frac{2 \pi N}{60} \right)$$



Where  $T$  = Torque transmitted in N-m, and

$\omega$  = Angular speed in rad/s.

Problem:

A shaft is transmitting 100 kW at 160 r.p.m. Find a suitable diameter for the shaft, if the maximum torque transmitted exceeds the mean by 25%. Take maximum allowable shear stress as 70 MPa.

**Solution.** Given :  $P = 100 \text{ kW} = 100 \times 10^3 \text{ W}$  ;  $N = 160 \text{ r.p.m}$  ;  $T_{max} = 1.25 T_{mean}$  ;  $\tau = 70 \text{ MPa} = 70 \text{ N/mm}^2$

Let  $T_{mean}$  = Mean torque transmitted by the shaft in N-m, and  
 $d$  = Diameter of the shaft in mm.

We know that the power transmitted ( $P$ ),

$$100 \times 10^3 = \frac{2 \pi N \cdot T_{mean}}{60} = \frac{2\pi \times 160 \times T_{mean}}{60} = 16.76 T_{mean}$$

$$\therefore T_{mean} = 100 \times 10^3 / 16.76 = 5966.6 \text{ N-m}$$

and maximum torque transmitted,

$$T_{max} = 1.25 \times 5966.6 = 7458 \text{ N-m} = 7458 \times 10^3 \text{ N-mm}$$

We know that maximum torque ( $T_{max}$ ),

$$7458 \times 10^3 = \frac{\pi}{16} \times \tau \times d^3 = \frac{\pi}{16} \times 70 \times d^3 = 13.75 d^3$$

$$\therefore d^3 = 7458 \times 10^3 / 13.75 = 542.4 \times 10^3 \text{ or } d = 81.5 \text{ mm Ans.}$$

### **Bending Stress**

In engineering practice, the machine parts of structural members may be subjected to static or dynamic loads which cause bending stress in the sections besides other types of stresses such as tensile, compressive and shearing stresses. Consider a straight beam subjected to a bending moment  $M$  as shown in Fig.

The following assumptions are usually made while deriving the bending formula.

1. The material of the beam is perfectly homogeneous (*i.e.* of the same material throughout) and isotropic (*i.e.* of equal elastic properties in all directions).
2. The material of the beam obeys Hooke's law.
3. The transverse sections (*i.e.*  $BC$  or  $GH$ ) which were plane before bending remain plane after bending also.
4. Each layer of the beam is free to expand or contract, independently, of the layer, above or below it.
5. The Young's modulus ( $E$ ) is the same in tension and compression.
6. The loads are applied in the plane of bending.

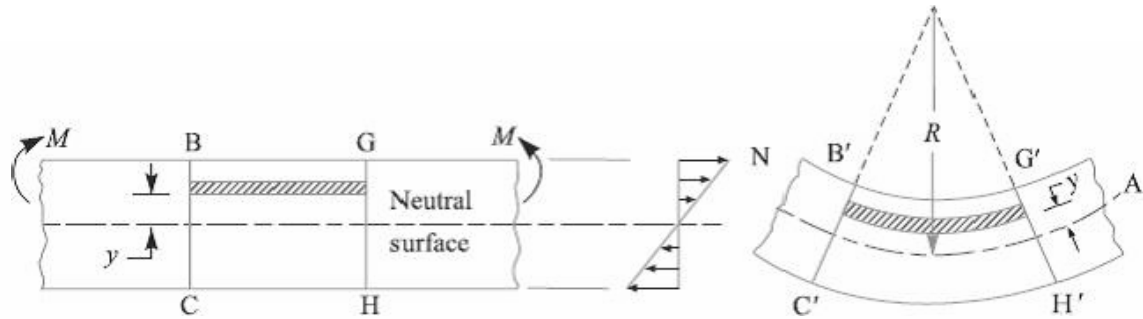

A little consideration will show that when a beam is subjected to the bending moment, the fibres on the upper side of the beam will be shortened due to compression and those on the lower side will be elongated due to tension. It may be seen that somewhere between the top and bottom fibres there is a surface at which the fibres are neither shortened nor lengthened. Such a surface is called **neutral surface**. The intersection of the neutral surface with any normal cross-section of the beam is known as **neutral axis**. The stress distribution of a beam is shown in Fig. The bending equation is given by

$$\frac{M}{I} = \frac{\sigma}{y} = \frac{E}{R}$$

Where  $M$  = Bending moment acting at the given section,  $\sigma$

= Bending stress,

$I$  = Moment of inertia of the cross-section about the neutral axis,

$y$  = Distance from the neutral axis to the extreme fibre,  $E$

= Young's modulus of the material of the beam, and  $R$

= Radius of curvature of the beam.

From the above equation, the bending stress is given by

$$\sigma = y \times \frac{E}{R}$$

Since  $E$  and  $R$  are constant, therefore within elastic limit, the stress at any point is directly proportional to  $y$ , *i.e.* the distance of the point from the neutral axis.

Also from the above equation, the bending stress,

$$\sigma = \frac{M}{I} \times y = \frac{M}{I/y} = \frac{M}{Z}$$

The ratio  $I/y$  is known as **section modulus** and is denoted by  $Z$ .

**Notes: 1.** the neutral axis of a section always passes through its centroid.

**2.** In case of symmetrical sections such as circular, square or rectangular, the neutral axis passes through its geometrical centre and the distance of extreme fibre from the neutral axis

is  $y = d/2$ , where  $d$  is the diam

or

rectangular section of square

3. In case of unsymmetrical sections such as L-section or T-section, the neutral axis does not pass through its geometrical centre. In such cases, first of all the centroid of the section is calculated and then the distance of the extreme fibres for both lower and upper side of the section is obtained. Out of these two values, the bigger value is used in bending equation.

**Problem:**

A beam of uniform rectangular cross-section is fixed at one end and carries an electric motor weighing 400 N at a distance of 300 mm from the fixed end. The maximum bending stress in the beam is 40 MPa. Find the width and depth of the beam, if depth is twice that of width.

**Solution.** Given:  $W = 400 \text{ N}$ ;  $L = 300 \text{ mm}$ ;  
 $\sigma_b = 40 \text{ MPa} = 40 \text{ N/mm}^2$ ;  $h = 2b$

The beam is shown in Fig. 5.7.

Let  $b =$  Width of the beam in mm, and  
 $h =$  Depth of the beam in mm.

$\therefore$  Section modulus,

$$Z = \frac{b \cdot h^2}{6} = \frac{b (2b)^2}{6} = \frac{2 b^3}{3} \text{ mm}^3$$

Maximum bending moment (at the fixed end),

$$M = WL = 400 \times 300 = 120 \times 10^3 \text{ N-mm}$$

We know that bending stress ( $\sigma_b$ ),

$$40 = \frac{M}{Z} = \frac{120 \times 10^3 \times 3}{2 b^3} = \frac{180 \times 10^3}{b^3}$$

$$\therefore b^3 = 180 \times 10^3 / 40 = 4.5 \times 10^3 \text{ or } b = 16.5 \text{ mm Ans.}$$

and

$$h = 2b = 2 \times 16.5 = 33 \text{ mm Ans.}$$

**Problem:**

A cast iron pulley transmits 10 kW at 400 r.p.m. The diameter of the pulley is 1.2 metre and it has four straight arms of elliptical cross-section, in which the major axis is twice the minor axis. Determine the dimensions of the arm if the allowable bending stress is 15 MPa.

**Solution.** Given :  $P = 10 \text{ kW} = 10 \times 10^3 \text{ W}$  ;  $N = 400 \text{ r.p.m}$  ;  $D = 1.2 \text{ m} = 1200 \text{ mm}$  or  
 $R = 600 \text{ mm}$  ;  $\sigma_b = 15 \text{ MPa} = 15 \text{ N/mm}^2$

Let  $T =$  Torque transmitted by the pulley.

We know that the power transmitted by the pulley ( $P$ ),

$$10 \times 10^3 = \frac{2 \pi N \cdot T}{60} = \frac{2 \pi \times 400 \times T}{60} = 42 T$$

$$\therefore T = 10 \times 10^3 / 42 = 238 \text{ N-m} = 238 \times 10^3 \text{ N-mm}$$

Since the torque transmitted is the product of the tangential load and the radius of the pulley, therefore tangential load acting on the pulley

$$= \frac{T}{R} = \frac{238 \times 10^3}{600} = 396.7 \text{ N}$$

Since the pulley has four arms, therefore tangential load on each arm,

$$W = 396.7/4 = 99.2 \text{ N}$$

and maximum bending moment on the arm,

$$M = W \times R = 99.2 \times 600 = 59\,520 \text{ N-mm}$$

Let  $2b$  = Minor axis in mm, and

$$2a = \text{Major axis in mm} = 2 \times 2b = 4b$$

...(Given)

$\therefore$  Section modulus for an elliptical cross-section,

$$Z = \frac{\pi}{4} \times a^2 b = \frac{\pi}{4} (2b)^2 \times b = \pi b^3 \text{ mm}^3$$

We know that bending stress ( $\sigma_b$ ),

$$15 = \frac{M}{Z} = \frac{59\,520}{\pi b^3} = \frac{18\,943}{b^3}$$

or  $b^3 = 18\,943/15 = 1263$  or  $b = 10.8 \text{ mm}$

$\therefore$  Minor axis,  $2b = 2 \times 10.8 = 21.6 \text{ mm Ans.}$

and major axis,  $2a = 2 \times 2b = 4 \times 10.8 = 43.2 \text{ mm Ans.}$

### **References:**

1. Machine Design - V. Bandari .
2. Machine Design – R.S. Khurmi
3. Design Data hand Book - S MD Jalaludin.

### **Principal Stresses and Principal Planes**

In the previous chapter, we have discussed about the direct tensile and compressive stress as well as simple shear. Also we have always referred the stress in a plane which is at right angles to the line of action of the force. But it has been observed that at any point in a strained material, there are three planes, mutually perpendicular to each other which carry direct stresses only and no shear stress. It may be noted that out of these three direct stresses, one will be maximum and the other will be minimum. These perpendicular planes which have no shear stress are known as *principal planes* and the direct stresses along these planes

are known as *principal stresses*. The planes on which the maximum shear stress act are known as planes of maximum shear.

### **Determination of Principal Stresses for a Member Subjected to Bi-axial Stress**

When a member is subjected to bi-axial stress (*i.e.* direct stress in two mutually perpendicular planes accompanied by a simple shear stress), then the normal and shear stresses are obtained as discussed below:

Consider a rectangular body  $ABCD$  of uniform cross-sectional area and unit thickness subjected to normal stresses  $\sigma_1$  and  $\sigma_2$  as shown in Fig. (a). In addition to these normal stresses, a shear stress  $\tau$  also acts. It has been shown in books on '*Strength of Materials*' that the normal stress across any oblique section such as  $EF$  inclined at an angle  $\theta$  with the direction of  $\sigma_2$ , as shown in Fig. (a), is given by

$$\sigma_t = \frac{\sigma_1 + \sigma_2}{2} + \frac{\sigma_1 - \sigma_2}{2} \cos 2\theta + \tau \sin 2\theta \quad \dots(i)$$

And tangential stress (*i.e.* shear stress) across the section  $EF$ ,

$$\tau_t = \frac{1}{2} (\sigma_1 - \sigma_2) \sin 2\theta - \tau \cos 2\theta \quad \dots(ii)$$

Since the planes of maximum and minimum normal stress (*i.e.* principal planes) have no shear stress, therefore the inclination of principal planes is obtained by equating  $\tau_t = 0$  in the above equation (ii), *i.e.*

$$\frac{1}{2} (\sigma_1 - \sigma_2) \sin 2\theta - \tau \cos 2\theta = 0$$
$$\tan 2\theta = \frac{2\tau}{\sigma_1 - \sigma_2} \quad \dots(iii)$$

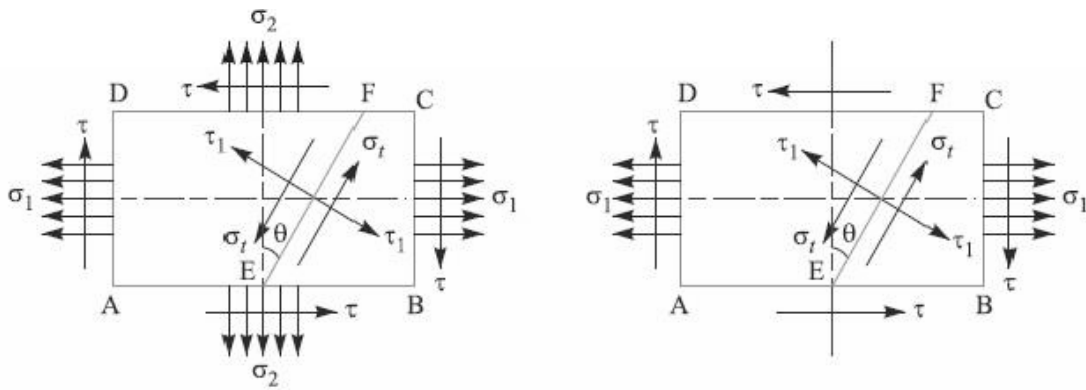

(a) Direct stress in two mutually perpendicular planes accompanied by a simple shear stress.

(b) Direct stress in one plane accompanied by a simple shear stress.

Fig. Principal stresses for a member subjected to bi-axial stress

We know that there are two principal planes at right angles to each other. Let  $\theta_1$  and  $\theta_2$  be the inclinations of these planes with the normal cross-section. From the following Fig., we find that

$$\sin 2\theta = \pm \frac{2\tau}{\sqrt{(\sigma_1 - \sigma_2)^2 + 4\tau^2}}$$

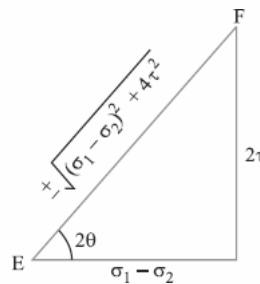

$$\therefore \sin 2\theta_1 = + \frac{2\tau}{\sqrt{(\sigma_1 - \sigma_2)^2 + 4\tau^2}}$$

and

$$\sin 2\theta_2 = - \frac{2\tau}{\sqrt{(\sigma_1 - \sigma_2)^2 + 4\tau^2}}$$

Also

$$\cos 2\theta = \pm \frac{\sigma_1 - \sigma_2}{\sqrt{(\sigma_1 - \sigma_2)^2 + 4\tau^2}}$$

$\therefore$

$$\cos 2\theta_1 = + \frac{\sigma_1 - \sigma_2}{\sqrt{(\sigma_1 - \sigma_2)^2 + 4\tau^2}}$$

and

$$\cos 2\theta_2 = - \frac{\sigma_1 - \sigma_2}{\sqrt{(\sigma_1 - \sigma_2)^2 + 4\tau^2}}$$

The maximum and minimum principal stresses may now be obtained by substituting the values of  $\sin 2\theta$  and  $\cos 2\theta$  in equation (i).

So, Maximum principal (or normal) stress,

$$\sigma_{r1} = \frac{\sigma_1 + \sigma_2}{2} + \frac{1}{2} \sqrt{(\sigma_1 - \sigma_2)^2 + 4 \tau^2} \quad \dots(iv)$$

And minimum principal (or normal) stress,

$$\sigma_{r2} = \frac{\sigma_1 + \sigma_2}{2} - \frac{1}{2} \sqrt{(\sigma_1 - \sigma_2)^2 + 4 \tau^2} \quad \dots(v)$$

The planes of maximum shear stress are at right angles to each other and are inclined at  $45^\circ$  to the principal planes. The maximum shear stress is given by *one-half the algebraic difference between the principal stresses, i.e.*

$$\tau_{max} = \frac{\sigma_1 - \sigma_2}{2} = \frac{1}{2} \sqrt{(\sigma_1 - \sigma_2)^2 + 4 \tau^2} \quad \dots(vi)$$

Notes: 1. when a member is subjected to direct stress in one plane accompanied by a simple shear stress, then the principal stresses are obtained by substituting  $\sigma_2 = 0$  in equation (iv), (v) and (vi).

$$\begin{aligned} \sigma_{r1} &= \frac{\sigma_1}{2} + \frac{1}{2} \left[ \sqrt{(\sigma_1)^2 + 4 \tau^2} \right] \\ \sigma_{r2} &= \frac{\sigma_1}{2} - \frac{1}{2} \left[ \sqrt{(\sigma_1)^2 + 4 \tau^2} \right] \\ \tau_{max} &= \frac{1}{2} \left[ \sqrt{(\sigma_1)^2 + 4 \tau^2} \right] \end{aligned}$$

2. In the above expression of  $\sigma_{r2}$ , the value of  $\frac{1}{2} \left[ \sqrt{(\sigma_1)^2 + 4 \tau^2} \right]$  is more than  $\sigma_1/2$ . Therefore the nature of  $\sigma_{r2}$  will be opposite to that of  $\sigma_{r1}$ , i.e. if  $\sigma_{r1}$  is tensile then  $\sigma_{r2}$  will be compressive and *vice-versa*.

### **Application of Principal Stresses in Designing Machine Members**

There are many cases in practice, in which machine members are subjected to combined stresses due to simultaneous action of either tensile or compressive stresses combined with shear stresses. In many shafts such as propeller shafts, C-frames etc., there are direct tensile or compressive stresses due to the external force and shear stress due to torsion, which acts

normal to direct tensile or compressive stresses. The shafts like crank shafts, are subjected simultaneously to torsion and bending. In such cases, the maximum principal stresses, due to the combination of tensile or compressive stresses with shear stresses may be obtained. The results obtained in the previous article may be written as follows:

1. Maximum tensile stress,

$$\sigma_{t(max)} = \frac{\sigma_t}{2} + \frac{1}{2} \left[ \sqrt{(\sigma_t)^2 + 4 \tau^2} \right]$$

2. Maximum compressive stress,

$$\sigma_{c(max)} = \frac{\sigma_c}{2} - \frac{1}{2} \left[ \sqrt{(\sigma_c)^2 + 4 \tau^2} \right]$$

3. Maximum shear stress,

$$\tau_{max} = \frac{1}{2} \left[ \sqrt{(\sigma_t)^2 + 4 \tau^2} \right]$$

Where  $\sigma_t$  = Tensile stress due to direct load and bending,

$\sigma_c$  = Compressive stress, and

$\tau$  = Shear stress due to torsion.

**Notes:** 1. When  $\tau = 0$  as in the case of thin cylindrical shell subjected in internal fluid pressure, then  $\sigma_{tmax} = \sigma_t$

2. When the shaft is subjected to an axial load ( $P$ ) in addition to bending and twisting moments as in the propeller shafts of ship and shafts for driving worm gears, then the stress due to axial load must be added to the bending stress ( $\sigma_b$ ). This will give the resultant tensile stress or compressive stress ( $\sigma_t$  or  $\sigma_c$ ) depending upon the type of axial load (*i.e.* pull or push).

**Problem:**

A shaft, as shown in Fig., is subjected to a bending load of 3 kN, pure torque of 1000 N-m and an axial pulling force of 15 kN. Calculate the stresses at A and B.

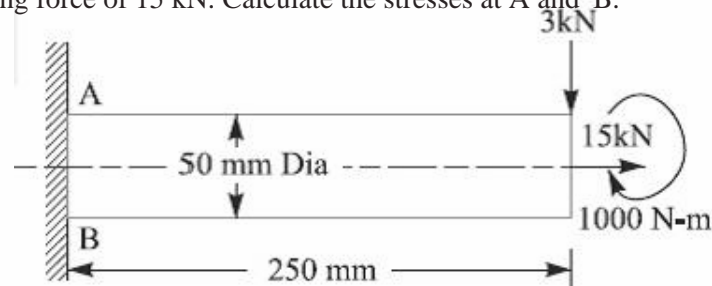



**Solution.** Given :  $W = 3 \text{ kN} = 3000 \text{ N}$  ;  
 $T = 1000 \text{ N-m} = 1 \times 10^6 \text{ N-mm}$  ;  $P = 15 \text{ kN}$   
 $= 15 \times 10^3 \text{ N}$  ;  $d = 50 \text{ mm}$  ;  $x = 250 \text{ mm}$

We know that cross-sectional area of the shaft,

$$A = \frac{\pi}{4} \times d^2$$

$$= \frac{\pi}{4} (50)^2 = 1964 \text{ mm}^2$$

$\therefore$  Tensile stress due to axial pulling at points  $A$  and  $B$ ,

$$\sigma_o = \frac{P}{A} = \frac{15 \times 10^3}{1964} = 7.64 \text{ N/mm}^2 = 7.64 \text{ MPa}$$

Bending moment at points  $A$  and  $B$ ,

$$M = W \cdot x = 3000 \times 250 = 750 \times 10^3 \text{ N-mm}$$

Section modulus for the shaft,

$$Z = \frac{\pi}{32} \times d^3 = \frac{\pi}{32} (50)^3$$

$$= 12.27 \times 10^3 \text{ mm}^3$$

$\therefore$  Bending stress at points  $A$  and  $B$ ,

$$\sigma_b = \frac{M}{Z} = \frac{750 \times 10^3}{12.27 \times 10^3}$$

$$= 61.1 \text{ N/mm}^2 = 61.1 \text{ MPa}$$

This bending stress is tensile at point  $A$  and compressive at point  $B$ .

$\therefore$  Resultant tensile stress at point  $A$ ,

$$\sigma_A = \sigma_b + \sigma_o = 61.1 + 7.64$$

$$= 68.74 \text{ MPa}$$

and resultant compressive stress at point  $B$ ,

$$\sigma_B = \sigma_b - \sigma_o = 61.1 - 7.64 = 53.46 \text{ MPa}$$

We know that the shear stress at points  $A$  and  $B$  due to the torque transmitted,

$$\tau = \frac{16 T}{\pi d^3} = \frac{16 \times 1 \times 10^6}{\pi (50)^3} = 40.74 \text{ N/mm}^2 = 40.74 \text{ MPa} \quad \dots \left( \because T = \frac{\pi}{16} \times \tau \times d^3 \right)$$

### Stresses at point A

We know that maximum principal (or normal) stress at point A,

$$\begin{aligned}\sigma_{A(max)} &= \frac{\sigma_A}{2} + \frac{1}{2} \left[ \sqrt{(\sigma_A)^2 + 4 \tau^2} \right] \\ &= \frac{68.74}{2} + \frac{1}{2} \left[ \sqrt{(68.74)^2 + 4 (40.74)^2} \right] \\ &= 34.37 + 53.3 = 87.67 \text{ MPa (tensile) Ans.}\end{aligned}$$

Minimum principal (or normal) stress at point A,

$$\begin{aligned}\sigma_{A(min)} &= \frac{\sigma_A}{2} - \frac{1}{2} \left[ \sqrt{(\sigma_A)^2 + 4 \tau^2} \right] = 34.37 - 53.3 = -18.93 \text{ MPa} \\ &= 18.93 \text{ MPa (compressive) Ans.}\end{aligned}$$

and maximum shear stress at point A,

$$\begin{aligned}\tau_{A(max)} &= \frac{1}{2} \left[ \sqrt{(\sigma_A)^2 + 4 \tau^2} \right] = \frac{1}{2} \left[ \sqrt{(68.74)^2 + 4 (40.74)^2} \right] \\ &= 53.3 \text{ MPa Ans.}\end{aligned}$$

### Stresses at point B

We know that maximum principal (or normal) stress at point B,

$$\begin{aligned}\sigma_{B(max)} &= \frac{\sigma_B}{2} + \frac{1}{2} \left[ \sqrt{(\sigma_B)^2 + 4 \tau^2} \right] \\ &= \frac{53.46}{2} + \frac{1}{2} \left[ \sqrt{(53.46)^2 + 4 (40.74)^2} \right] \\ &= 26.73 + 48.73 = 75.46 \text{ MPa (compressive) Ans.}\end{aligned}$$

Minimum principal (or normal) stress at point B,

$$\begin{aligned}\sigma_{B(min)} &= \frac{\sigma_B}{2} - \frac{1}{2} \left[ \sqrt{(\sigma_B)^2 + 4 \tau^2} \right] \\ &= 26.73 - 48.73 = -22 \text{ MPa} \\ &= 22 \text{ MPa (tensile) Ans.}\end{aligned}$$

and maximum shear stress at point B,

$$\begin{aligned}\tau_{B(max)} &= \frac{1}{2} \left[ \sqrt{(\sigma_B)^2 + 4 \tau^2} \right] = \frac{1}{2} \left[ \sqrt{(53.46)^2 + 4 (40.74)^2} \right] \\ &= 48.73 \text{ MPa Ans.}\end{aligned}$$

### References:

1. Machine Design - V.Bandari .
2. Machine Design – R.S. Khurmi
3. Design Data hand Book - S MD Jalaludin.

### **Factor of Safety**

It is defined, in general, as the **ratio of the maximum stress to the working stress**.

Mathematically,

$$\text{Factor of safety} = \text{Maximum stress} / \text{Working or design stress}$$

In case of ductile materials *e.g.* mild steel, where the yield point is clearly defined, the factor of safety is based upon the yield point stress. In such cases,

$$\text{Factor of safety} = \text{Yield point stress} / \text{Working or design stress}$$

In case of brittle materials *e.g.* cast iron, the yield point is not well defined as for ductile materials. Therefore, the factor of safety for brittle materials is based on ultimate stress.

$$\text{Factor of safety} = \text{Ultimate stress} / \text{Working or design stress}$$

This relation may also be used for ductile materials.

The above relations for factor of safety are for static loading.

### **Design for strength and rigidity:**

#### **Design for strength:**

All the concepts discussed so far and the problems done are strength based, i.e., there will be some permissible stress or strength and our task is to limit the stresses below the given permissible value and accordingly sizing the machine element.

#### **Design for rigidity or stiffness:**

It is the ability to resist deformations under the action of external load. Along with strength, rigidity is also a very important operating property of many machine components. Ex: helical and leaf springs, elastic elements in various instruments, shafts, bearings, toothed and worm gears and so on.

In many cases, this parameter of operating capacity proves to be most important and to ensure it the dimensions of the part have to be increased to such an extent that the actual induced stresses become much lower than the allowable ones. Rigidity is also necessary to ensure that the mated parts and the machine as a whole operate effectively.

Forces subject the parts to elastic deformations: shafts are bent and twisted, bolts are stretched etc.,

1. When a shaft is deflected, its journals are misaligned in the bearings thereby causing the uneven wear of the shells, heating and seizure in the sliding bearings.
2. Deflections and angles of turn of shafts at the places where gears are fitted cause non-uniform load distribution over the length of the teeth.

3. With the deflection of an insufficiently rigid shaft, the operating conditions or antifriction bearings sharply deteriorate if the bearings cannot self-aligning.
4. Rigidity is particularly important for ensuring the adequate accuracy of items produced on machine tools.

Rigidity of machine elements is found with the help of formulae from the theory of strength of materials. The actual displacements like deflections, angles of turn, angles of twist should not be more than the allowable values. The most important design methods for increasing the rigidity of machine elements are as follows.

- a) The decrease in the arms of bending and twisting forces.
- b) The incorporation of additional supports.
- c) The application of cross sections which effectively resist torsion (closed tubular) and bending (in which the cross section is removed as far as possible from the neutral axis).
- d) The decrease of the length of the parts in tension and the increase of their cross section area.

From the above it's clear that the stiffness of a member depends not only on the shape and size of its cross section but also on elastic modulus of the material used.

### **Preferred Numbers**

When a machine is to be made in several sizes with different powers or capacities, it is necessary to decide what capacities will cover a certain range efficiently with minimum number of sizes. It has been shown by experience that a certain range can be covered efficiently when it follows a geometrical progression with a constant ratio. The preferred numbers are the conventionally rounded off values derived from geometric series including the integral powers of 10 and having as common ratio of the following factors:

$$\sqrt[5]{10}, \sqrt[10]{10}, \sqrt[20]{10}, \sqrt[40]{10}$$

These ratios are approximately equal to 1.58, 1.26, 1.12 and 1.06. The series of preferred numbers are designated as \*R5, R10, R20 and R40 respectively. These four series are called *basic series*. The other series called *derived series* may be obtained by simply multiplying or dividing the basic sizes by 10, 100, etc. The preferred numbers in the series R5 are 1, 1.6, 2.5, 4.0 and 6.3.

### **References:**

1. Machine Design - V.Bandari .
2. Machine Design – R.S. Khurmi

**The concept of stiffness in tension, bending, torsion, and combined situations**

**Stiffness in tension:**

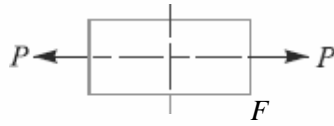

$$\epsilon = \frac{\sigma}{E} = \frac{F}{EA} = \frac{4}{E} \frac{\pi d^2}{4}$$

$\delta l$  may be a constraint or  $\delta A$  may be a constraint

**Stiffness in Bending:**

$\delta, d, \theta$  may be constraints

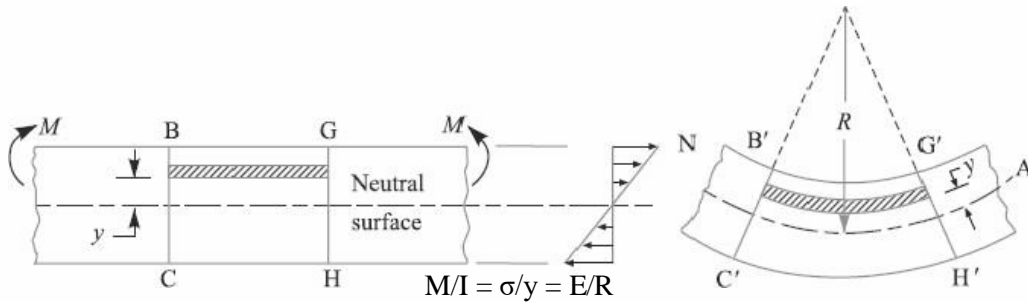

**Stiffness in Torsion:**

$\theta$  may be a constraint.

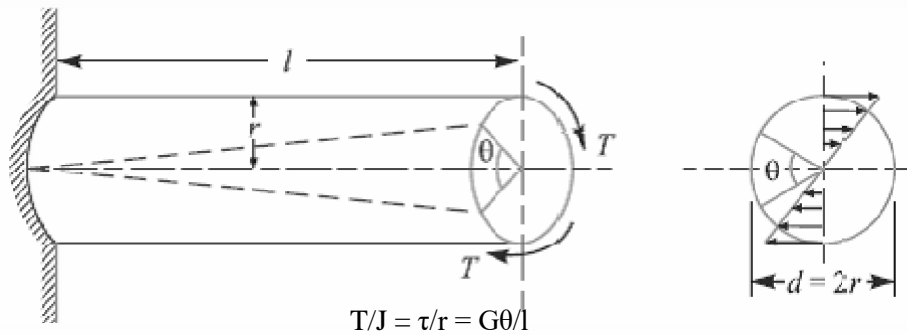

**Combined situations:**

$\sigma_1, \sigma_2,$  and  $\tau_{max}$  any one or two may be constraints. Then control the elements of the formulae like  $\sigma, \tau$  by adjusting the geometry of the machine element or changing the type of material used which changes  $E$ .

$$\sigma_{f1} = \frac{\sigma_1 + \sigma_2}{2} + \frac{1}{2} \sqrt{(\sigma_1 - \sigma_2)^2 + 4 \tau^2}$$

$$\sigma_{r2} = \frac{\sigma_1 + \sigma_2}{2} - \frac{1}{2} \sqrt{(\sigma_1 - \sigma_2)^2 + 4 \tau^2}$$
$$\tau_{max} = \frac{\sigma_1 - \sigma_2}{2} = \frac{1}{2} \sqrt{(\sigma_1 - \sigma_2)^2 + 4 \tau^2}$$

**References:**

1. Machine Design - V.Bandari .
2. Machine Design – R.S. Khurmi
3. Design Data hand Book - S MD Jalaludin

## UNIT 2

### Design for Fatigue Strength

#### **Stress Concentration:**

Whenever a machine component changes the shape of its cross-section, the simple stress distribution no longer holds good and the neighborhood of the discontinuity is different. This irregularity in the stress distribution caused by abrupt changes of form is called **stress concentration**. It occurs for all kinds of stresses in the presence of fillets, notches, holes, keyways, splines, surface roughness or scratches etc. In order to understand fully the idea of stress concentration, consider a member with different cross-section under a tensile load as shown in Fig. A little consideration will show that the nominal stress in the right and left hand sides will be uniform but in the region where the cross-section is changing, a re-distribution of the force within the member must take place. The material near the edges is stressed considerably higher than the average value. The maximum stress occurs at some point on the fillet and is directed parallel to the boundary at that point.

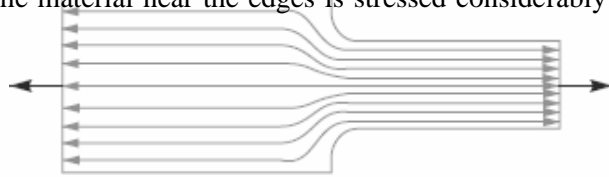

Fig. Stress concentration

#### **Theoretical or Form Stress Concentration Factor**

The theoretical or form stress concentration factor is defined as the ratio of the maximum stress in a member (at a notch or a fillet) to the nominal stress at the same section based upon net area. Mathematically, theoretical or form stress concentration factor,

$$K_t = \text{Maximum stress} / \text{Nominal stress}$$

The value of  $K_t$  depends upon the material and geometry of the part. In static loading, stress concentration in ductile materials is not so serious as in brittle materials, because in ductile materials local deformation or yielding takes place which reduces the concentration. In brittle materials, cracks may appear at these local concentrations of stress which will increase the stress over the rest of the section. It is, therefore, necessary that in designing parts of brittle materials such as castings, care should be taken. In order to avoid failure due to stress concentration, fillets at the changes of section must be provided.

In cyclic loading, stress concentration in ductile materials is always serious because the ductility of the material is not effective in relieving the concentration of stress caused by cracks, flaws, surface roughness, or any sharp discontinuity in the geometrical form of the member. If the stress at any point in a member is above the endurance limit of the material, a

crack may develop under the action of repeated load and the crack will lead to failure of the member.

**Stress Concentration due to Holes and Notches**

Consider a plate with transverse elliptical hole and subjected to a tensile load as shown in Fig.1(a). We see from the stress-distribution that the stress at the point away from the hole is practically uniform and the maximum stress will be induced at the edge of the hole. The maximum stress is given by

$$\sigma_{max} = \sigma \left( 1 + \frac{2a}{b} \right)$$

And the theoretical stress concentration factor,

$$K_t = \frac{\sigma_{max}}{\sigma} = \left( 1 + \frac{2a}{b} \right)$$

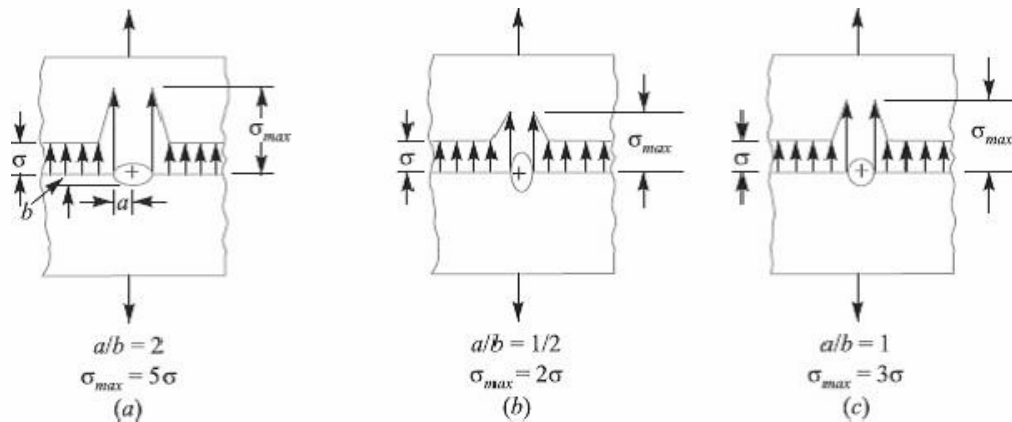

Fig.1. Stress concentration due to holes.

The stress concentration in the notched tension member, as shown in Fig. 2, is influenced by the depth *a* of the notch and radius *r* at the bottom of the notch. The maximum stress, which applies to members having notches that are small in comparison with the width of the plate, may be obtained by the following equation,

$$\sigma_{max} = \sigma \left( 1 + \frac{2a}{r} \right)$$

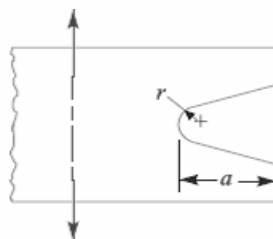

Fig.2. Stress concentration due to notches.



**Methods of Reducing Stress Concentration**

Whenever there is a change in cross-section, such as shoulders, holes, notches or keyways and where there is an interference fit between a hub or bearing race and a shaft, then stress concentration results. The presence of stress concentration can not be totally eliminated but it may be reduced to some extent. A device or concept that is useful in assisting a design engineer to visualize the presence of stress concentration and how it may be mitigated is that of stress flow lines, as shown in Fig.3. The mitigation of stress concentration means that the stress flow lines shall maintain their spacing as far as possible.

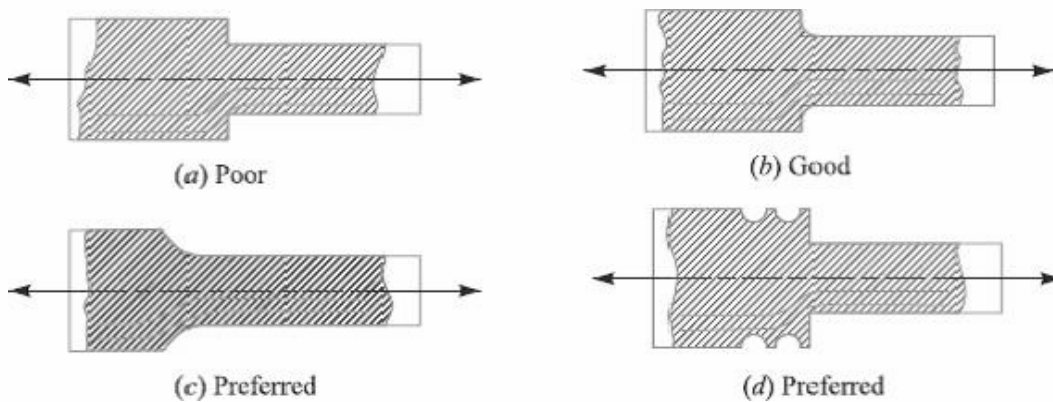

Fig.3

In Fig. 3 (a) we see that stress lines tend to bunch up and cut very close to the sharp re-entrant corner. In order to improve the situation, fillets may be provided, as shown in Fig. 3 (b) and (c) to give more equally spaced flow lines.

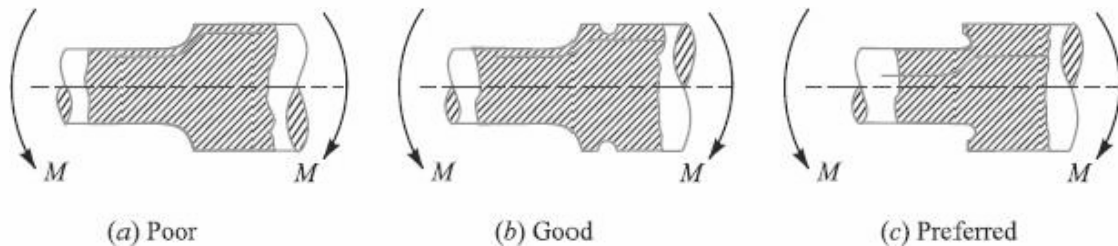

Fig. reducing stress concentration in cylindrical members with shoulders



Fig. Reducing stress concentration in cylindrical members with holes.

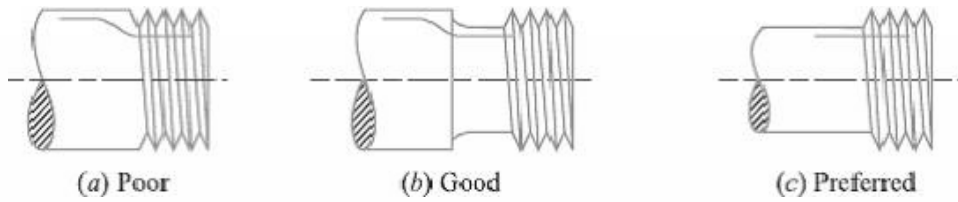

Fig. Reducing stress concentration in cylindrical members with holes

**References:**

1. Machine Design - V.Bandari .
2. Machine Design – R.S. Khurmi
3. Design Data hand Book - S MD Jalaludin

### Completely Reversed or Cyclic Stresses

Consider a rotating beam of circular cross-section and carrying a load  $W$ , as shown in Fig1. This load induces stresses in the beam which are cyclic in nature. A little consideration will show that the upper fibres of the beam (*i.e.* at point  $A$ ) are under compressive stress and the lower fibres (*i.e.* at point  $B$ ) are under tensile stress. After half a revolution, the point  $B$  occupies the position of point  $A$  and the point  $A$  occupies the position of point  $B$ . Thus the point  $B$  is now under compressive stress and the point  $A$  under tensile stress. The speed of variation of these stresses depends upon the speed of the beam.

From above we see that for each revolution of the beam, the stresses are reversed from compressive to tensile. The stresses which vary from one value of compressive to the same value of tensile or *vice versa*, are known as **completely reversed** or **cyclic stresses**. The stresses which vary from a minimum value to a maximum value of the same nature, (*i.e.* tensile or compressive) are called **fluctuating stresses**. The stresses which vary from zero to a certain maximum value are called **repeated stresses**. The stresses which vary from a minimum value to a maximum value of the opposite nature (*i.e.* from a certain minimum compressive to a certain maximum tensile or from a minimum tensile to a maximum compressive) are called **alternating stresses**.

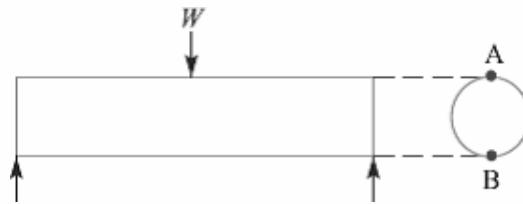

Fig.1. Shaft subjected to cyclic load

### Fatigue and Endurance Limit

It has been found experimentally that when a material is subjected to repeated stresses; it fails at stresses below the yield point stresses. Such type of failure of a material is known as **fatigue**. The failure is caused by means of a progressive crack formation which are usually fine and of microscopic size. The failure may occur even without any prior indication. The fatigue of material is effected by the size of the component, relative magnitude of static and fluctuating loads and the number of load reversals.

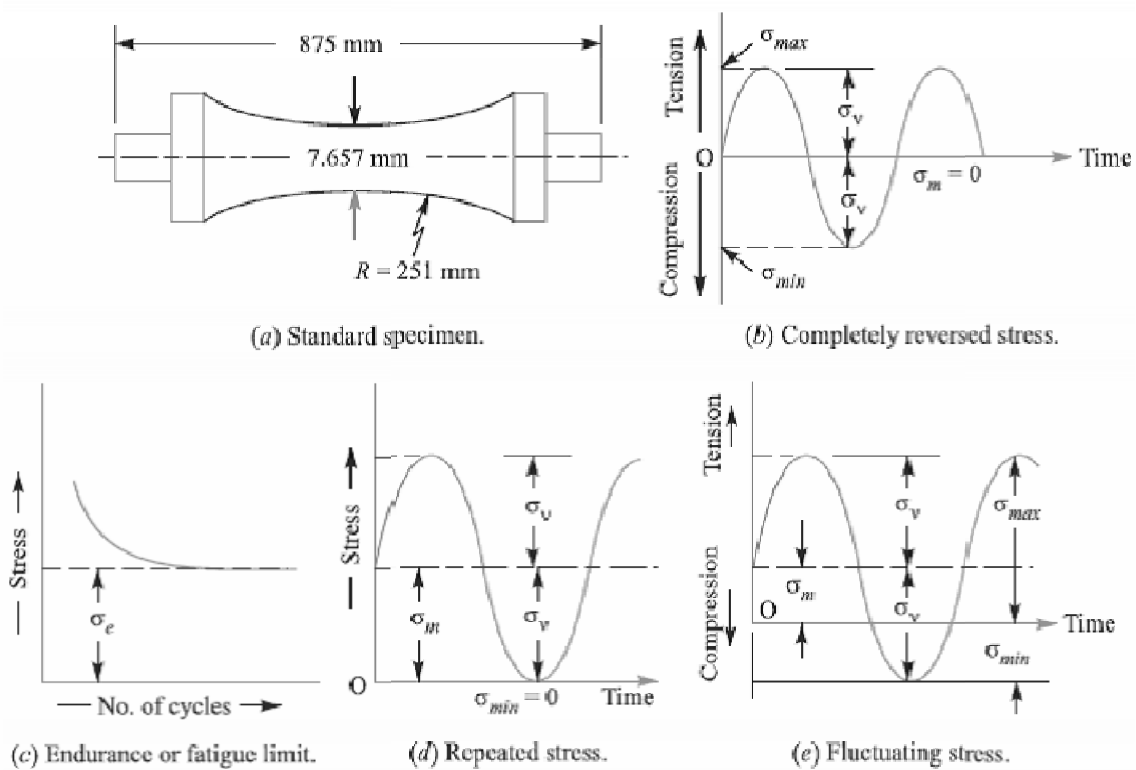

Fig.2. Time-stress diagrams.

In order to study the effect of fatigue of a material, a rotating mirror beam method is used. In this method, a standard mirror polished specimen, as shown in Fig.2 (a), is rotated in a fatigue testing machine while the specimen is loaded in bending. As the specimen rotates, the bending stress at the upper fibres varies from maximum compressive to maximum tensile while the bending stress at the lower fibres varies from maximum tensile to maximum compressive. In other words, the specimen is subjected to a completely reversed stress cycle.

This is represented by a time-stress diagram as shown in Fig.2 (b). A record is kept of the number of cycles required to produce failure at a given stress, and the results are plotted in stress-cycle curve as shown in Fig.2 (c). A little consideration will show that if the stress is kept below a certain value as shown by dotted line in Fig.2 (c), the material will not fail whatever may be the number of cycles. This stress, as represented by dotted line, is known as **endurance** or **fatigue limit** ( $\sigma_e$ ). It is defined as maximum value of the completely reversed bending stress which a polished standard specimen can withstand without failure, for infinite number of cycles (usually 107 cycles).

It may be noted that the term endurance limit is used for reversed bending only while for other types of loading, the term **endurance strength** may be used when referring the

fatigue strength of the material. It may be defined as the safe maximum stress which can be applied to the machine part working under actual conditions.

We have seen that when a machine member is subjected to a completely reversed stress, the maximum stress in tension is equal to the maximum stress in compression as shown in Fig.2 (b). In actual practice, many machine members undergo different range of stress than the completely reversed stress. The stress *verses* time diagram for fluctuating stress having values  $\sigma_{min}$  and  $\sigma_{max}$  is shown in Fig.2 (e). The variable stress, in general, may be considered as a combination of steady (or mean or average) stress and a completely reversed stress component  $\sigma_v$ . The following relations are derived from Fig. 2 (e):

1. Mean or average stress,

$$\sigma_m = \frac{\sigma_{max} + \sigma_{min}}{2}$$

2. Reversed stress component or alternating or variable stress,

$$\sigma_v = \frac{\sigma_{max} - \sigma_{min}}{2}$$

For repeated loading, the stress varies from maximum to zero (*i.e.*  $\sigma_{min} = 0$ ) in each cycle as shown in Fig.2 (d).

$$\sigma_m = \sigma_v = \frac{\sigma_{max}}{2}$$

3. Stress ratio,  $R = \sigma_{max}/\sigma_{min}$ . For completely reversed stresses,  $R = -1$  and for repeated stresses,  $R = 0$ . It may be noted that  $R$  cannot be greater than unity.

4. The following relation between endurance limit and stress ratio may be used

$$\sigma'_e = \frac{3\sigma_e}{2 - R}$$

### **Effect of Loading on Endurance Limit—Load Factor**

The endurance limit ( $\sigma_e$ ) of a material as determined by the rotating beam method is for reversed bending load. There are many machine members which are subjected to loads other than reversed bending loads. Thus the endurance limit will also be different for different types of loading. The endurance limit depending upon the type of loading may be modified as discussed below:

Let  $K_b$  = Load correction factor for the reversed or rotating bending load. Its value is usually taken as unity.

$K_a$  = Load correction factor for the reversed axial load. Its value may be taken as 0.8.

$K_s$  = Load correction factor for the reversed torsional or shear load. Its value may be taken as 0.55 for ductile materials and 0.8 for brittle materials.

$$\begin{aligned} \therefore \text{Endurance limit for reversed bending load,} & \quad \sigma_{eb} = \sigma_e K_b = \sigma_e \\ \text{Endurance limit for reversed axial load,} & \quad \sigma_{ea} = \sigma_e K_a \\ \text{and endurance limit for reversed torsional or shear load,} & \quad \tau_e = \sigma_e K_s \end{aligned}$$

### Effect of Surface Finish on Endurance Limit—Surface Finish Factor

When a machine member is subjected to variable loads, the endurance limit of the material for that member depends upon the surface conditions. Fig. shows the values of surface finish factor for the various surface conditions and ultimate tensile strength.

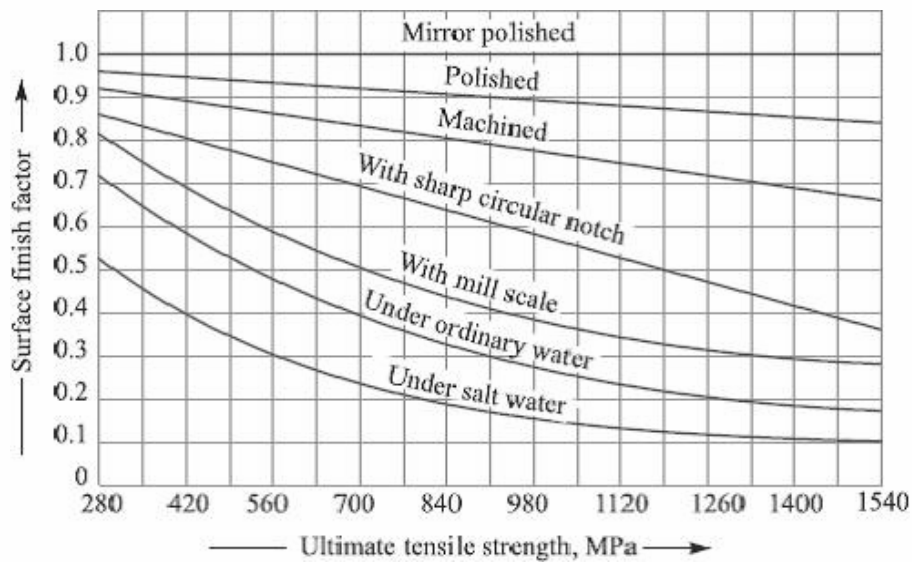

When the surface finish factor is known, then the endurance limit for the material of the machine member may be obtained by multiplying the endurance limit and the surface finish factor. We see that for a mirror polished material, the surface finish factor is unity. In other words, the endurance limit for mirror polished material is maximum and it goes on reducing due to surface condition.

Let  $K_{sur}$  = Surface finish factor.

Then, Endurance limit,

$$\begin{aligned} \sigma_{e1} &= \sigma_{eb} \cdot K_{sur} = \sigma_e K_b \cdot K_{sur} = \sigma_e K_{sur} && \dots (\because K_b = 1) \\ & && \dots (\text{For reversed bending load}) \\ &= \sigma_{ea} \cdot K_{sur} = \sigma_e K_a \cdot K_{sur} && \dots (\text{For reversed axial load}) \\ &= \tau_e K_{sur} = \sigma_e K_s \cdot K_{sur} && \dots (\text{For reversed torsional or shear load}) \end{aligned}$$

### **Effect of Size on Endurance Limit—Size Factor**

A little consideration will show that if the size of the standard specimen as shown in Fig.2 (a) is increased, then the endurance limit of the material will decrease. This is due to the fact that a longer specimen will have more defects than a smaller one.

Let  $K_{sz}$  = Size factor.

Then, Endurance limit,

$$\begin{aligned}\sigma_{e2} &= \sigma_{e1} \times K_{sz} && \dots(\text{Considering surface finish factor also}) \\ &= \sigma_{eb} \cdot K_{sur} \cdot K_{sz} = \sigma_e \cdot K_b \cdot K_{sur} \cdot K_{sz} = \sigma_e \cdot K_{sur} \cdot K_{sz} && (\because K_b = 1) \\ &= \sigma_{ea} \cdot K_{sur} \cdot K_{sz} = \sigma_e \cdot K_a \cdot K_{sur} \cdot K_{sz} && \dots(\text{For reversed axial load}) \\ &= \tau_e \cdot K_{sur} \cdot K_{sz} = \sigma_e \cdot K_s \cdot K_{sur} \cdot K_{sz} && \dots(\text{For reversed torsional or shear load})\end{aligned}$$

The value of size factor is taken as unity for the standard specimen having nominal diameter of 7.657 mm. When the nominal diameter of the specimen is more than 7.657 mm but less than 50 mm, the value of size factor may be taken as 0.85. When the nominal diameter of the specimen is more than 50 mm, then the value of size factor may be taken as 0.75.

### **Effect of Miscellaneous Factors on Endurance Limit**

In addition to the surface finish factor ( $K_{sur}$ ), size factor ( $K_{sz}$ ) and load factors  $K_b$ ,  $K_a$  and  $K_s$ , there are many other factors such as reliability factor ( $K_r$ ), temperature factor ( $K_t$ ), impact factor ( $K_i$ ) etc. which has effect on the endurance limit of a material. Considering all these factors, the endurance limit may be determined by using the following expressions:

1. For the reversed bending load, endurance limit,

$$\sigma'_e = \sigma_{eb} \cdot K_{sur} \cdot K_{sz} \cdot K_r \cdot K_t \cdot K_i$$

2. For the reversed axial load, endurance limit,

$$\sigma'_e = \sigma_{ea} \cdot K_{sur} \cdot K_{sz} \cdot K_r \cdot K_t \cdot K_i$$

3. For the reversed torsional or shear load, endurance limit,

$$\sigma'_e = \tau_e \cdot K_{sur} \cdot K_{sz} \cdot K_r \cdot K_t \cdot K_i$$

In solving problems, if the value of any of the above factors is not known, it may be taken as unity.

### **Relation between Endurance Limit and Ultimate Tensile Strength**

It has been found experimentally that endurance limit ( $\sigma_e$ ) of a material subjected to fatigue loading is a function of ultimate tensile strength ( $\sigma_u$ ).

For steel,	$\sigma_e = 0.5 \sigma_u$ ;
For cast steel,	$\sigma_e = 0.4 \sigma_u$ ;
For cast iron,	$\sigma_e = 0.35 \sigma_u$ ;
For non-ferrous metals and alloys,	$\sigma_e = 0.3 \sigma_u$

### **Factor of Safety for Fatigue Loading**

When a component is subjected to fatigue loading, the endurance limit is the criterion for failure. Therefore, the factor of safety should be based on endurance limit. Mathematically,

$$\text{Factor of safety (F.S.)} = \frac{\text{Endurance limit stress}}{\text{Design or working stress}} = \frac{\sigma_e}{\sigma_d}$$

For steel,  $\sigma_e = 0.8 \text{ to } 0.9 \sigma_y$   
 $\sigma_e$  = Endurance limit stress for completely reversed stress cycle, and  
 $\sigma_y$  = Yield point stress.

### **Fatigue Stress Concentration Factor**

When a machine member is subjected to cyclic or fatigue loading, the value of fatigue stress concentration factor shall be applied instead of theoretical stress concentration factor. Since the determination of fatigue stress concentration factor is not an easy task, therefore from experimental tests it is defined as

Fatigue stress concentration factor,

$$K_f = \frac{\text{Endurance limit without stress concentration}}{\text{Endurance limit with stress concentration}}$$

### **Notch Sensitivity**

In cyclic loading, the effect of the notch or the fillet is usually less than predicted by the use of the theoretical factors as discussed before. The difference depends upon the stress gradient in the region of the stress concentration and on the hardness of the material. The term ***notch sensitivity*** is applied to this behaviour. It may be defined as the degree to which the theoretical effect of stress concentration is actually reached. The stress gradient depends mainly on the radius of the notch, hole or fillet and on the grain size of the material. Since the extensive data for estimating the notch sensitivity factor ( $q$ ) is not available, therefore the curves, as shown in Fig., may be used for determining the values of  $q$  for two steels. When the notch sensitivity factor  $q$  is used in cyclic loading, then fatigue stress concentration factor may be obtained from the following relations:

$$q = \frac{K_f - 1}{K_t - 1}$$

Or



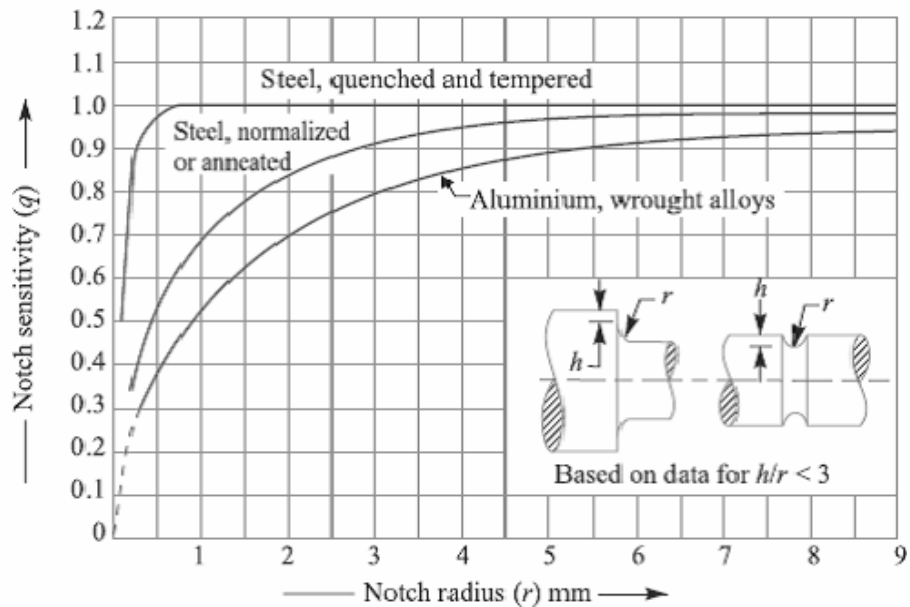

$$K_f = 1 + q (K_t - 1) \quad \dots[\text{For tensile or bending stress}]$$

And

$$K_{fs} = 1 + q (K_{ts} - 1) \quad \dots[\text{For shear stress}]$$

Where  $K_t$  = Theoretical stress concentration factor for axial or bending loading, and  $K_{ts}$  = Theoretical stress concentration factor for torsional or shear loading.

**References:**

1. Machine Design - V.Bandari .
2. Machine Design – R.S. Khurmi
3. Design Data hand Book - S MD Jalaludin.

Problem: Determine the thickness of a 120 mm wide uniform plate for safe continuous operation if the plate is to be subjected to a tensile load that has a maximum value of 250 kN and a minimum value of 100 kN. The properties of the plate material are as follows: Endurance limit stress = 225 MPa, and Yield point stress = 300 MPa. The factor of safety based on yield point may be taken as 1.5.

Let  $t = \text{Thickness of the plate in mm.}$

$$\therefore \text{Area, } A = b \times t = 120 t \text{ mm}^2$$

We know that mean or average load,

$$W_m = \frac{W_{max} + W_{min}}{2} = \frac{250 + 100}{2} = 175 \text{ kN} = 175 \times 10^3 \text{ N}$$

$$\therefore \text{Mean stress, } \sigma_m = \frac{W_m}{A} = \frac{175 \times 10^3}{120 t} \text{ N/mm}^2$$

$$\text{Variable load, } W_v = \frac{W_{max} - W_{min}}{2} = \frac{250 - 100}{2} = 75 \text{ kN} = 75 \times 10^3 \text{ N}$$

$$\therefore \text{Variable stress, } \sigma_v = \frac{W_v}{A} = \frac{75 \times 10^3}{120 t} \text{ N/mm}^2$$

According to Soderberg's formula,

$$\frac{1}{F.S.} = \frac{\sigma_m}{\sigma_y} + \frac{\sigma_v}{\sigma_e}$$

$$\frac{1}{1.5} = \frac{175 \times 10^3}{120 t \times 300} + \frac{75 \times 10^3}{120 t \times 225} = \frac{4.86}{t} + \frac{2.78}{t} = \frac{7.64}{t}$$

$$\therefore t = 7.64 \times 1.5 = 11.46 \text{ say } 11.5 \text{ mm Ans.}$$

Problem:

Determine the diameter of a circular rod made of ductile material with a fatigue strength (complete stress reversal),  $\sigma_e = 265 \text{ MPa}$  and a tensile yield strength of 350 MPa. The member is subjected to a varying axial load from  $W_{min} = -300 \times 10^3 \text{ N}$  to  $W_{max} = 700 \times 10^3 \text{ N}$  and has a stress concentration factor = 1.8. Use factor of safety as 2.0.

Let  $d = \text{Diameter of the circular rod in mm.}$

$$\therefore \text{Area, } A = \frac{\pi}{4} \times d^2 = 0.7854 d^2 \text{ mm}^2$$

We know that the mean or average load,

$$W_m = \frac{W_{max} + W_{min}}{2} = \frac{700 \times 10^3 + (-300 \times 10^3)}{2} = 200 \times 10^3 \text{ N}$$

$$\therefore \text{Mean stress, } \sigma_m = \frac{W_m}{A} = \frac{200 \times 10^3}{0.7854 d^2} = \frac{254.6 \times 10^3}{d^2} \text{ N/mm}^2$$

Variable load, 
$$W_v = \frac{W_{max} - W_{min}}{2} = \frac{700 \times 10^3 - (-300 \times 10^3)}{2} = 500 \times 10^3 \text{ N}$$

$\therefore$  Variable stress, 
$$\sigma_v = \frac{W_v}{A} = \frac{500 \times 10^3}{0.7854 d^2} = \frac{636.5 \times 10^3}{d^2} \text{ N/mm}^2$$

We know that according to Soderberg's formula,

$$\frac{1}{F.S.} = \frac{\sigma_m}{\sigma_y} + \frac{\sigma_v \times K_f}{\sigma_e}$$

$$\frac{1}{2} = \frac{254.6 \times 10^3}{d^2 \times 350} + \frac{636.5 \times 10^3 \times 1.8}{d^2 \times 265} = \frac{727}{d^2} + \frac{4323}{d^2} = \frac{5050}{d^2}$$

$\therefore d^2 = 5050 \times 2 = 10100$  or  $d = 100.5 \text{ mm Ans.}$

Problem:

A circular bar of 500 mm length is supported freely at its two ends. It is acted upon by a central concentrated cyclic load having a minimum value of 20 kN and a maximum value of 50 kN. Determine the diameter of bar by taking a factor of safety of 1.5, size effect of 0.85, surface finish factor of 0.9. The material properties of bar are given by: ultimate strength of 650 MPa, yield strength of 500 MPa and endurance strength of 350 MPa.

**Solution.** Given :  $l = 500 \text{ mm}$  ;  $W_{min} = 20 \text{ kN} = 20 \times 10^3 \text{ N}$  ;  $W_{max} = 50 \text{ kN} = 50 \times 10^3 \text{ N}$  ;  
 $F.S. = 1.5$  ;  $K_{sz} = 0.85$  ;  $K_{surf} = 0.9$  ;  $\sigma_u = 650 \text{ MPa} = 650 \text{ N/mm}^2$  ;  $\sigma_y = 500 \text{ MPa} = 500 \text{ N/mm}^2$  ;  
 $\sigma_e = 350 \text{ MPa} = 350 \text{ N/mm}^2$

Let  $d = \text{Diameter of the bar in mm.}$

We know that the maximum bending moment,

$$M_{max} = \frac{W_{max} \times l}{4} = \frac{50 \times 10^3 \times 500}{4} = 6250 \times 10^3 \text{ N-mm}$$

and minimum bending moment,

$$M_{min} = \frac{W_{min} \times l}{4} = \frac{20 \times 10^3 \times 500}{4} = 2500 \times 10^3 \text{ N-mm}$$

$\therefore$  Mean or average bending moment,

$$M_m = \frac{M_{max} + M_{min}}{2} = \frac{6250 \times 10^3 + 2500 \times 10^3}{2} = 4375 \times 10^3 \text{ N-mm}$$

and variable bending moment,

$$M_v = \frac{M_{max} - M_{min}}{2} = \frac{6250 \times 10^3 - 2500 \times 10^3}{2} = 1875 \times 10^3 \text{ N-mm}$$

Section modulus of the bar,

$$Z = \frac{\pi}{32} \times d^3 = 0.0982 d^3 \text{ mm}^3$$

$\therefore$  Mean or average bending stress,

$$\sigma_m = \frac{M_m}{Z} = \frac{4375 \times 10^3}{0.0982 d^3} = \frac{44.5 \times 10^6}{d^3} \text{ N/mm}^2$$

and variable bending stress,

$$\sigma_v = \frac{M_v}{Z} = \frac{1875 \times 10^3}{0.0982 d^3} = \frac{19.1 \times 10^6}{d^3} \text{ N/mm}^2$$

We know that according to Goodman's formula,

$$\begin{aligned} \frac{1}{F.S.} &= \frac{\sigma_m}{\sigma_u} + \frac{\sigma_v \times K_f}{\sigma_e \times K_{sur} \times K_{sz}} \\ \frac{1}{1.5} &= \frac{44.5 \times 10^6}{d^3 \times 650} + \frac{19.1 \times 10^6 \times 1}{d^3 \times 350 \times 0.9 \times 0.85} \quad \dots(\text{Taking } K_f = 1) \\ &= \frac{68 \times 10^3}{d^3} + \frac{71 \times 10^3}{d^3} = \frac{139 \times 10^3}{d^3} \end{aligned}$$

$$\therefore d^3 = 139 \times 10^3 \times 1.5 = 209 \times 10^3 \quad \text{or} \quad d = 59.3 \text{ mm}$$

and according to Soderberg's formula,

$$\begin{aligned} \frac{1}{F.S.} &= \frac{\sigma_m}{\sigma_y} + \frac{\sigma_v \times K_f}{\sigma_e \times K_{sur} \times K_{sz}} \\ \frac{1}{1.5} &= \frac{44.5 \times 10^6}{d^3 \times 500} + \frac{19.1 \times 10^6 \times 1}{d^3 \times 350 \times 0.9 \times 0.85} \quad \dots(\text{Taking } K_f = 1) \\ &= \frac{89 \times 10^3}{d^3} + \frac{71 \times 10^3}{d^3} = \frac{160 \times 10^3}{d^3} \end{aligned}$$

$$\therefore d^3 = 160 \times 10^3 \times 1.5 = 240 \times 10^3 \quad \text{or} \quad d = 62.1 \text{ mm}$$

Taking larger of the two values, we have  $d = 62.1 \text{ mm}$     **Aus.**

### **References:**

1. Machine Design - V. Bandari .
2. Machine Design – R.S. Khurmi
3. Design Data hand Book - S MD Jalaludin.

Problem:

A 50 mm diameter shaft is made from carbon steel having ultimate tensile strength of 630 MPa. It is subjected to a torque which fluctuates between 2000 N-m to – 800 N-m. Using Soderberg method, calculate the factor of safety. Assume suitable values for any other data needed.

Solution. Given:  $d = 50 \text{ mm}$ ;  $\sigma_u = 630 \text{ MPa} = 630 \text{ N/mm}^2$ ;  $T_{max} = 2000 \text{ N-m}$ ;  $T_{min} = -800 \text{ N-m}$   
We know that the mean or average torque,

$$T_m = \frac{T_{max} + T_{min}}{2} = \frac{2000 + (-800)}{2} = 600 \text{ N-m} = 600 \times 10^3 \text{ N-mm}$$

∴ Mean or average shear stress,

$$\tau_m = \frac{16 T_m}{\pi d^3} = \frac{16 \times 600 \times 10^3}{\pi (50)^3} = 24.4 \text{ N/mm}^2 \quad \dots \left( \because T = \frac{\pi}{16} \times \tau \times d^3 \right)$$

Variable torque,

$$T_v = \frac{T_{max} - T_{min}}{2} = \frac{2000 - (-800)}{2} = 1400 \text{ N-m} = 1400 \times 10^3 \text{ N-mm}$$

∴ Variable shear stress,  $\tau_v = \frac{16 T_v}{\pi d^3} = \frac{16 \times 1400 \times 10^3}{\pi (50)^3} = 57 \text{ N/mm}^2$

Since the endurance limit in reversed bending ( $\sigma_e$ ) is taken as one-half the ultimate tensile strength (i.e.  $\sigma_e = 0.5 \sigma_u$ ) and the endurance limit in shear ( $\tau_e$ ) is taken as  $0.55 \sigma_e$ , therefore

$$\begin{aligned} \tau_e &= 0.55 \sigma_e = 0.55 \times 0.5 \sigma_u = 0.275 \sigma_u \\ &= 0.275 \times 630 = 173.25 \text{ N/mm}^2 \end{aligned}$$

Assume the yield stress ( $\sigma_y$ ) for carbon steel in reversed bending as  $510 \text{ N/mm}^2$ , surface finish factor ( $K_{su}$ ) as 0.87, size factor ( $K_{sz}$ ) as 0.85 and fatigue stress concentration factor ( $K_f$ ) as 1.

Since the yield stress in shear ( $\tau_y$ ) for shear loading is taken as one-half the yield stress in reversed bending ( $\sigma_y$ ), therefore

$$\tau_y = 0.5 \sigma_y = 0.5 \times 510 = 255 \text{ N/mm}^2$$

Let  $F.S.$  = Factor of safety.

We know that according to Soderberg's formula,

$$\begin{aligned} \frac{1}{F.S.} &= \frac{\tau_m}{\tau_y} + \frac{\tau_v \times K_f}{\tau_e \times K_{su} \times K_{sz}} = \frac{24.4}{255} + \frac{57 \times 1}{173.25 \times 0.87 \times 0.85} \\ &= 0.096 + 0.445 = 0.541 \end{aligned}$$

∴  $F.S. = 1 / 0.541 = 1.85 \text{ Ans.}$

Problem:

A simply supported beam has a concentrated load at the centre which fluctuates from a value of  $P$  to  $4P$ . The span of the beam is 500 mm and its cross-section is circular with a diameter of 60 mm. Taking for the beam material an ultimate stress of 700 MPa, a yield stress of 500 MPa, endurance limit of 330 MPa for reversed bending, and a factor of safety of 1.3, calculate the maximum value of  $P$ . Take a size factor of 0.85 and a surface finish factor of 0.9.

**Solution.** Given :  $W_{min} = P$  ;  $W_{max} = 4P$  ;  $L = 500$  mm ;  $d = 60$  mm ;  $\sigma_u = 700$  MPa = 700 N/mm<sup>2</sup> ;  $\sigma_y = 500$  MPa = 500 N/mm<sup>2</sup> ;  $\sigma_e = 330$  MPa = 330 N/mm<sup>2</sup> ;  $F.S. = 1.3$  ;  $K_{sz} = 0.85$  ;  $K_{sur} = 0.9$

We know that maximum bending moment,

$$M_{max} = \frac{W_{max} \times L}{4} = \frac{4P \times 500}{4} = 500P \text{ N-mm}$$

and minimum bending moment,

$$M_{min} = \frac{W_{min} \times L}{4} = \frac{P \times 500}{4} = 125P \text{ N mm}$$

∴ Mean or average bending moment,

$$M_m = \frac{M_{max} + M_{min}}{2} = \frac{500P + 125P}{2} = 312.5P \text{ N-mm}$$

and variable bending moment,

$$M_v = \frac{M_{max} - M_{min}}{2} = \frac{500P - 125P}{2} = 187.5P \text{ N-mm}$$

Section modulus, 
$$Z = \frac{\pi}{32} \times d^3 = \frac{\pi}{32} (60)^3 = 21.21 \times 10^3 \text{ mm}^3$$

∴ Mean bending stress,

$$\sigma_m = \frac{M_m}{Z} = \frac{312.5P}{21.21 \times 10^3} = 0.0147P \text{ N/mm}^2$$

and variable bending stress,

$$\sigma_v = \frac{M_v}{Z} = \frac{187.5P}{21.21 \times 10^3} = 0.0088P \text{ N/mm}^2$$

We know that according to Goodman's formula,

$$\frac{1}{F.S.} = \frac{\sigma_m}{\sigma_u} + \frac{\sigma_v \times K_f}{\sigma_e \times K_{sur} \times K_{sz}}$$

$$1.3 = \frac{0.0147P}{700} + \frac{0.0088P \times 1}{330 \times 0.9 \times 0.85} \quad \dots(\text{Taking } K_f = 1)$$

$$= \frac{21P}{10^6} + \frac{34.8P}{10^6} = \frac{55.8P}{10^6}$$

$$\therefore P = \frac{1}{1.3} \times \frac{10^6}{55.8} = 13785 \text{ N} = 13.785 \text{ kN}$$

and according to Soderberg's formula,

$$\frac{1}{F.S.} = \frac{\sigma_m}{\sigma_y} + \frac{\sigma_v \times K_f}{\sigma_e \times K_{sw} \times K_{sz}}$$
$$\frac{1}{1.3} = \frac{0.0147P}{500} + \frac{0.0088P \times 1}{330 \times 0.9 \times 0.85} = \frac{29.4P}{10^6} + \frac{34.8P}{10^6} = \frac{64.2P}{10^6}$$

$$\therefore P = \frac{1}{1.3} \times \frac{10^6}{64.2} = 11982 \text{ N} = 11.982 \text{ kN}$$

From the above, we find that maximum value of  $P = 13.785 \text{ kN}$     **Ans.**

**References:**

1. Machine Design - V.Bandari .
2. Machine Design – R.S. Khurmi
3. Design Data hand Book - S MD Jalaludin.

## UNIT 3

### Riveted Welded and Bolted joints

#### Introduction to Riveted Joints

A rivet is a short cylindrical bar with a head integral to it. The cylindrical portion of the rivet is called **shank** or **body** and lower portion of shank is known as **tail**, as shown in Fig. The rivets are used to make permanent fastening between the plates such as in structural work, ship building, bridges, tanks and boiler shells. The riveted joints are widely used for joining light metals.

The fastenings (i.e. joints) may be classified into the following two groups:

1. Permanent fastenings, and
2. Temporary or detachable fastenings.

The fastenings (i.e. joints) may be classified into the following two groups:

1. Permanent fastenings, and
2. Temporary or detachable fastenings

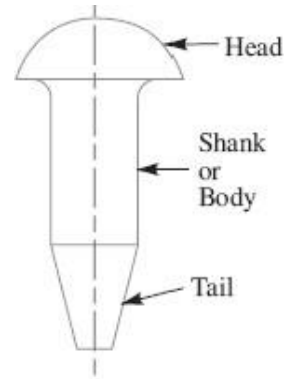

**Fig.** Rivet parts.

The **permanent fastenings** are those fastenings which cannot be disassembled without destroying the connecting components. The examples of permanent fastenings in order of strength are soldered, brazed, welded and riveted joints.

The **temporary or detachable fastenings** are those fastenings which can be disassembled without destroying the connecting components. The examples of temporary fastenings are screwed, keys, cotters, pins and splined joints.

#### Methods of Riveting

The function of rivets in a joint is to make a connection that has strength and tightness. The strength is necessary to prevent failure of the joint. The tightness is necessary in order to contribute to strength and to prevent leakage as in a boiler or in a ship hull.

When two plates are to be fastened together by a rivet as shown in Fig. (a), the holes in the plates are punched and reamed or drilled. Punching is the cheapest method and is used for relatively thin plates and in structural work. Since punching injures the material around the hole, therefore drilling is used in most pressure-vessel work. In structural and pressure vessel riveting, the diameter of the rivet hole is usually 1.5 mm larger than the nominal diameter of the rivet.



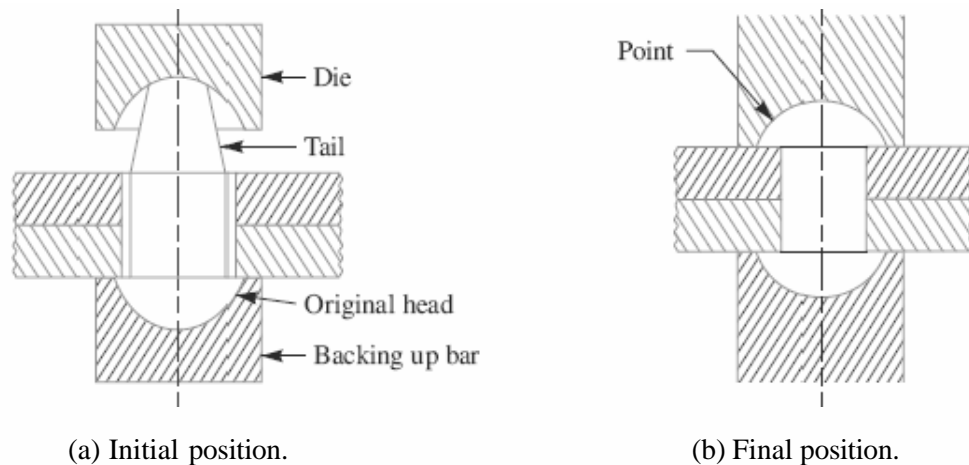

**Fig. Methods of riveting.**

The plates are drilled together and then separated to remove any burrs or chips so as to have a tight flush joint between the plates. A cold rivet or a red hot rivet is introduced into the plates and the **point** (i.e. second head) is then formed. When a cold rivet is used, the process is known as **cold riveting** and when a hot rivet is used, the process is known as **hot riveting**. The cold riveting process is used for structural joints while hot riveting is used to make leak proof joints.

The riveting may be done by hand or by a riveting machine. In hand riveting, the original rivet head is backed up by a hammer or heavy bar and then the die or set, as shown in Fig.(a), is placed against the end to be headed and the blows are applied by a hammer. This causes the shank to expand thus filling the hole and the tail is converted into a **point** as shown in Fig.(b). As the rivet cools, it tends to contract. The lateral contraction will be slight, but there will be a longitudinal tension introduced in the rivet which holds the plates firmly together.

In machine riveting, the die is a part of the hammer which is operated by air, hydraulic or steam pressure.

**Notes:**

1. For steel rivets up to 12 mm diameter, the cold riveting process may be used while for larger diameter rivets, hot riveting process is used.
2. In case of long rivets, only the tail is heated and not the whole shank.

**Types of Rivet Heads**

According to Indian standard specifications, the rivet heads are classified into **the following** three types:

1. Rivet heads for general purposes (below 12 mm diameter) as shown in Fig.

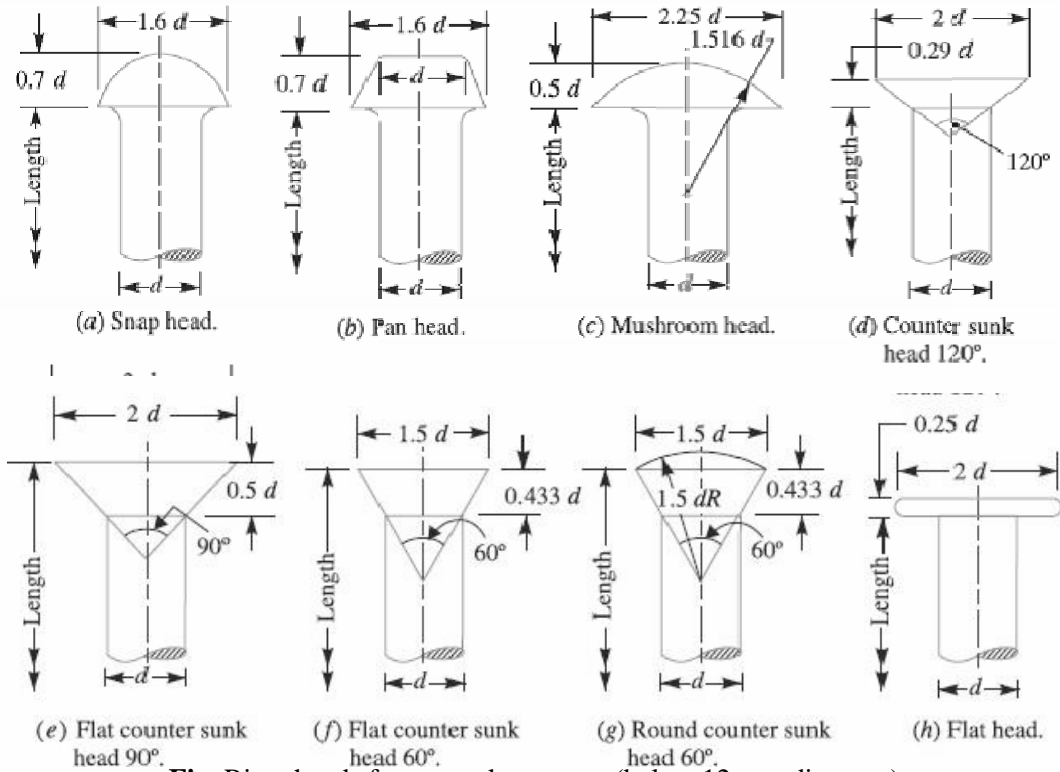

**Fig.** Rivet heads for general purposes (below 12 mm diameter).

2. Rivet heads for general purposes (From 12 mm to 48 mm diameter) as shown in Fig.

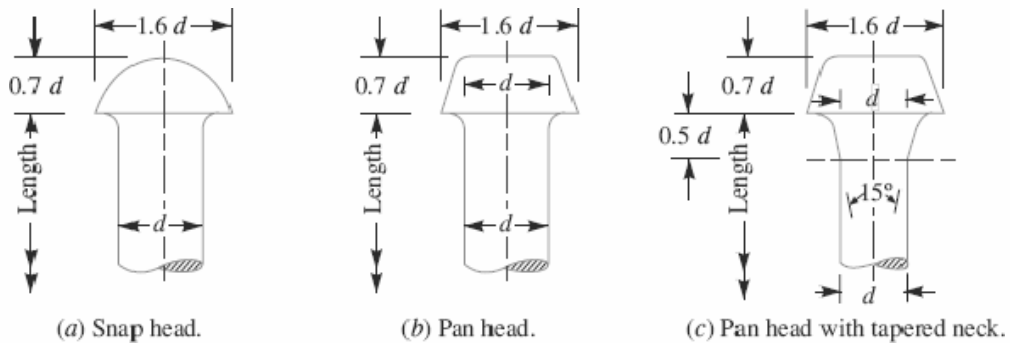

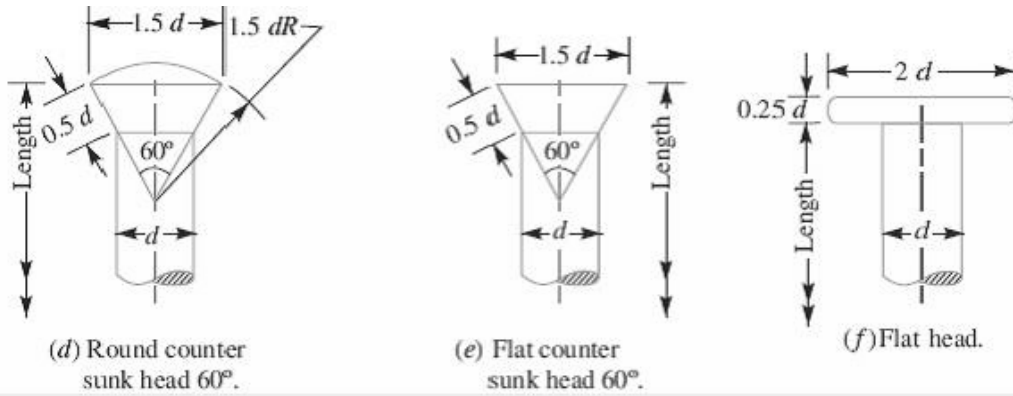

**Fig.** Rivet heads for general purposes (from 12 mm to 48 mm diameter)

3. Rivet heads for boiler work (from 12 mm to 48 mm diameter, as shown in Fig.

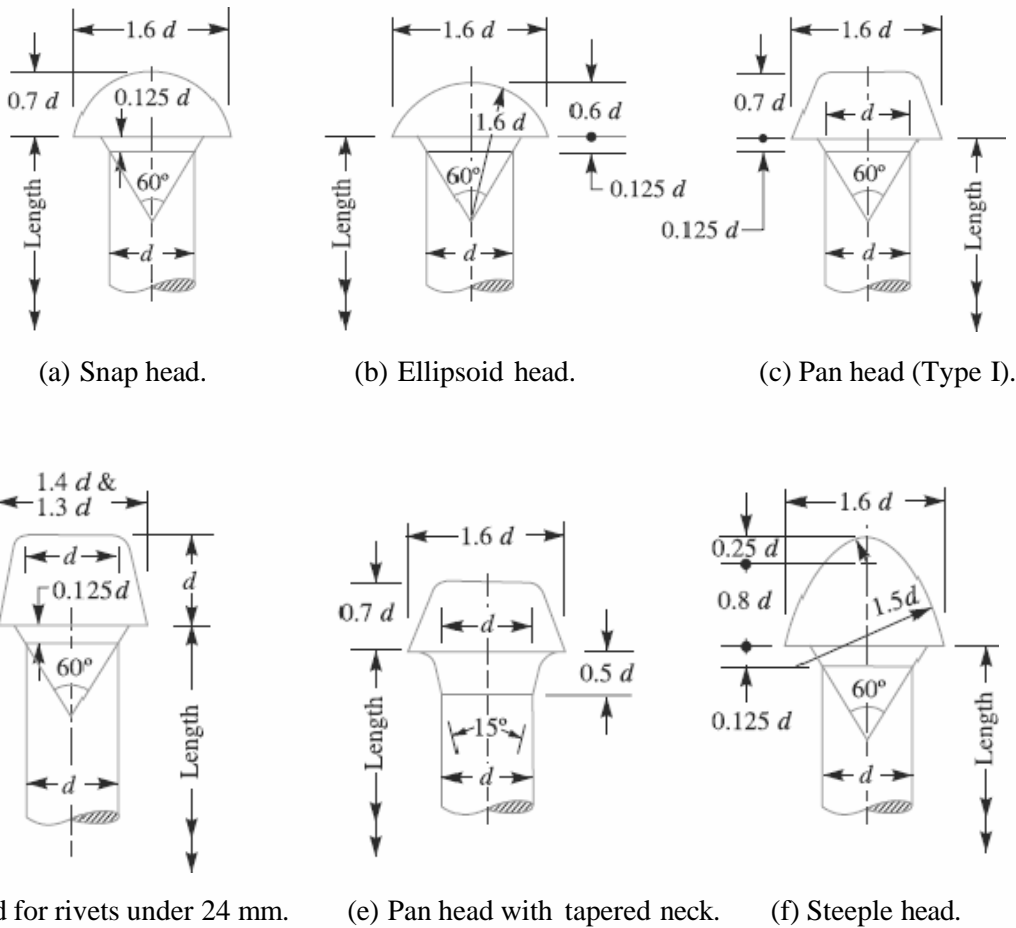

**Types of Riveted Joints**

Following are the two types of riveted joints, depending upon the way in which the plates are connected.

1. Lap joint, and
2. Butt joint.

### **1. Lap Joint**

A lap joint is that in which one plate overlaps the other and the two plates are then riveted together.

### **2. Butt Joint**

A butt joint is that in which the main plates are kept in alignment butting (i.e. touching) each other and a cover plate (i.e. strap) is placed either on one side or on both sides of the main plates. The cover plate is then riveted together with the main plates. Butt joints are of the following two types:

1. Single strap butt joint, and
2. Double strap butt joint.

In a **single strap butt joint**, the edges of the main plates butt against each other and only one cover plate is placed on one side of the main plates and then riveted together. In a **double strap butt joint**, the edges of the main plates butt against each other and two cover plates are placed on both sides of the main plates and then riveted together.

In addition to the above, following are the types of riveted joints depending upon the number of rows of the rivets.

1. Single riveted joint, and
2. Double riveted joint.

A **single riveted joint** is that in which there is a single row of rivets in a lap joint as shown in Fig (a) and there is a single row of rivets on each side in a butt joint as shown in Fig. A **double riveted joint** is that in which there are two rows of rivets in a lap joint as shown in Fig. (b) and (c) and there are two rows of rivets on each side in a butt joint as shown in Fig.

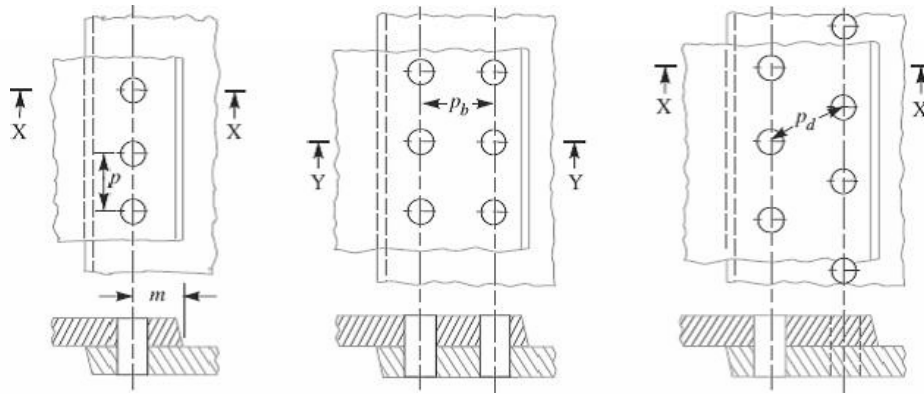

(a) Single riveted lap joint. (b) Double riveted lap joint (Chain riveting). (c) Double riveted lap joint (Zig-zag riveting).

**Fig.** Single and double riveted lap joints.

Similarly the joints may be **triple riveted** or **quadruple riveted**.

**Notes: 1.** when the rivets in the various rows are opposite to each other, as shown in Fig. (b), then the joint is said to be **chain riveted**. On the other hand, if the rivets in the adjacent rows are staggered in such a way that every rivet is in the middle of the two rivets of the opposite row as shown in Fig. (c), then the joint is said to be **zig-zag riveted**.

**2.** Since the plates overlap in lap joints, therefore the force  $P$ ,  $P$  acting on the plates are not in the same straight line but they are at a distance equal to the thickness of the plate. These forces will form a couple which may bend the joint. Hence the lap joints may be used only where small loads are to be transmitted. On the other hand, the forces  $P$ ,  $P$  in a butt joint act in the same straight line, therefore there will be no couple. Hence the butt joints are used where heavy loads are to be transmitted.

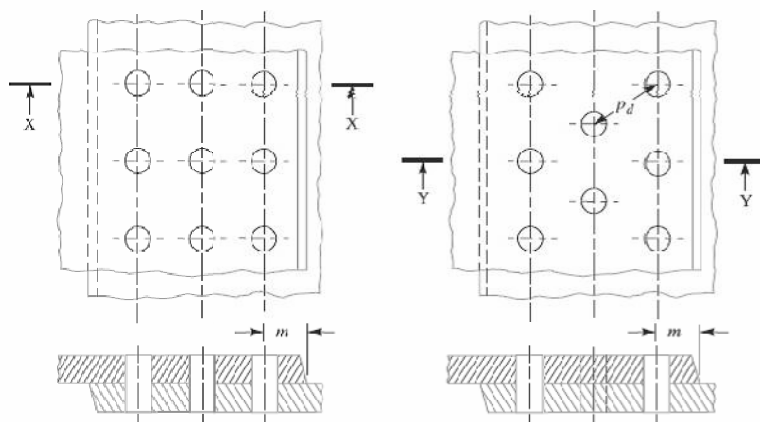

(a) Chain riveting. (b) Zig-zag riveting.

**Fig. 9.7.** Triple riveted lap joint.

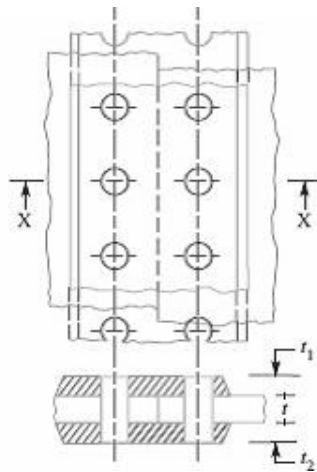

**Fig.** Single riveted double strap butt joint.

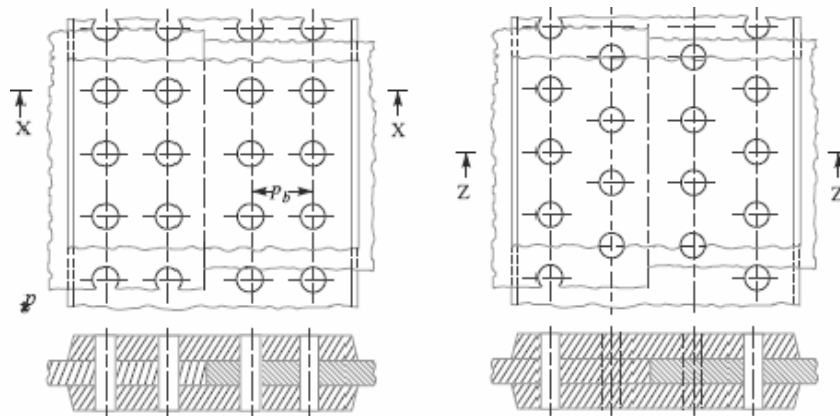

(a) Chain a riveting.

(b) Zig-zag riveting

**Fig.** Double riveted double strap (equal) butt joints.

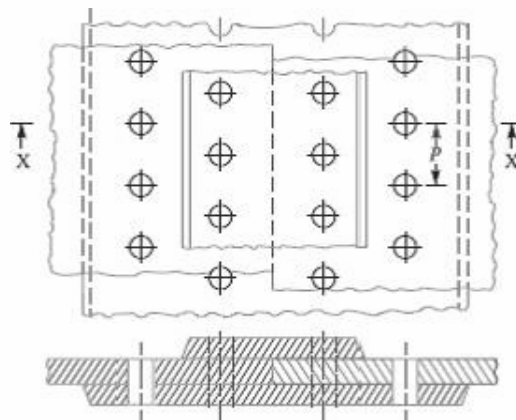

**Fig.** Double riveted double strap (unequal) butt joint with zig-zag riveting.

**References:**

1. Machine Design - V.Bandari .
2. Machine Design – R.S. Khurmi
3. Design Data hand Book - S MD Jalaludin.

### Important Terms Used in Riveted Joints

The following terms in connection with the riveted joints are important from the subject point of view:

- 1. Pitch.** It is the distance from the centre of one rivet to the centre of the next rivet measured parallel to the seam as shown in Fig.1 It is usually denoted by  $p$ .
- 2. Back pitch.** It is the perpendicular distance between the centre lines of the successive rows as shown in Fig.1. It is usually denoted by  $p_b$ .
- 3. Diagonal pitch.** It is the distance between the centers of the rivets in adjacent rows of zigzag riveted joint as shown in Fig. It is usually denoted by  $p_d$ .
- 4. Margin or marginal pitch.** It is the distance between the centres of rivet hole to the nearest edge of the plate as shown in Fig. 9.6. It is usually denoted by  $m$ .

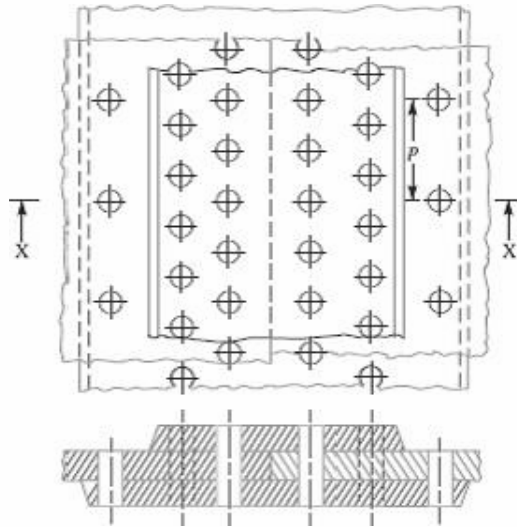

**Fig.1.** Triple riveted double strap (unequal) butt joint.

### Caulking and Fullering

In order to make the joints leak proof or fluid tight in pressure vessels like steam boilers, air receivers and tanks etc. a process known as **caulking** is employed. In this process, a narrow blunt tool called caulking tool, about 5 mm thick and 38 mm in breadth, is used. The edge of the tool is ground to an angle of  $80^\circ$ . The tool is moved after each blow along the edge of the plate, which is planed to a level of  $75^\circ$  to  $80^\circ$  to facilitate the forcing down of edge. It is seen that the tool burrs down the plate at A in Fig.2 (a) forming a metal to metal joint. In actual practice, both the edges at A and B are caulked. The head of the rivets as shown at C are also



turned down with a caulking tool to make a joint steam tight. A great care is taken to prevent injury to the plate below the tool.

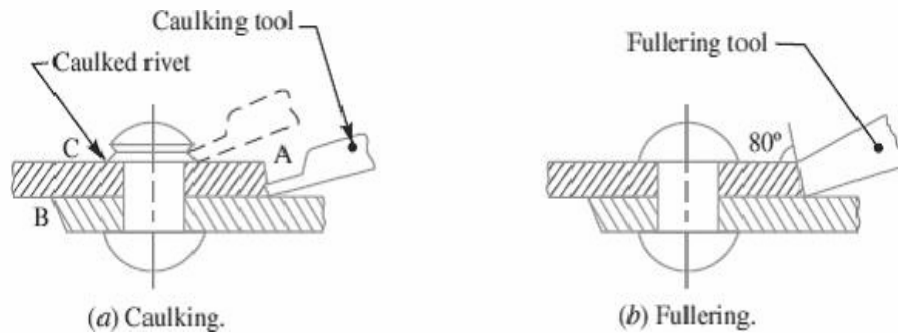

**Fig.2.** Caulking and fullering.

A more satisfactory way of making the joints staunch is known as **fullering** which has largely superseded caulking. In this case, a fullering tool with a thickness at the end equal to that of the plate is used in such a way that the greatest pressure due to the blows occur near the joint, giving a clean finish, with less risk of damaging the plate. A fullering process is shown in Fig. (b).

**Failures of a Riveted Joint**

A riveted joint may fail in the following ways:

- 1. Tearing of the plate at an edge.** A joint may fail due to tearing of the plate at an edge as shown in Fig.3. This can be avoided by keeping the margin,  $m = 1.5d$ , where  $d$  is the diameter of the rivet hole.
- 2. Tearing of the plate across a row of rivets.** Due to the tensile stresses in the main plates, the main plate or cover plates may tear off across a row of rivets as shown in Fig. In such cases, we consider only one pitch length of the plate, since every rivet is responsible for that much length of the plate only.

The resistance offered by the plate against tearing is known as **tearing resistance** or **tearing strength** or **tearing value** of the plate.

Let  $p$  = Pitch of the rivets,

$d$  = Diameter of the rivet hole,

$t$  = Thickness of the plate, and

$\sigma_t$  = Permissible tensile stress for the plate material.

We know that tearing area per pitch length,

$$A_t = (p-d)t$$

∴ Tearing resistance or pull required to tear off the plate per pitch length,

$$P_t = A_t \cdot \sigma_t = (p-d)t \cdot \sigma_t$$

When the tearing resistance ( $P_t$ ) is greater than the applied load ( $P$ ) per pitch length, then this type of failure will not occur.

**3. Shearing of the rivets.** The plates which are connected by the rivets exert tensile stress on the rivets, and if the rivets are unable to resist the stress, they are sheared off as shown in Fig. 5.

It may be noted that the rivets are in single shear in a lap joint and in a single cover butt joint, as shown in Fig. But the rivets are in double shear in a double cover butt joint as shown in Fig. The resistance offered by a rivet to be sheared off is known as **shearing resistance** or **shearing strength** or **shearing value** of the rivet.

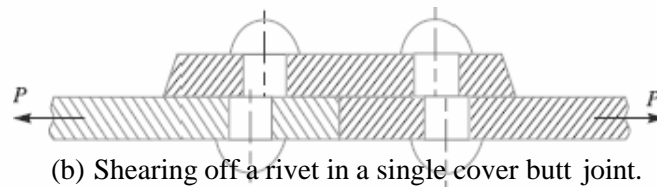
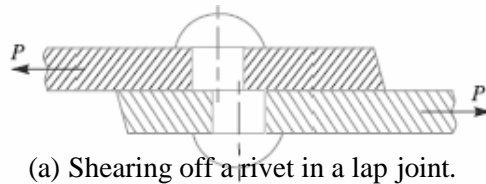

**Fig. 5.** Shearing of rivets.

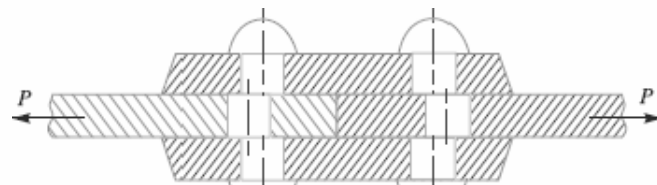

Let  $d$  = Diameter of the rivet hole,

$\tau$  = Safe permissible shear stress for the rivet material, and

$n$  = Number of rivets per pitch length.

We know that shearing area,

$$A_s = \frac{\pi}{4} d^2 \quad \dots (\text{In single shear})$$

$$= 2 \times \frac{\pi}{4} d^2 \quad \dots (\text{Theoretically, in double shear})$$

$$= 1.875 \times \frac{\pi}{4} d^2 \quad \dots (\text{In double shear, according to Indian Boiler Regulations})$$

□

∴ Shearing resistance or pull required to shear off the rivet per pitch length,

$$P_s = n \times \frac{\pi}{4} d^2 \times \tau \quad \dots (\text{In single shear})$$

$$= n \times 2 \times \frac{\pi}{4} d^2 \times \tau \quad \dots (\text{Theoretically, in double shear})$$

As we discussed earlier, when the shearing takes place at one cross-section of the rivet, then the rivets are said to be in **single shear**. Similarly, when the shearing takes place at two cross-sections of the rivet, then the rivets are said to be in **double shear**.

$$= n \times 1.875 \times \frac{\pi}{4} d^2 \times \tau \quad \dots (\text{In double shear, according to Indian Boiler Regulations})$$

When the shearing resistance ( $P_s$ ) is greater than the applied load ( $P$ ) per pitch length, then this type of failure will occur.

**4. Crushing of the plate or rivets.** Sometimes, the rivets do not actually shear off under the tensile stress, but are crushed as shown in Fig. Due to this, the rivet hole becomes of an oval shape and hence the joint becomes loose. The failure of rivets in such a manner is also known as **bearing failure**. The area which resists this action is the projected area of the hole or rivet on diametric plane.

The resistance offered by a rivet to be crushed is known as **crushing resistance** or **crushing strength** or **bearing value** of the rivet.

Let  $d$  = Diameter of the rivet hole,

$t$  = Thickness of the plate,

$\sigma_c$  = Safe permissible crushing stress for the rivet or plate material, and

$n$  = Number of rivets per pitch length under crushing.

We know that crushing area per rivet (i.e. projected area per rivet),

$$A_c = d \cdot t$$

$\therefore$  Total crushing area =  $n \cdot d \cdot t$

And crushing resistance or pull required to crush the rivet per pitch length,

$$P_c = n \cdot d \cdot t \cdot \sigma_c$$

When the crushing resistance ( $P_c$ ) is greater than the applied load ( $P$ ) per pitch length, then this type of failure will occur.

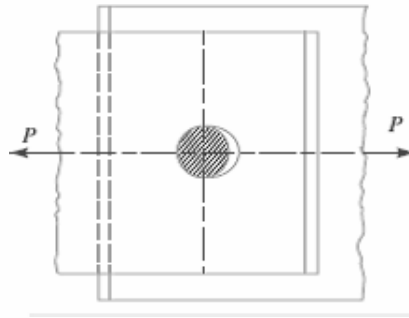

**Fig. 7.** Crushing of a rivet.

### **Strength of a Riveted Joint**

The strength of a joint may be defined as the maximum force, which it can transmit, without causing it to fail. We have seen that  $P_t$ ,  $P_s$  and  $P_c$  are the pulls required to tear off the plate, shearing off the rivet and crushing off the rivet. A little consideration will show that if we go on increasing the pull on a riveted joint, it will fail when the least of these three pulls is reached, because a higher value of the other pulls will never reach since the joint has failed, either by tearing off the plate, shearing off the rivet or crushing off the rivet.

If the joint is **continuous** as in case of boilers, the strength is calculated **per pitch length**. But if the joint is **small**, the strength is calculated for the **whole length** of the plate.

### **Efficiency of a Riveted Joint**

The efficiency of a riveted joint is defined as the ratio of the strength of riveted joint to the strength of the un-riveted or solid plate. We have already discussed that strength of the riveted joint

$$= \text{Least of } P_t, P_s \text{ and } P_c$$

Strength of the un-riveted or solid plate per pitch length,

$$P = p \cdot t \cdot \sigma_t$$

∴ Efficiency of the riveted joint,

$$\eta = \frac{\text{Least of } P_t, P_s \text{ and } P_c}{p \times t \times \sigma_t}$$

Where p = Pitch of the rivets,

t = Thickness of the plate, and

$\sigma_t$  = Permissible tensile stress of the plate material.

**References:**

1. Machine Design - V.Bandari .
2. Machine Design – R.S. Khurmi
3. Design Data hand Book - S MD Jalaludin.

**Problems on design of riveted joints**

Problem:

A double riveted lap joint is made between 15 mm thick plates. The rivet diameter and pitch are 25 mm and 75 mm respectively. If the ultimate stresses are 400 MPa in tension, 320 MPa in shear and 640 MPa in crushing, find the minimum force per pitch which will rupture the joint. If the above joint is subjected to a load such that the factor of safety is 4, find out the actual stresses developed in the plates and the rivets.

**Solution.** Given :  $t = 15 \text{ mm}$  ;  $d = 25 \text{ mm}$  ;  $p = 75 \text{ mm}$  ;  $\sigma_{tu} = 400 \text{ MPa} = 400 \text{ N/mm}^2$  ;  $\tau_u = 320 \text{ MPa} = 320 \text{ N/mm}^2$  ;  $\sigma_{cu} = 640 \text{ MPa} = 640 \text{ N/mm}^2$

*Minimum force per pitch which will rupture the joint*

Since the ultimate stresses are given, therefore we shall find the ultimate values of the resistances of the joint. We know that ultimate tearing resistance of the plate per pitch,

$$P_{tu} = (p - d)t \times \sigma_{tu} = (75 - 25)15 \times 400 = 300\,000 \text{ N}$$

Ultimate shearing resistance of the rivets per pitch,

$$P_{su} = n \times \frac{\pi}{4} \times d^2 \times \tau_u = 2 \times \frac{\pi}{4} (25)^2 320 = 314\,200 \text{ N} \quad \dots (\because n = 2)$$

and ultimate crushing resistance of the rivets per pitch,

$$P_{cu} = n \times d \times t \times \sigma_{cu} = 2 \times 25 \times 15 \times 640 = 480\,000 \text{ N}$$

From above we see that the minimum force per pitch which will rupture the joint is 300 000 N or 300 kN. **Ans.**

*Actual stresses produced in the plates and rivets*

Since the factor of safety is 4, therefore safe load per pitch length of the joint  
 $= 300\,000 / 4 = 75\,000 \text{ N}$

Let  $\sigma_{ta}$ ,  $\tau_a$  and  $\sigma_{ca}$  be the actual tearing, shearing and crushing stresses produced with a safe load of 75 000 N in tearing, shearing and crushing.

We know that actual tearing resistance of the plates ( $P_{ta}$ ),

$$75\,000 = (p - d)t \times \sigma_{ta} = (75 - 25)15 \times \sigma_{ta} = 750 \sigma_{ta}$$

$$\therefore \sigma_{ta} = 75\,000 / 750 = 100 \text{ N/mm}^2 = 100 \text{ MPa} \quad \text{Ans.}$$

Actual shearing resistance of the rivets ( $P_{sa}$ ),

$$75\,000 = n \times \frac{\pi}{4} \times d^2 \times \tau_a = 2 \times \frac{\pi}{4} (25)^2 \tau_a = 982 \tau_a$$

$$\therefore \tau_a = 75000 / 982 = 76.4 \text{ N/mm}^2 = 76.4 \text{ MPa} \quad \text{Ans.}$$

and actual crushing resistance of the rivets ( $P_{ca}$ ),

$$75\,000 = n \times d \times t \times \sigma_{ca} = 2 \times 25 \times 15 \times \sigma_{ca} = 750 \sigma_{ca}$$

$$\therefore \sigma_{ca} = 75000 / 750 = 100 \text{ N/mm}^2 = 100 \text{ MPa} \quad \text{Ans.}$$

Problem

Find the efficiency of the following riveted joints:

1. Single riveted lap joint of 6 mm plates with 20 mm diameter rivets having a pitch of 50 mm.
  2. Double riveted lap joint of 6 mm plates with 20 mm diameter rivets having a pitch of 65 mm.
- Assume Permissible tensile stress in plate = 120 MPa Permissible shearing stress in rivets = 90 MPa Permissible crushing stress in rivets = 180 MPa.

**Solution.** Given :  $t = 6 \text{ mm}$  ;  $d = 20 \text{ mm}$  ;  $\sigma_t = 120 \text{ MPa} = 120 \text{ N/mm}^2$  ;  $\tau = 90 \text{ MPa} = 90 \text{ N/mm}^2$  ;  $\sigma_c = 180 \text{ MPa} = 180 \text{ N/mm}^2$

**1. Efficiency of the first joint**

Pitch,  $p = 50 \text{ mm}$  ... (Given)

First of all, let us find the tearing resistance of the plate, shearing and crushing resistances of the rivets.

**(i) Tearing resistance of the plate**

We know that the tearing resistance of the plate per pitch length,

$$P_t = (p - d) t \times \sigma_t = (50 - 20) 6 \times 120 = 21\,600 \text{ N}$$

**(ii) Shearing resistance of the rivet**

Since the joint is a single riveted lap joint, therefore the strength of one rivet in single shear is taken. We know that shearing resistance of one rivet,

$$P_s = \frac{\pi}{4} \times d^2 \times \tau = \frac{\pi}{4} (20)^2 90 = 28\,278 \text{ N}$$

**(iii) Crushing resistance of the rivet**

Since the joint is a single riveted, therefore strength of one rivet is taken. We know that crushing resistance of one rivet,

$$P_c = d \times t \times \sigma_c = 20 \times 6 \times 180 = 21\,600 \text{ N}$$

$\therefore$  Strength of the joint

$$= \text{Least of } P_t, P_s \text{ and } P_c = 21\,600 \text{ N}$$

We know that strength of the unriveted or solid plate,

$$P = p \times t \times \sigma_t = 50 \times 6 \times 120 = 36\,000 \text{ N}$$

$\therefore$  Efficiency of the joint,

$$\eta = \frac{\text{Least of } P_t, P_s \text{ and } P_c}{P} = \frac{21\,600}{36\,000} = 0.60 \text{ or } 60\% \text{ Ans.}$$

**2. Efficiency of the second joint**

Pitch,  $p = 65 \text{ mm}$  ... (Given)

**(i) Tearing resistance of the plate,**

We know that the tearing resistance of the plate per pitch length,

$$P_t = (p - d) t \times \sigma_t = (65 - 20) 6 \times 120 = 32\,400 \text{ N}$$

(ii) *Shearing resistance of the rivets*

Since the joint is double riveted lap joint, therefore strength of two rivets in single shear is taken. We know that shearing resistance of the rivets,

$$P_s = n \times \frac{\pi}{4} \times d^2 \times \tau = 2 \times \frac{\pi}{4} (20)^2 90 = 56\,556 \text{ N}$$

(iii) *Crushing resistance of the rivet*

Since the joint is double riveted, therefore strength of two rivets is taken. We know that crushing resistance of rivets,

$$P_c = n \times d \times t \times \sigma_c = 2 \times 20 \times 6 \times 180 = 43\,200 \text{ N}$$

∴ Strength of the joint

$$= \text{Least of } P_t, P_s \text{ and } P_c = 32\,400 \text{ N}$$

We know that the strength of the unriveted or solid plate,

$$P = p \times t \times \sigma_t = 65 \times 6 \times 120 = 46\,800 \text{ N}$$

∴ Efficiency of the joint,

$$\eta = \frac{\text{Least of } P_t, P_s \text{ and } P_c}{P} = \frac{32\,400}{46\,800} = 0.692 \text{ or } 69.2\% \quad \text{Ans.}$$

**References:**

1. Machine Design - V.Bandari.
2. Machine Design – R.S. Khurmi
3. Design Data hand Book - S MD Jalaludin.



Design of boiler joints according to IBR

### **Design of Boiler Joints**

The boiler has a longitudinal joint as well as circumferential joint. The **longitudinal joint** is used to join the ends of the plate to get the required diameter of a boiler. For this purpose, a butt joint with two cover plates is used. The **circumferential joint** is used to get the required length of the boiler. For this purpose, a lap joint with one ring overlapping the other alternately is used. Since a boiler is made up of number of rings, therefore the longitudinal joints are staggered for convenience of connecting rings at places where both longitudinal and circumferential joints occur.

### **Design of Longitudinal Butt Joint for a Boiler**

According to Indian Boiler Regulations (I.B.R), the following procedure should be adopted for the design of longitudinal butt joint for a boiler.

**1. Thickness of boiler shell.** First of all, the thickness of the boiler shell is determined by using the thin cylindrical formula, *i.e.*

$$t = \frac{P.D}{2\sigma_t \eta_l} + 1 \text{ mm as corrosion allowance}$$

Where  $t$  = Thickness of the boiler shell,

$P$  = Steam pressure in boiler,

$D$  = Internal diameter of boiler shell,

$\sigma_t$  = Permissible tensile stress, and

$\eta_l$  = Efficiency of the longitudinal joint.

The following points may be noted:

(a) The thickness of the boiler shell should not be less than 7 mm.

(b) The efficiency of the joint may be taken from the following table.

Indian Boiler Regulations (I.B.R.) allows a maximum efficiency of 85% for the best joint.

(c) According to I.B.R., the factor of safety should not be less than 4.

**2. Diameter of rivets.** After finding out the thickness of the boiler shell ( $t$ ), the diameter of the rivet hole ( $d$ ) may be determined by using Unwin's empirical formula,

*i.e.*  $d = 6 t$  (when  $t$  is greater than 8 mm)

But if the thickness of plate is less than 8 mm, then the diameter of the rivet hole may be calculated by equating the shearing resistance of the rivets to crushing resistance. In no case,

the diameter of rivet hole should not be less than the thickness of the plate, because there will be danger of punch crushing.

**3. Pitch of rivets.** The pitch of the rivets is obtained by equating the tearing resistance of the plate to the shearing resistance of the rivets. It may be noted that (a) The pitch of the rivets should not be less than  $2d$ , which is necessary for the formation of head.

(b) The maximum value of the pitch of rivets for a longitudinal joint of a boiler as per I.B.R. is  $p_{max} = C \times t + 41.28$  mm where  $t$  = Thickness of the shell plate in mm, and  $C$  = Constant. The value of the constant  $C$  may be taken from DDB. If the pitch of rivets as obtained by equating the tearing resistance to the shearing resistance is more than  $p_{max}$ , then the value of  $p_{max}$  is taken.

**4. Distance between the rows of rivets.** The distance between the rows of rivets as specified by Indian Boiler Regulations is as follows:

(a) For equal number of rivets in more than one row for lap joint or butt joint, the distance between the rows of rivets ( $p_b$ ) should not be less than  $0.33 p + 0.67 d$ , for zig-zig riveting, and  $2 d$ , for chain riveting.

(b) For joints in which the number of rivets in outer rows is **half** the number of rivets in inner rows and if the inner rows are chain riveted, the distance between the outer rows and the next rows should not be less than  $0.33 p + 0.67 d$  or  $2 d$ , whichever is greater. The distance between the rows in which there are full number of rivets shall not be less than  $2d$ .

(c) For joints in which the number of rivets in outer rows is **half** the number of rivets in inner rows and if the inner rows are zig-zig riveted, the distance between the outer rows and the next rows shall not be less than  $0.2 p + 1.15 d$ . The distance between the rows in which there are full number of rivets (zig-zag) shall not be less than  $0.165 p + 0.67 d$ .

**Note :** In the above discussion,  $p$  is the pitch of the rivets in the outer rows.

**5. Thickness of butt strap.** According to I.B.R., the thicknesses for butt strap ( $t_1$ ) are as given below:

(a) The thickness of butt strap, in no case, shall be less than 10 mm.

(b)  $t_1 = 1.125 t$ , for ordinary (chain riveting) single butt strap.

$$t_1 = 1.125 t \left( \frac{p - d}{p - 2d} \right)$$

For single butt straps, every alternate rivet in outer rows being omitted.

$t_1 = 0.625 t$ , for double butt-straps of equal width having ordinary riveting (chain riveting).

$$t_1 = 0.625 t \left( \frac{p - d}{p - 2d} \right)$$

For double butt straps of equal width having every alternate rivet in the outer rows being omitted.

(c) For unequal width of butt straps, the thicknesses of butt strap are

$t_1 = 0.75 t$ , for wide strap on the inside, and

$t_1 = 0.625 t$ , for narrow strap on the outside.

**6. Margin.** The margin ( $m$ ) is taken as  $1.5 d$ .

**Note:** The above procedure may also be applied to ordinary riveted joints.

**References:**

1. Machine Design - V.Bandari .
2. Machine Design – R.S. Khurmi
3. Design Data hand Book - S MD Jalaludin.

**Eccentric Loaded Riveted Joint**

When the line of action of the load does not pass through the centroid of the rivet system and thus all rivets are not equally loaded, then the joint is said to be an *eccentric loaded riveted joint*, as shown in Fig. 1(a). The eccentric loading results in secondary shear caused by the tendency of force to twist the joint about the centre of gravity in addition to direct shear or primary shear.

Let  $P =$  Eccentric load on the joint, and

$e =$  Eccentricity of the load *i.e.* the distance between the line of action of the load and the centroid of the rivet system *i.e.*  $G$ .

The following procedure is adopted for the design of an eccentrically loaded riveted joint.

Note: This picture is given as additional information and is not a direct example of the current chapter.

1. First of all, find the centre of gravity  $G$  of the rivet system.

Let  $A =$  Cross-sectional area of each rivet,

$x_1, x_2, x_3$  etc. = Distances of rivets from  $OY$ , and

$y_1, y_2, y_3$  etc. = Distances of rivets from  $OX$ .

We know that 
$$\bar{x} = \frac{A_1x_1 + A_2x_2 + A_3x_3 + \dots}{A_1 + A_2 + A_3 + \dots} = \frac{Ax_1 + Ax_2 + Ax_3 + \dots}{n.A}$$

$$= \frac{x_1 + x_2 + x_3 + \dots}{n} \quad \dots(\text{where } n = \text{Number of rivets})$$

Similarly, 
$$\bar{y} = \frac{y_1 + y_2 + y_3 + \dots}{n}$$

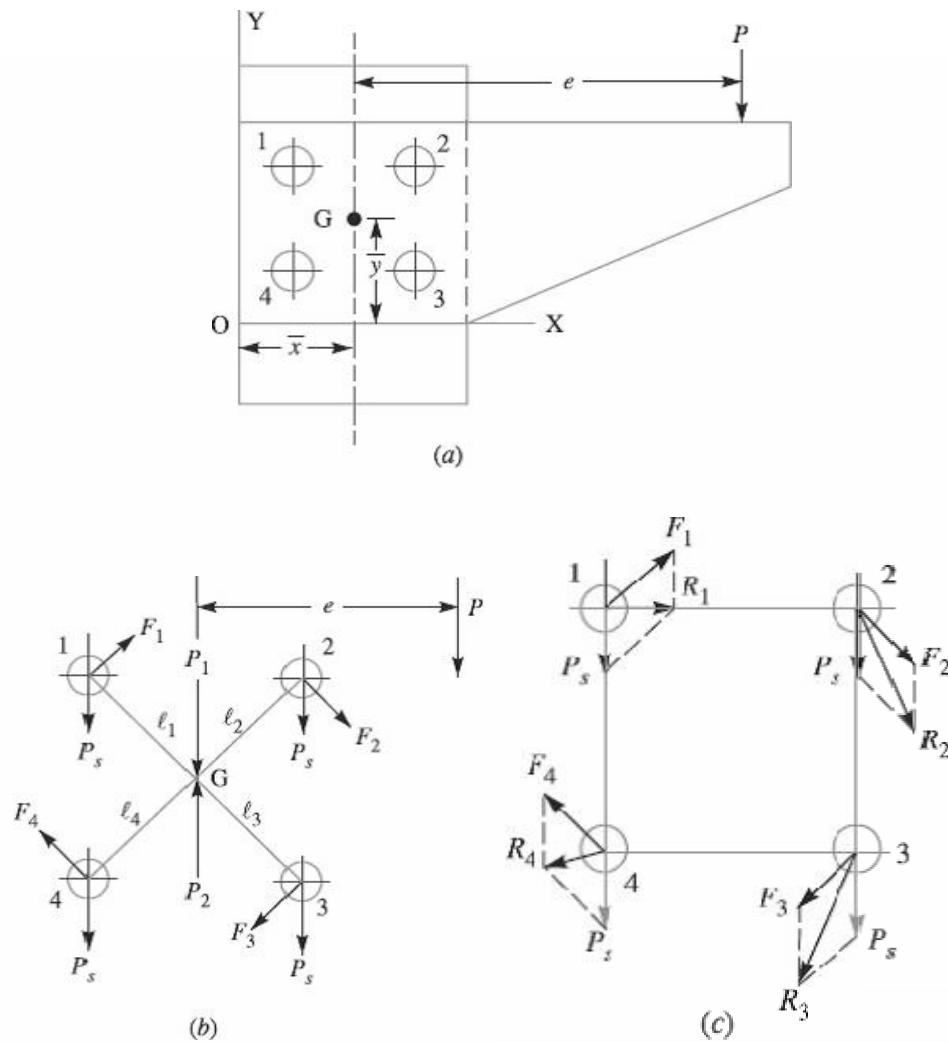

Fig. 1. Eccentric loaded riveted joint.

2. Introduce two forces  $P_1$  and  $P_2$  at the centre of gravity 'G' of the rivet system. These forces are equal and opposite to  $P$  as shown in Fig.(b).

3. Assuming that all the rivets are of the same size, the effect of  $P_1 = P$  is to produce direct shear load on each rivet of equal magnitude. Therefore, direct shear load on each rivet,

$$P_s = \frac{P}{n}, \text{ acting parallel to the load } P,$$

4. The effect of  $P_2 = P$  is to produce a turning moment of magnitude  $P \times e$  which tends to rotate the joint about the centre of gravity 'G' of the rivet system in a clockwise direction. Due to the turning moment, secondary shear load on each rivet is produced. In order to find the secondary shear load, the following two assumptions are made:

(a) The secondary shear load is proportional to the radial distance of the rivet under consideration from the centre of gravity of the rivet system.

(b) The direction of secondary shear load is perpendicular to the line joining the centre of the rivet to the centre of gravity of the rivet system..

Let  $F_1, F_2, F_3 \dots$  = Secondary shear loads on the rivets 1, 2, 3...etc.

$r_1, r_2, r_3 \dots$  = Radial distance of the rivets 1, 2, 3 ...etc. from the centre of gravity 'G' of the rivet system.

$\therefore$  From assumption (a),  $F_1 \propto r_1$ ;  $F_2 \propto r_2$  and so on

or 
$$\frac{F_1}{r_1} = \frac{F_2}{r_2} = \frac{F_3}{r_3} = \dots$$

$$F_2 = F_1 \times \frac{r_2}{r_1}, \text{ and } F_3 = F_1 \times \frac{r_3}{r_1}$$

We know that the sum of the external turning moment due to the eccentric load and of internal resisting moment of the rivets must be equal to zero.

$$\begin{aligned} \therefore P \cdot e &= F_1 r_1 + F_2 r_2 + F_3 r_3 + \dots \\ &= F_1 r_1 + F_1 \times \frac{r_2}{r_1} r_2 + F_1 \times \frac{r_3}{r_1} r_3 + \dots \\ &= \frac{F_1}{r_1} \left[ (r_1)^2 + (r_2)^2 + (r_3)^2 + \dots \right] \end{aligned}$$

From the above expression, the value of  $F_1$  may be calculated and hence  $F_2$  and  $F_3$  etc. are known. The direction of these forces are at right angles to the lines joining the centre of rivet to the centre of gravity of the rivet system, as shown in Fig. 1(b), and should produce the moment in the same direction (i.e. clockwise or anticlockwise) about the centre of gravity, as the turning moment ( $P \times e$ ).

5. The primary (or direct) and secondary shear load may be added vectorially to determine the resultant shear load (R) on each rivet as shown in Fig.1 (c). It may also be obtained by using the relation

$$R = \sqrt{\left(\frac{P}{s}\right)^2 + \frac{F}{2} + 2Ps \times F \times \cos \theta}$$

Where  $\theta$  = Angle between the primary or direct shear load ( $P_s$ )

And secondary shear load ( $F$ ).

When the secondary shear load on each rivet is equal, then the heavily loaded rivet will be one in which the included angle between the direct shear load and secondary shear load is minimum. The maximum loaded rivet becomes the critical one for determining the strength of the riveted joint. Knowing the permissible shear stress ( $\tau$ ), the diameter of the rivet hole may be obtained by using the relation,

$$\text{Maximum resultant shear load (R)} = \frac{\pi}{4} \times d^2 \times \tau$$

From DDB, the standard diameter of the rivet hole ( $d$ ) and the rivet diameter may be specified

- Notes :**
1. In the solution of a problem, the primary and shear loads may be laid off approximately to scale and generally the rivet having the maximum resultant shear load will be apparent by inspection. The values of the load for that rivet may then be calculated.
  2. When the thickness of the plate is given, then the diameter of the rivet hole may be checked against crushing.
  3. When the eccentric load  $P$  is inclined at some angle, then the same procedure as discussed above may be followed to find the size of rivet.

Problem: An eccentrically loaded lap riveted joint is to be designed for a steel bracket, as shown in Fig. 2. The bracket plate is 25 mm thick. All rivets are to be of the same size. Load on the bracket,  $P = 50$  kN ; rivet spacing,  $C = 100$  mm; load arm,  $e = 400$  mm. Permissible shear stress is 65 MPa and crushing stress is 120 MPa. Determine the size of the rivets to be used for the joint.

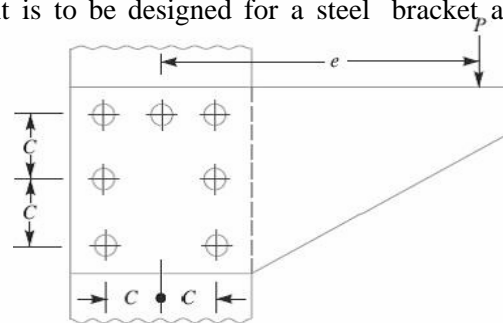

**Solution.** Given:  $t = 25 \text{ mm}$  ;  $P = 50 \text{ kN} = 50 \times 10^3 \text{ N}$  ;  $e = 400 \text{ mm}$  ;  $n = 7$  ;  $\tau = 65 \text{ MPa} = 65 \text{ N/mm}^2$  ;  $\sigma_c = 120 \text{ MPa} = 120 \text{ N/mm}^2$ .

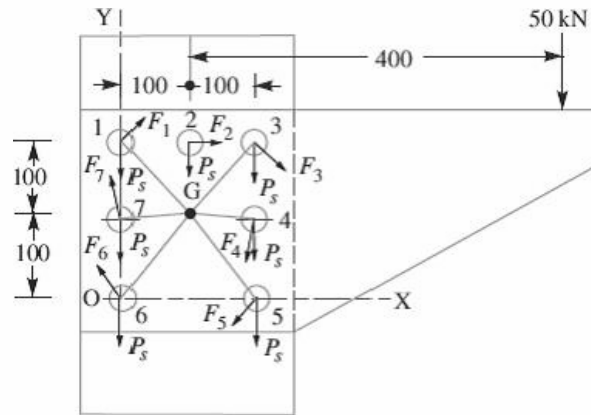

Fig.2

First of all, let us find the centre of gravity ( $G$ ) of the rivet system.

Let  $\bar{x}$  = Distance of centre of gravity from  $OY$ ,

$\bar{y}$  = Distance of centre of gravity from  $OX$ ,

$x_1, x_2, x_3, \dots$  = Distances of centre of gravity of each rivet from  $OY$ , and

$y_1, y_2, y_3, \dots$  = Distances of centre of gravity of each rivet from  $OX$ .

We know that

$$\begin{aligned} \bar{x} &= \frac{x_1 + x_2 + x_3 + x_4 + x_5 + x_6 + x_7}{n} \\ &= \frac{100 + 200 + 200 + 200}{7} = 100 \text{ mm} \quad \dots(\because x_1 = x_6 = x_7 = 0) \end{aligned}$$

$$\begin{aligned} \bar{y} &= \frac{y_1 + y_2 + y_3 + y_4 + y_5 + y_6 + y_7}{n} \\ &= \frac{200 + 200 + 200 + 100 + 100}{7} = 114.3 \text{ mm} \quad \dots(\because y_5 = y_6 = 0) \end{aligned}$$

The centre of gravity ( $G$ ) of the rivet system lies at a distance of 100 mm from  $OY$  and 114.3 mm from  $OX$ , as shown in Fig. 2.

We know that direct shear load on each rivet,



$$P_s = \frac{P}{n} = \frac{50 \times 10^3}{7} = 7143 \text{ N}$$

The direct shear load acts parallel to the direction of load  $P$  i.e. vertically downward as shown in Fig. 2. Turning moment produced by the load  $P$  due to eccentricity ( $e$ )

$$= P \times e = 50 \times 10^3 \times 400 = 20 \times 10^6 \text{ N-mm}$$

This turning moment is resisted by seven rivets as shown in Fig.2.

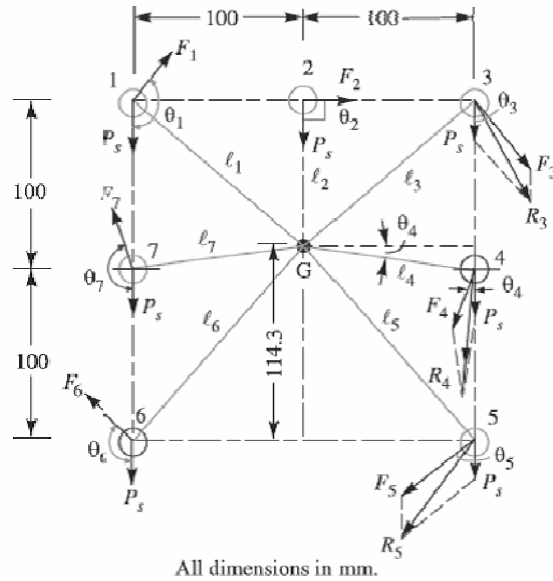

Fig. 3

Let  $F_1, F_2, F_3, F_4, F_5, F_6$  and  $F_7$  be the secondary shear load on the rivets 1, 2, 3, 4, 5, 6 and 7 placed at distances  $l_1, l_2, l_3, l_4, l_5, l_6$  and  $l_7$  respectively from the centre of gravity of the rivet system as shown in Fig. 3.

From the geometry of the figure, we find that

$$l_1 = l_3 = \sqrt{(100)^2 + (200 - 114.3)^2} = 131.7 \text{ mm}$$

$$l_2 = 200 - 114.3 = 85.7 \text{ mm}$$

$$l_4 = l_7 = \sqrt{(100)^2 + (114.3 - 100)^2} = 101 \text{ mm}$$

$$l_5 = l_6 = \sqrt{(100)^2 + (114.3)^2} = 152 \text{ mm}$$

Now equating the turning moment due to eccentricity of the load to the resisting moment of the rivets, we have

$$\begin{aligned}
 P \times e &= \frac{F_1}{l_1} \left[ (l_1)^2 + (l_2)^2 + (l_3)^2 + (l_4)^2 + (l_5)^2 + (l_6)^2 + (l_7)^2 \right] \\
 &= \frac{F_1}{l_1} \left[ 2(l_1)^2 + (l_2)^2 + 2(l_4)^2 + 2(l_5)^2 \right] \\
 &\quad \dots (\because l_1 = l_3; l_4 = l_7 \text{ and } l_5 = l_6)
 \end{aligned}$$

$$\begin{aligned}
 50 \times 10^3 \times 400 &= \frac{F_1}{131.7} \left[ 2(131.7)^2 + (85.7)^2 + 2(101)^2 + 2(152)^2 \right] \\
 20 \times 10^6 \times 131.7 &= F_1(34\,690 + 7345 + 20\,402 + 46\,208) = 108\,645 F_1 \\
 F_1 &= 20 \times 10^6 \times 131.7 / 108\,645 = 24\,244 \text{ N}
 \end{aligned}$$

Since the secondary shear loads are proportional to their radial distances from the centre of gravity, therefore

$$\begin{aligned}
 F_2 &= F_1 \times \frac{l_2}{l_1} = 24\,244 \times \frac{85.7}{131.7} = 15\,776 \text{ N} \\
 F_3 &= F_1 \times \frac{l_3}{l_1} = F_1 = 24\,244 \text{ N} \quad \dots (\because l_1 = l_3) \\
 F_4 &= F_1 \times \frac{l_4}{l_1} = 24\,244 \times \frac{101}{131.7} = 18\,593 \text{ N}
 \end{aligned}$$

By drawing the direct and secondary shear loads on each rivet, we see that the rivets 3, 4 and 5 are heavily loaded. Let us now find the angles between the direct and secondary shear load for these three rivets. From the geometry of Fig.3, we find that

$$\begin{aligned}
 \cos \theta_3 &= \frac{100}{l_3} = \frac{100}{131.7} = 0.76 \\
 \cos \theta_4 &= \frac{100}{l_4} = \frac{100}{101} = 0.99 \\
 \cos \theta_5 &= \frac{100}{l_5} = \frac{100}{152} = 0.658
 \end{aligned}$$

Now resultant shear load on rivet 3,

$$\begin{aligned}
 R_3 &= \sqrt{(P_s)^2 + (F_3)^2 + 2P_s \times F_3 \times \cos \theta_3} \\
 &= \sqrt{(7143)^2 + (24\,244)^2 + 2 \times 7143 \times 24\,244 \times 0.76} = 30\,033 \text{ N}
 \end{aligned}$$

Resultant shear load on rivet 4,

$$R_4 = \sqrt{(P_5)^2 + (F_4)^2 + 2 P_5 \times F_4 \times \cos \theta_4}$$

$$= \sqrt{(7143)^2 + (18\ 593)^2 + 2 \times 7143 \times 18\ 593 \times 0.99} = 25\ 684\ \text{N}$$

And resultant shear load on rivet 5,

$$R_5 = \sqrt{(P_5)^2 + (F_5)^2 + 2 P_5 \times F_5 \times \cos \theta_5}$$

$$= \sqrt{(7143)^2 + (27\ 981)^2 + 2 \times 7143 \times 27\ 981 \times 0.658} = 33\ 121\ \text{N}$$

The resultant shear load may be determined graphically, as shown in Fig.3.

From above we see that the maximum resultant shear load is on rivet 5. If  $d$  is the diameter of rivet hole, then maximum resultant shear load ( $R_5$ ),

$$33\ 121 = \frac{\pi}{4} \times d^2 \times \tau = \frac{\pi}{4} \times d^2 \times 65 = 51\ d^2$$

$$d^2 = 33\ 121 / 51 = 649.4 \quad \text{or} \quad d = 25.5\ \text{mm}$$

From DDB, we see that according the standard diameter of the rivet hole ( $d$ ) is 25.5 mm and the corresponding diameter of rivet is 24 mm.

Let us now check the joint for crushing stress. We know that

$$\text{Crushing stress} = \frac{\text{Max. load}}{\text{Crushing area}} = \frac{R_5}{d \times t} = \frac{33\ 121}{25.5 \times 25}$$

$$= 51.95\ \text{N/mm}^2 = 51.95\ \text{MPa}$$

Since this stress is well below the given crushing stress of 120 MPa, therefore the design is satisfactory.

#### **References:**

1. Machine Design - V.Bandari
2. Machine Design – R.S. Khurmi
3. Design Data hand Book - S MD Jalaludin.

## **Introduction to Welded Joints**

### **Introduction**

A welded joint is a permanent joint which is obtained by the fusion of the edges of the two parts to be joined together, with or without the application of pressure and a filler material. The heat required for the fusion of the material may be obtained by burning of gas (in case of gas welding) or by an electric arc (in case of electric arc welding). The latter method is extensively used because of greater speed of welding. Welding is extensively used in fabrication as an alternative method for casting or forging and as a replacement for bolted and riveted joints. It is also used as a repair medium *e.g.* to reunite metal at a crack, to build up a small part that has broken off such as gear tooth or to repair a worn surface such as a bearing surface.

### **Advantages and Disadvantages of Welded Joints over Riveted Joints**

Following are the advantages and disadvantages of welded joints over riveted joints.

#### ***Advantages***

1. The welded structures are usually lighter than riveted structures. This is due to the reason, that in welding, gussets or other connecting components are not used.
2. The welded joints provide maximum efficiency (may be 100%) which is not possible in case of riveted joints.
3. Alterations and additions can be easily made in the existing structures.
4. As the welded structure is smooth in appearance, therefore it looks pleasing.
5. In welded connections, the tension members are not weakened as in the case of riveted joints.
6. A welded joint has a great strength. Often a welded joint has the strength of the parent metal itself.
7. Sometimes, the members are of such a shape (*i.e.* circular steel pipes) that they afford difficulty for riveting. But they can be easily welded.
8. The welding provides very rigid joints. This is in line with the modern trend of providing rigid frames.
9. It is possible to weld any part of a structure at any point. But riveting requires enough clearance.
10. The process of welding takes less time than the riveting.

#### ***Disadvantages***

1. Since there is an uneven heating and cooling during fabrication, therefore the members may get distorted or additional stresses may develop.
2. It requires a highly skilled labour and supervision.
3. Since no provision is kept for expansion and contraction in the frame, therefore there is a possibility of cracks developing in it.
4. The inspection of welding work is more difficult than riveting work.

### **Types of Welded Joints**

Following two types of welded joints are important from the subject point of view:

1. Lap joint or fillet joint, and
2. Butt joint.

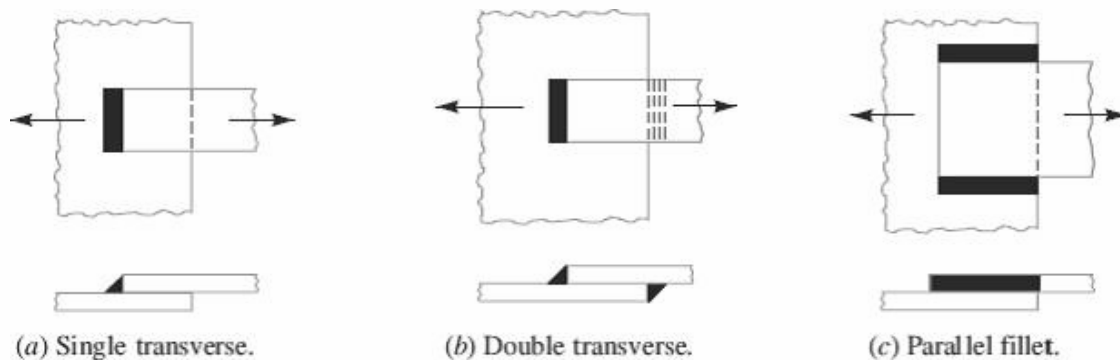

Fig.1. Types of Lab and Butt Joints

### **Lap Joint**

The lap joint or the fillet joint is obtained by overlapping the plates and then welding the edges of the plates. The cross-section of the fillet is approximately triangular. The fillet joints may be

1. Single transverse fillet,
2. Double transverse fillet and
3. Parallel fillet joints.

The fillet joints are shown in Fig.1. A single transverse fillet joint has the disadvantage that the edge of the plate which is not welded can buckle or warp out of shape.

### **Butt Joint**

The butt joint is obtained by placing the plates edge to edge as shown in Fig.2. In butt welds, the plate edges do not require beveling if the thickness of plate is less than 5 mm. On the other hand, if the plate thickness is 5 mm to 12.5 mm, the edges should be beveled to V or U-groove on both sides.

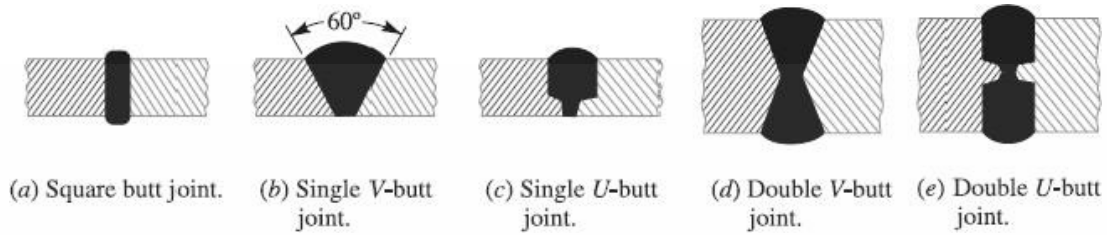

Fig. 2. Types of Butt joints

The butt joints may be

1. Square butt joint, 2. Single V-butt joint 3. Single U-butt joint,
4. Double V-butt joint, and 5. Double U-butt joint.

These joints are shown in Fig. 2.

The other type of welded joints are corner joint, edge joint and T-joint as shown in Fig. 3.

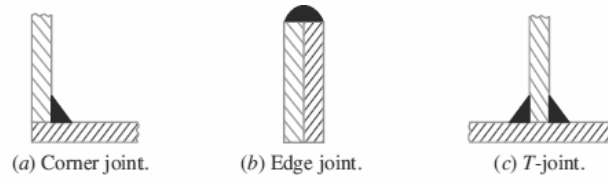

Fig. 3. Other types of Joints





### Basic Weld Symbols

S. No.	Form of weld	Sectional representation	Symbol
1.	Fillet		
2.	Square butt		
3.	Single-V butt		
4.	Double-V butt		
5.	Single-U butt		
6.	Double-U butt		
7.	Single bevel butt		
8.	Double bevel butt		

<i>S. No.</i>	<i>Form of weld</i>	<i>Sectional representation</i>	<i>Symbol</i>
9.	Single-J butt		
10.	Double-J butt		
11.	Bead (edge or seal)		
12.	Stud		
13.	Sealing run		

14.	Spot		
15.	Seam		
16.	Mashed seam		
17.	Plug		
18.	Backing strip		
19.	Stitch		
20.	Projection		
21.	Flash		
22.	Butt resistance or pressure (upset)		

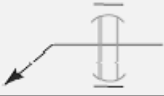
## Supplementary Weld Symbols

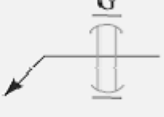
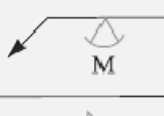
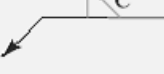
<i>S. No.</i>	<i>Particulars</i>	<i>Drawing representation</i>	<i>Symbol</i>
1.	Weld all round		○
2.	Field weld		●
3.	Flush contour		—
4.	Convex contour		⌒
5.	Concave contour		⌒
6.	Grinding finish		G
7.	Machining finish		M
8.	Chipping finish		C

### **References:**

1. Machine Design - V.Bandari .
2. Machine Design – R.S. Khurmi
3. Design Data hand Book - S MD Jalaludin.



## Elements of a welding symbol

### Elements of a Welding Symbol

A welding symbol consists of the following eight elements:

1. Reference line, 2. Arrow,
3. Basic weld symbols, 4. Dimensions and other data,
5. Supplementary symbols, 6. Finish symbols,
7. Tail, and 8. Specification, process or other references.

### Standard Location of Elements of a Welding Symbol

The arrow points to the location of weld, the basic symbols with dimensions are located on one or both sides of reference line. The specification if any is placed in the tail of arrow. Fig. 1. shows the standard locations of welding symbols represented on drawing.

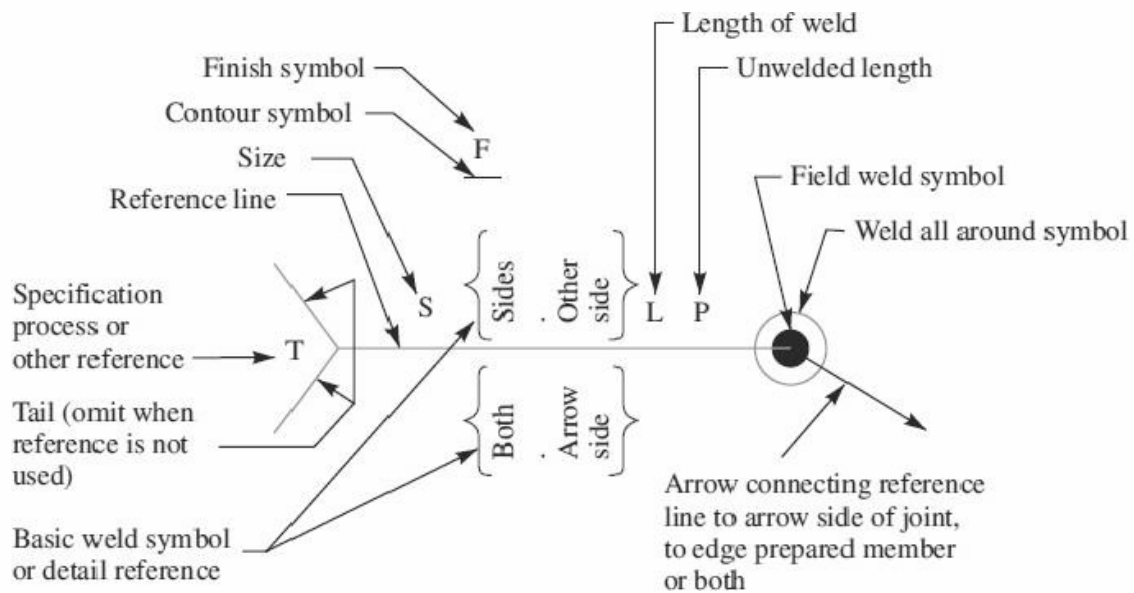
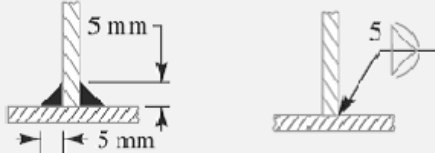

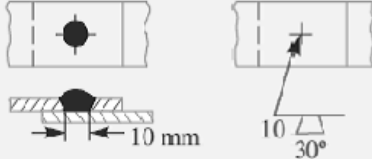
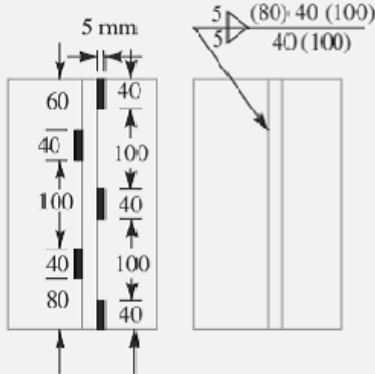

Fig.1 Standard location of weld symbols.

Some of the examples of welding symbols represented on drawing are shown in the following table.

**Representation of welding symbols.**

S. No.	Desired weld	Representation on drawing
1.	Fillet-weld each side of Tee- convex contour	
2.	Single V-butt weld -machining finish	
3.	Double V- butt weld	
4.	Plug weld - 30° Groove-angle-flush contour	
5.	Staggered intermittent fillet welds	

**References:**

1. Machine Design - V.Bandari .
2. Machine Design – R.S. Khurmi
3. Design Data hand Book - S MD Jalaludin.

Contents: Design of **Welded Joints**

### **Strength of Transverse Fillet Welded Joints**

We have already discussed that the fillet or lap joint is obtained by overlapping the plates and then welding the edges of the plates. The transverse fillet welds are designed for tensile strength. Let us consider a single and double transverse fillet welds as shown in Fig. 1(a) and (b) respectively.

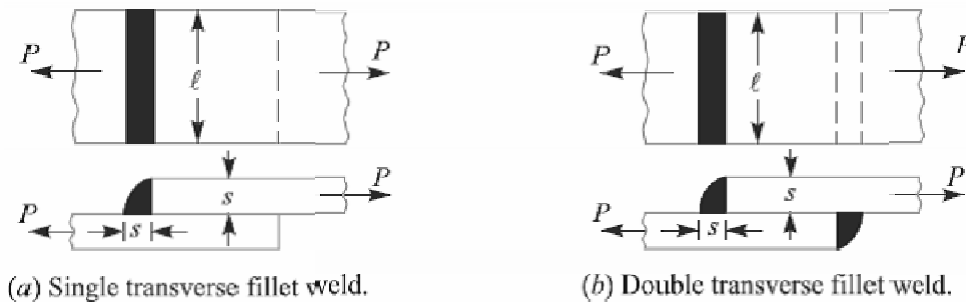

Fig.1 Transverse fillet welds.

The length of each side is known as **leg** or **size of the weld** and the perpendicular distance of the hypotenuse from the intersection of legs (*i.e.*  $BD$ ) is known as **throat thickness**. The minimum area of the weld is obtained at the throat  $BD$ , which is given by the product of the throat thickness and length of weld.

Let  $t$  = Throat thickness ( $BD$ ),

$s$  = Leg or size of weld,

$t$  = Thickness of plate, and

$l$  = Length of weld,

From Fig.2, we find that the throat thickness,

$$t = s \times \sin 45^\circ = 0.707 s$$

Therefore, Minimum area of the weld or throat area,

$$\begin{aligned} A &= \text{Throat thickness} \times \text{Length of weld} \\ &= t \times l = 0.707 s \times l \end{aligned}$$

If  $\sigma_t$  is the allowable tensile stress for the weld metal, then the tensile strength of the joint for single fillet weld,

$$P = \text{Throat area} \times \text{Allowable tensile stress} = 0.707 s \times l \times \sigma_t$$

And tensile strength of the joint for double fillet weld,

$$P = 2 \times 0.707 s \times l \times \sigma_t = 1.414 s \times l \times \sigma_t$$

**Note:** Since the weld is weaker than the plate due to slag and blow holes, therefore the weld is given a reinforcement which may be taken as 10% of the plate thickness.

### **Strength of Parallel Fillet Welded Joints**

The parallel fillet welded joints are designed for shear strength. Consider a double parallel fillet welded joint as shown in Fig.3 (a). We have already discussed in the previous article, that the minimum area of weld or the throat area,

$$A = 0.707 s \times l$$

If  $\tau$  is the allowable shear stress for the weld metal, then the shear strength of the joint for single parallel fillet weld,

$$P = \text{Throat area} \times \text{Allowable shear stress} = 0.707 s \times l \times \tau$$

And shear strength of the joint for double parallel fillet weld,

$$P = 2 \times 0.707 \times s \times l \times \tau = 1.414 s \times l \times \tau$$

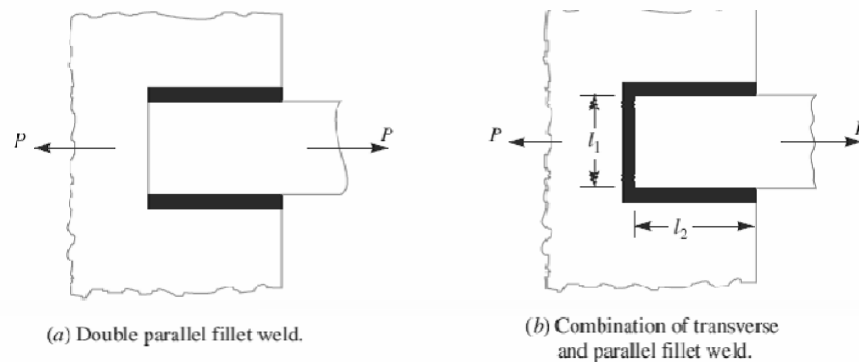

Fig.3

**Notes: 1.** If there is a combination of single transverse and double parallel fillet welds as shown in Fig. (b), then the strength of the joint is given by the sum of strengths of single transverse and double parallel fillet welds. Mathematically,

$$P = 0.707s \times l_1 \times \sigma_t + 1.414 s \times l_2 \times \tau$$

Where  $l_1$  is normally the width of the plate.

**2.** In order to allow for starting and stopping of the bead, 12.5 mm should be added to the length of each weld obtained by the above expression.

**3.** For reinforced fillet welds, the throat dimension may be taken as  $0.85 t$ .

**Problem:**

A plate 100 mm wide and 10 mm thick is to be welded to another plate by means of double parallel fillets. The plates are subjected to a static load of 80 kN. Find the length of weld if the permissible shear stress in the weld does not exceed 55 MPa.

**Solution. Given:** \*Width = 100 mm ;  
 Thickness = 10 mm ;  $P = 80 \text{ kN} = 80 \times 10^3 \text{ N}$  ;  
 $\tau = 55 \text{ MPa} = 55 \text{ N/mm}^2$

Let  $l$  = Length of weld, and  
 $s$  = Size of weld = Plate thickness = 10 mm  
 ... (Given)

We know that maximum load which the plates can carry for double parallel fillet weld ( $P$ ),

$$80 \times 10^3 = 1.414 \times s \times l \times \tau = 1.414 \times 10 \times l \times 55 = 778 l$$

$$\therefore l = 80 \times 10^3 / 778 = 103 \text{ mm}$$

Adding 12.5 mm for starting and stopping of weld run, we have

$$l = 103 + 12.5 = 115.5 \text{ mm Ans.}$$

### Strength of Butt Joints

The butt joints are designed for tension or compression. Consider a single V-butt joint as shown in Fig. 4(a).

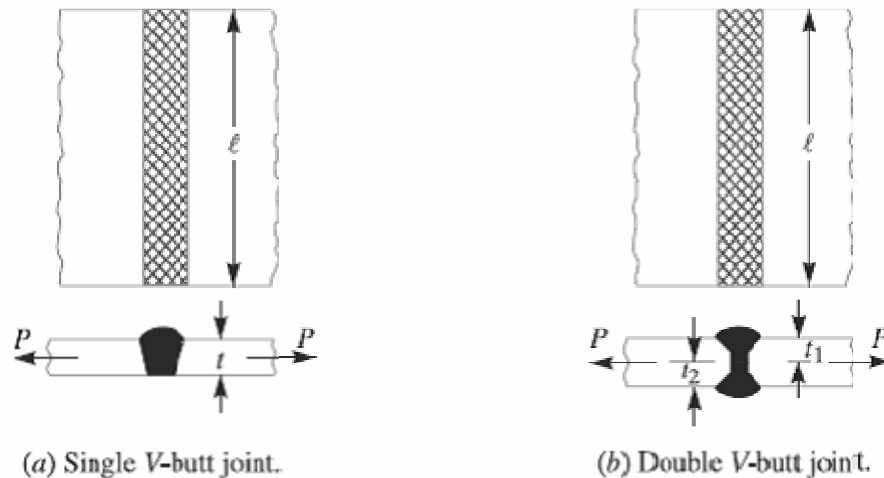

Fig.4. Butt Joints

In case of butt joint, the length of leg or size of weld is equal to the throat thickness which is equal to thickness of plates. Therefore, Tensile strength of the butt joint (single-V or square butt joint),

$$P = t \times l \times \sigma_t$$

Where  $l$  = Length of weld. It is generally equal to the width of plate. And tensile strength for double-V butt joint as shown in Fig. 4(b) is given by

$$P = (t_1 + t_2) l \times \sigma_t$$

Where  $t_1$  = Throat thickness at the top, and  
 $t_2$  = Throat thickness at the bottom.

It may be noted that size of the weld should be greater than the thickness of the plate, but it may be less. The following table shows recommended minimum size of the welds.

### **Stresses for Welded Joints**

The stresses in welded joints are difficult to determine because of the variable and unpredictable parameters like homogeneity of the weld metal, thermal stresses in the welds, changes of physical properties due to high rate of cooling etc. The stresses are obtained, on the following assumptions:

1. The load is distributed uniformly along the entire length of the weld, and
2. The stress is spread uniformly over its effective section.

The following table shows the stresses for welded joints for joining ferrous metals with mild steel electrode under steady and fatigue or reversed load.

### **Stress Concentration Factor for Welded Joints**

The reinforcement provided to the weld produces stress concentration at the junction of the weld and the parent metal. When the parts are subjected to fatigue loading, the stress concentration factors should be taken into account.

### **References:**

1. Machine Design - V.Bandari .
2. Machine Design – R.S. Khurmi
3. Design Data hand Book - S MD Jalaludin.

Problem:

A plate 100 mm wide and 12.5 mm thick is to be welded to another plate by means of parallel fillet welds. The plates are subjected to a load of 50 kN. Find the length of the weld so that the maximum stress does not exceed 56 MPa. Consider the joint first under static loading and then under fatigue loading.

**Solution.** Given: \*Width = 100 mm ; Thickness = 12.5 mm ;  $P = 50 \text{ kN} = 50 \times 10^3 \text{ N}$  ;  $\tau = 56 \text{ MPa} = 56 \text{ N/mm}^2$

*Length of weld for static loading*

Let  $l$  = Length of weld, and

$s$  = Size of weld = Plate thickness

= 12.5 mm ... (Given)

We know that the maximum load which the plates can carry for double parallel fillet welds ( $P$ ),

$$50 \times 10^3 = 1.414 s \times l \times \tau$$

$$= 1.414 \times 12.5 \times l \times 56 = 990 l$$

$$\therefore l = 50 \times 10^3 / 990 = 50.5 \text{ mm}$$

Adding 12.5 mm for starting and stopping of weld run, we have

$$l = 50.5 + 12.5 = 63 \text{ mm Ans.}$$

*Length of weld for fatigue loading*

From Table 10.6, we find that the stress concentration factor for parallel fillet welding is 2.7.

$\therefore$  Permissible shear stress,

$$\tau = 56 / 2.7 = 20.74 \text{ N/mm}^2$$

We know that the maximum load which the plates can carry for double parallel fillet welds ( $P$ ),

$$50 \times 10^3 = 1.414 s \times l \times \tau = 1.414 \times 12.5 \times l \times 20.74 = 367 l$$

$$\therefore l = 50 \times 10^3 / 367 = 136.2 \text{ mm}$$

Adding 12.5 for starting and stopping of weld run, we have

$$l = 136.2 + 12.5 = 148.7 \text{ mm Ans.}$$

Problem:

A plate 75 mm wide and 12.5 mm thick is joined with another plate by a single transverse weld and a double parallel fillet weld as shown in Fig. The maximum tensile and shear stresses are 70 MPa and 56 MPa respectively. Find the length of each parallel fillet weld, if the joint is subjected to both static and fatigue loading.

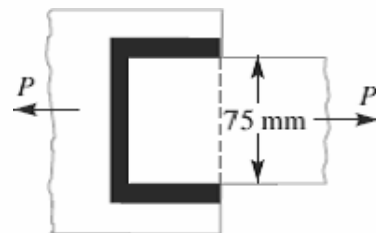

**Solution.** Given : Width = 75 mm ; Thickness = 12.5 mm ;  
 $\sigma_t = 70 \text{ MPa} = 70 \text{ N/mm}^2$  ;  $\tau = 56 \text{ MPa} = 56 \text{ N/mm}^2$ .

The effective length of weld ( $l_1$ ) for the transverse weld may be obtained by subtracting 12.5 mm from the width of the plate.

$$\therefore l_1 = 75 - 12.5 = 62.5 \text{ mm}$$

*Length of each parallel fillet for static loading*

Let  $l_2 =$  Length of each parallel fillet.

We know that the maximum load which the plate can carry is

$$P = \text{Area} \times \text{Stress} = 75 \times 12.5 \times 70 = 65\,625 \text{ N}$$

Load carried by single transverse weld,

$$P_1 = 0.707 s \times l_1 \times \sigma_t = 0.707 \times 12.5 \times 62.5 \times 70 = 38\,664 \text{ N}$$

and the load carried by double parallel fillet weld,

$$P_2 = 1.414 s \times l_2 \times \tau = 1.414 \times 12.5 \times l_2 \times 56 = 990 l_2 \text{ N}$$

$\therefore$  Load carried by the joint ( $P$ ),

$$65\,625 = P_1 + P_2 = 38\,664 + 990 l_2 \quad \text{or} \quad l_2 = 27.2 \text{ mm}$$

Adding 12.5 mm for starting and stopping of weld run, we have

$$l_2 = 27.2 + 12.5 = 39.7 \text{ say } 40 \text{ mm Ans.}$$

*Length of each parallel fillet for fatigue loading*

From Table 10.6, we find that the stress concentration factor for transverse welds is 1.5 and for parallel fillet welds is 2.7.

$\therefore$  Permissible tensile stress,

$$\sigma_t = 70 / 1.5 = 46.7 \text{ N/mm}^2$$

and permissible shear stress,

$$\tau = 56 / 2.7 = 20.74 \text{ N/mm}^2$$

Load carried by single transverse weld,

$$P_1 = 0.707 s \times l_1 \times \sigma_t = 0.707 \times 12.5 \times 62.5 \times 46.7 = 25\,795 \text{ N}$$

and load carried by double parallel fillet weld,

$$P_2 = 1.414 s \times l_2 \times \tau = 1.414 \times 12.5 l_2 \times 20.74 = 366 l_2 \text{ N}$$

$\therefore$  Load carried by the joint ( $P$ ),

$$65\,625 = P_1 + P_2 = 25\,795 + 366 l_2 \quad \text{or} \quad l_2 = 108.8 \text{ mm}$$

Adding 12.5 mm for starting and stopping of weld run, we have

$$l_2 = 108.8 + 12.5 = 121.3 \text{ mm Ans.}$$

### **References:**

1. Machine Design - V.Bandari .
2. Machine Design – R.S. Khurmi
3. Design Data hand Book - S MD Jalaludin.



Contents: Special fillet welded j

### **Special Cases of Fillet Welded Joints**

The following cases of fillet welded joints are important from the subject point of view.

**1. Circular fillet weld subjected to torsion.** Consider a circular rod connected to a rigid plate by a fillet weld as shown in Fig. 1.

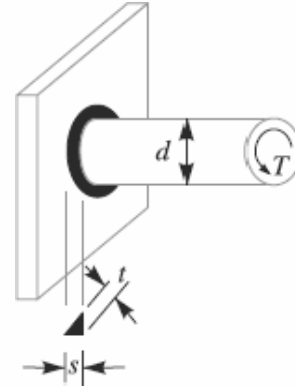

Fig. 1. Circular fillet weld subjected to torsion.

Let  $d$  = Diameter of rod,

$r$  = Radius of rod,

$T$  = Torque acting on the rod,

$s$  = Size (or leg) of weld,

$t$  = Throat thickness,

$J$  = Polar moment of inertia of the

$$\text{weld section} = \frac{\pi t d^3}{4}$$

We know that shear stress for the material,

$$\begin{aligned} \tau &= \frac{Tr}{J} = \frac{T \times d/2}{J} \\ &= \frac{T \times d/2}{\pi t d^3 / 4} = \frac{2T}{\pi t d^2} \end{aligned}$$

This shear stress occurs in a horizontal plane along a leg of the fillet weld. The maximum shear occurs on the throat of weld which is inclined at  $45^\circ$  to the horizontal plane.

Length of throat,  $t = s \sin 45^\circ = 0.707 s$  and maximum shear stress,

$$\tau_{max} = \frac{2T}{\pi \times 0.707 s \times d^2} = \frac{2.83 T}{\pi s d^2}$$

### **2. Circular fillet weld subjected to bending moment.**

Consider a circular rod connected to a rigid plate by a fillet weld as shown in Fig.2.

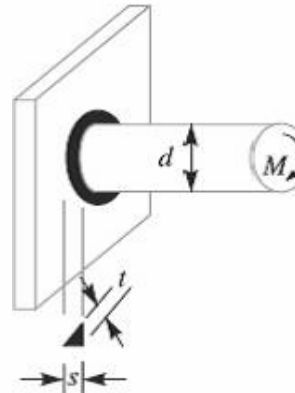

Fig.2. Circular fillet weld subjected to Bending moment.

Let  $d$  = Diameter of rod,

$M$  = Bending moment acting on the rod,

$s$  = Size (or leg) of weld,

$t$  = Throat thickness,

Z = Section modulus of the weld section

$$= \frac{\pi t d^2}{4}$$

We know that the bending stress

$$\sigma_b = \frac{M}{Z} = \frac{M}{\pi t d^2 / 4} = \frac{4M}{\pi t d^2}$$

This bending stress occurs in a horizontal plane along a leg of the fillet weld. The maximum bending stress occurs on the throat of the weld which is inclined at 45° to the horizontal plane.

Length of throat,  $t = s \sin 45^\circ = 0.707 s$  and maximum bending stress,

$$\sigma_{b(max)} = \frac{4M}{\pi \times 0.707 s \times d^2} = \frac{5.66 M}{\pi s d^2}$$

**3. Long fillet weld subjected to torsion.** Consider a vertical plate attached to a horizontal plate by two identical fillet welds as shown in Fig.3.

Let T = Torque acting on the vertical plate,

l = Length of weld,

s = Size (or leg) of weld,

t = Throat thickness, and

J = Polar moment of inertia of the weld section

$$= 2 \times \frac{t \times l^3}{12} = \frac{t \times l^3}{6} \dots$$

It may be noted that the effect of the applied torque is to rotate the vertical plate about the Z- axis through its mid point. This rotation is resisted by shearing stresses developed between two fillet welds and the horizontal plate. It is assumed that these horizontal shearing stresses vary from zero at the Z-axis and maximum at the ends of the plate. This variation of shearing stress is analogous to the variation of normal stress over the depth (l) of a beam subjected to pure bending. Therefore, Shear stress,

$$\tau = \frac{T \times l / 2}{t \times l^3 / 6} = \frac{3T}{t \times l^2}$$

The maximum shear stress occurs at the throat and is given by

$$\tau_{max} = \frac{3T}{0.707s \times l^2} = \frac{4.242 T}{s \times l^2}$$

**References:**

1. Machine Design - V.Bandari .
2. Machine Design – R.S. Khurmi
3. Design Data hand Book - S MD Jalaludin.

## Contents: Unsymmetrical welded joints

### Axially Loaded Unsymmetrical Welded Sections

Sometimes unsymmetrical sections such as angles, channels, *T*-sections etc., welded on the flange edges are loaded axially as shown in Fig. In such cases, the lengths of weld should be proportioned in such a way that the sum of resisting moments of the welds about the gravity axis is zero. Consider an angle section as shown in Fig.

Let  $l_a$  = Length of weld at the top,

$l_b$  = Length of weld at the bottom,

$l$  = Total length of weld =  $l_a + l_b$

$P$  = Axial load,

$a$  = Distance of top weld from gravity axis,

$b$  = Distance of bottom weld from gravity axis, and

$f$  = Resistance offered by the weld per unit length.

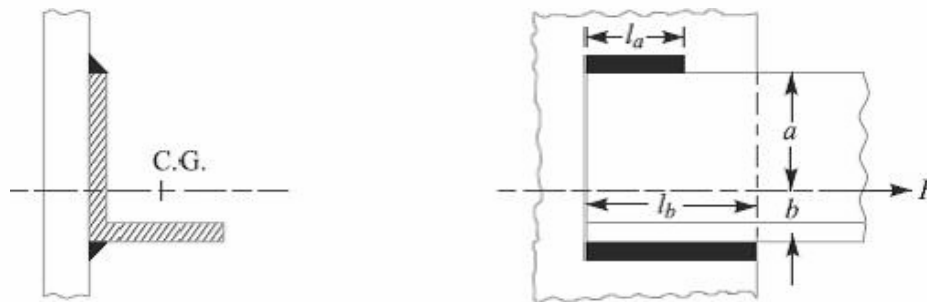

**Fig.** Axially loaded unsymmetrical welded section

Moment of the top weld about gravity axis

$$= l_a \times f \times a$$

And moment of the bottom weld about gravity axis

$$= l_b \times f \times b$$

Since the sum of the moments of the weld about the gravity axis must be zero, therefore,

$$l_a \times f \times a - l_b \times f \times b = 0$$

$$\text{or } l_a \times a = l_b \times b \quad \dots(i)$$

We know that  $l = l_a + l_b \quad \dots(ii)$

From equations (i) and (ii), we have

$$l_a = \frac{l \times b}{a + b}, \quad \text{and} \quad l_b = \frac{l \times a}{a + b}$$

**References:**

1. Machine Design - V.Bandari .
2. Machine Design – R.S. Khurmi
3. Design Data hand Book - S MD Jalaludin.

## Eccentrically Loaded Welded

An eccentric load may be imposed on welded joints in many ways. The stresses induced on the joint may be of different nature or of the same nature. The induced stresses are combined depending upon the nature of stresses. When the shear and bending stresses are simultaneously present in a joint (see case 1), then maximum stresses are as follows:

Maximum normal stress,

$$\sigma_{t(max)} = \frac{\sigma_b}{2} + \frac{1}{2} \sqrt{(\sigma_b)^2 + 4 \tau^2}$$

And Maximum shear stress,

$$\tau_{max} = \frac{1}{2} \sqrt{(\sigma_b)^2 + 4 \tau^2}$$

Where  $\sigma_b$  = Bending stress, and

$\tau$  = Shear stress.

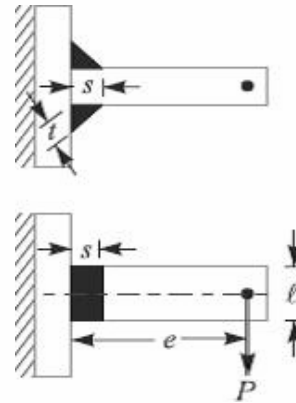

Fig.1. Eccentrically loaded welded joint

When the stresses are of the same nature, these may be combined vectorially (see case 2).

We shall now discuss the two cases of eccentric loading as follows:

### Case 1

Consider a *T*-joint fixed at one end and subjected to an eccentric load *P* at a distance *e* as shown in Fig. 1

Let *s* = Size of weld,

*l* = Length of weld, and

*t* = Throat thickness.

The joint will be subjected to the following two types of stresses:

1. Direct shear stress due to the shear force *P* acting at the welds, and
2. Bending stress due to the bending moment  $P \times e$ .

We know that area at the throat,

$$\begin{aligned} A &= \text{Throat thickness} \times \text{Length of weld} \\ &= t \times l \times 2 = 2 t \times l \dots \text{(For double fillet weld)} \\ &= 2 \times 0.707 s \times l = 1.414 s \times l \dots \text{(since, } t = s \cos 45^\circ = 0.707 s) \end{aligned}$$

Shear stress in the weld (assumed uniformly distributed),

$$\tau = \frac{P}{A} = \frac{P}{1.414 s \times l}$$

Section modulus of the weld metal through the throat,

$$Z = \frac{t \times l^2}{6} \times 2 \quad \dots(\text{For both sides weld})$$

$$= \frac{0.707s \times l^2}{6} \times 2 = \frac{s \times l^2}{4.242}$$

Bending moment,  $M = P \times e$

$$\therefore \text{Bending stress, } \sigma_b = \frac{M}{Z} = \frac{P \times e \times 4.242}{s \times l^2} = \frac{4.242 P \times e}{s \times l^2}$$

We know that the maximum normal stress,

$$\sigma_{t(max)} = \frac{1}{2} \sigma_b + \frac{1}{2} \sqrt{(\sigma_b)^2 + 4 \tau^2}$$

And maximum shear stress,

$$\tau_{max} = \frac{1}{2} \sqrt{(\sigma_b)^2 + 4 \tau^2}$$

**Case 2**

When a welded joint is loaded eccentrically as shown in Fig.2, the following two types of the stresses are induced:

1. Direct or primary shear stress, and
2. Shear stress due to turning moment.

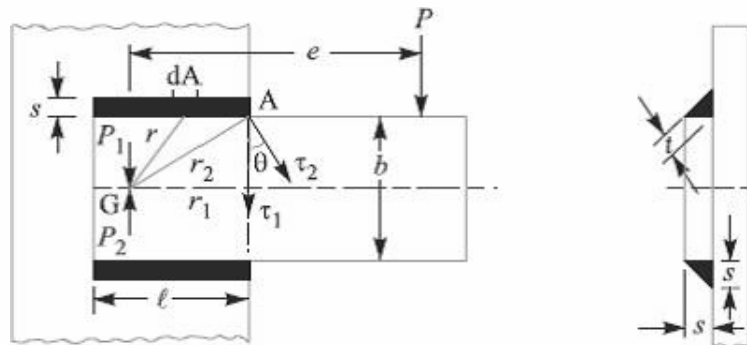

Fig.2 eccentrically loaded welded joint.

Let  $P$  = Eccentric load,

$e$  = Eccentricity i.e. perpendicular distance between the line of action of load and centre of gravity (G) of the throat section or fillets,

$l$  = Length of single weld,

$s$  = Size or leg of weld, and

$t$  = Throat thickness.

Let two loads  $P_1$  and  $P_2$  (each equal to  $P$ ) are introduced at the centre of gravity 'G' of the weld system. The effect of load  $P_1 = P$  is to produce direct shear stress which is assumed to be uniform over the entire weld length. The effect of load  $P_2 = P$  is to produce a turning moment of magnitude  $P \times e$  which tends to rotate the joint about the centre of gravity 'G' of the weld system. Due to the turning moment, secondary shear stress is induced.

We know that the direct or primary shear stress,

$$\begin{aligned}\tau_1 &= \frac{\text{Load}}{\text{Throat area}} = \frac{P}{A} = \frac{P}{2t \times l} \\ &= \frac{P}{2 \times 0.707s \times l} = \frac{P}{1.414s \times l}\end{aligned}$$

Since the shear stress produced due to the turning moment ( $T = P \times e$ ) at any section is proportional to its radial distance from G, therefore stress due to  $P \times e$  at the point A is proportional to AG ( $r_2$ ) and is in a direction at right angles to AG. In other words,

$$\begin{aligned}\frac{\tau_2}{r_2} &= \frac{\tau}{r} = \text{Constant} \\ \tau &= \frac{\tau_2}{r_2} \times r \quad \dots(i)\end{aligned}$$

Where  $\tau_2$  is the shear stress at the maximum distance ( $r_2$ ) and  $\tau$  is the shear stress at any distance  $r$ . Consider a small section of the weld having area  $dA$  at a distance  $r$  from G.

Shear force on this small section

$$= \tau \times dA$$

And turning moment of this shear force about G,

$$dT = \tau \times dA \times r = \frac{\tau_2}{r_2} \times dA \times r^2 \quad \dots \text{ [ From equation (i) ]}$$

Total turning moment over the whole weld area,



$$T = P \times e = \int \frac{\tau_2}{r_2} \times dA \times r^2 = \frac{\tau_2}{r_2} \int dA \times r^2$$

$$= \frac{\tau_2}{r_2} \times J \quad (\because J = \int dA \times r^2)$$

Where J = Polar moment of inertia of the throat area about G.

□ Shear stress due to the turning moment i.e. secondary shear stress,

$$\tau_2 = \frac{T \times r_2}{J} = \frac{P \times e \times r_2}{J}$$

In order to find the resultant stress, the primary and secondary shear stresses are combined vectorially.

Resultant shear stress at A,

$$\tau_A = \sqrt{(\tau_1)^2 + (\tau_2)^2 + 2\tau_1 \times \tau_2 \times \cos \theta}$$

$\theta$  = Angle between  $\tau_1$  and  $\tau_2$ , and  
 $\cos \theta = r_1 / r_2$

**References:**

1. Machine Design - V.Bandari .
2. Machine Design – R.S. Khurmi
3. Design Data hand Book - S MD Jalaludin

Problem:

A welded joint as shown in Fig. 10.24, is subjected to an eccentric load of 2 kN. Find the size of weld, if the maximum shear stress in the weld is 25 MPa.

**Solution.** Given:  $P = 2 \text{ kN} = 2000 \text{ N}$ ;  $e = 120 \text{ mm}$ ;  
 $l = 40 \text{ mm}$ ;  $\tau_{max} = 25 \text{ MPa} = 25 \text{ N/mm}^2$

Let  $s =$  Size of weld in mm, and  
 $t =$  Throat thickness.

The joint, as shown in Fig. 10.24, will be subjected to direct shear stress due to the shear force,  $P = 2000 \text{ N}$  and bending stress due to the bending moment of  $P \times e$ .

We know that area at the throat,

$$\begin{aligned} A &= 2t \times l = 2 \times 0.707 s \times l \\ &= 1.414 s \times l \\ &= 1.414 s \times 40 = 56.56 \times s \text{ mm}^2 \end{aligned}$$

$$\therefore \text{Shear stress, } \tau = \frac{P}{A} = \frac{2000}{56.56 \times s} = \frac{35.4}{s} \text{ N/mm}^2$$

$$\text{Bending moment, } M = P \times e = 2000 \times 120 = 240 \times 10^3 \text{ N-mm}$$

Section modulus of the weld through the throat,

$$Z = \frac{s \times l^2}{4.242} = \frac{s (40)^2}{4.242} = 377 \times s \text{ mm}^3$$

$$\therefore \text{Bending stress, } \sigma_b = \frac{M}{Z} = \frac{240 \times 10^3}{377 \times s} = \frac{636.6}{s} \text{ N/mm}^2$$

We know that maximum shear stress ( $\tau_{max}$ ),

$$25 = \frac{1}{2} \sqrt{(\sigma_b)^2 + 4 \tau^2} = \frac{1}{2} \sqrt{\left(\frac{636.6}{s}\right)^2 + 4 \left(\frac{35.4}{s}\right)^2} = \frac{320.3}{s}$$

$$\therefore s = 320.3 / 25 = 12.8 \text{ mm Ans.}$$

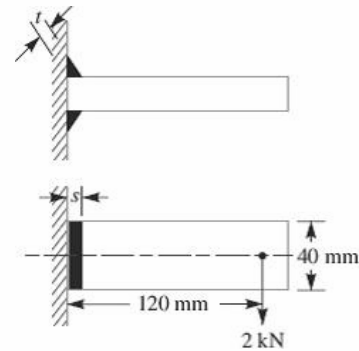

Problem:

A bracket carrying a load of 15 kN is to be welded as shown in Fig. Find the size of weld required if the allowable shear stress is not to exceed 80 MPa.

**Solution.** Given :  $P = 15 \text{ kN} = 15 \times 10^3 \text{ N}$ ;  $\tau = 80 \text{ MPa} = 80 \text{ N/mm}^2$ ;  $b = 80 \text{ mm}$ ;  
 $l = 50 \text{ mm}$ ;  $e = 125 \text{ mm}$

Let  $s =$  Size of weld in mm, and  
 $t =$  Throat thickness.

We know that the throat area,

$$\begin{aligned} A &= 2 \times t \times l = 2 \times 0.707 s \times l \\ &= 1.414 s \times l = 1.414 \times s \times 50 = 70.7 s \text{ mm}^2 \end{aligned}$$

∴ Direct or primary shear stress,

$$\tau_1 = \frac{P}{A} = \frac{15 \times 10^3}{70.7 s} = \frac{212}{s} \text{ N/mm}^2$$

$$J = \frac{t.l (3b^2 + l^2)}{6} = \frac{0.707 s \times 50 [3 (80)^2 + (50)^2]}{6} \text{ mm}^4$$

$$= 127\,850 s \text{ mm}^4 \quad \dots (\because t = 0.707 s)$$

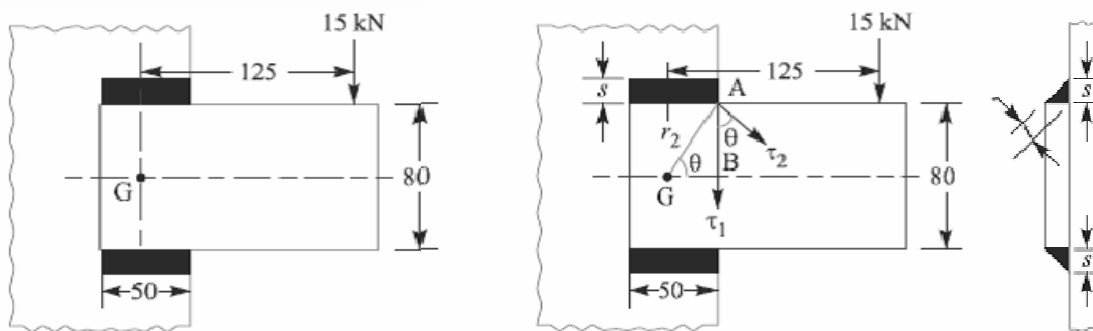

All dimensions in mm.

∴ Maximum radius of the weld,

$$r_2 = \sqrt{(AB)^2 + (BG)^2} = \sqrt{(40)^2 + (25)^2} = 47 \text{ mm}$$

Shear stress due to the turning moment *i.e.* secondary shear stress,

$$\tau_2 = \frac{P \times e \times r_2}{J} = \frac{15 \times 10^3 \times 125 \times 47}{127\,850 s} = \frac{689.3}{s} \text{ N/mm}^2$$

and

$$\cos \theta = \frac{r_1}{r_2} = \frac{25}{47} = 0.532$$

We know that resultant shear stress,

$$\tau = \sqrt{(\tau_1)^2 + (\tau_2)^2 + 2 \tau_1 \times \tau_2 \cos \theta}$$

$$80 = \sqrt{\left(\frac{212}{s}\right)^2 + \left(\frac{689.3}{s}\right)^2 + 2 \times \frac{212}{s} \times \frac{689.3}{s} \times 0.532} = \frac{822}{s}$$

∴  $s = 822 / 80 = 10.3 \text{ mm Ans.}$

### References:

1. Machine Design - V. Bandari
2. Machine Design – R.S. Khurmi
3. Design Data hand Book - S MD Jalaludin.

### **Introduction to Screwed Joints:**

A screw thread is formed by cutting a continuous helical groove on a cylindrical surface. A screw made by cutting a single helical groove on the cylinder is known as **single threaded** (or single-start) screw and if a second thread is cut in the space between the grooves of the first, a **double threaded** (or double-start) screw is formed. Similarly, triple and quadruple (i.e. multiple-start) threads may be formed. The helical grooves may be cut either **right hand** or **left hand**.

A screwed joint is mainly composed of two elements i.e. a bolt and nut. The screwed joints are widely used where the machine parts are required to be readily connected or disconnected without damage to the machine or the fastening. This may be for the purpose of holding or adjustment in assembly or service inspection, repair, or replacement or it may be for the manufacturing or assembly reasons. The parts may be rigidly connected or provisions may be made for predetermined relative motion.

### **Advantages and Disadvantages of Screwed Joints**

Following are the advantages and disadvantages of the screwed joints.

#### **Advantages**

1. Screwed joints are highly reliable in operation.
2. Screwed joints are convenient to assemble and disassemble.
3. A wide range of screwed joints may be adapted to various operating conditions.
4. Screws are relatively cheap to produce due to standardization and highly efficient manufacturing processes.

#### **Disadvantages**

The main disadvantage of the screwed joints is the stress concentration in the threaded portions which are vulnerable points under variable load conditions.

**Note :** The strength of the screwed joints is not comparable with that of riveted or welded joints.

### **Important Terms Used in Screw Threads**

The following terms used in screw threads, as shown in Fig. 1, are important from the subject point of view:

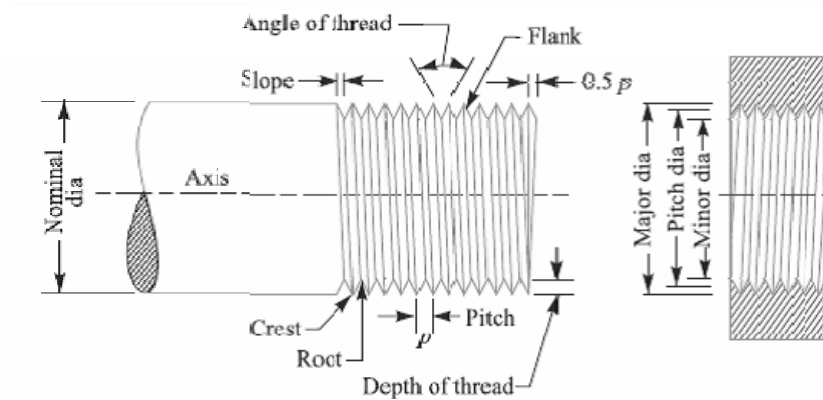

Fig.1 Terms used in screw threads

**1. Major diameter.** It is the largest diameter of an external or internal screw thread. The screw is specified by this diameter. It is also known as **outside** or **nominal diameter**.

**2. Minor diameter.** It is the smallest diameter of an external or internal screw thread. It is also known as **core** or **root diameter**.

**3. Pitch diameter.** It is the diameter of an imaginary cylinder, on a cylindrical screw thread, the surface of which would pass through the thread at such points as to make equal the width of the thread and the width of the spaces between the threads. It is also called an **effective diameter**. In a nut and bolt assembly, it is the diameter at which the ridges on the bolt are in complete touch with the ridges of the corresponding nut.

**4. Pitch.** It is the distance from a point on one thread to the corresponding point on the next. This is measured in an axial direction between corresponding points in the same axial plane. Mathematically,

$$\text{Pitch} = \frac{1}{\text{No. of threads per unit length of screw}}$$

**5. Lead.** It is the distance between two corresponding points on the same helix. It may also be defined as the distance which a screw thread advances axially in one rotation of the nut. Lead is equal to the pitch in case of single start threads, it is twice the pitch in double start, thrice the pitch in triple start and so on.

**6. Crest.** It is the top surface of the thread.

**7. Root.** It is the bottom surface created by the two adjacent flanks of the thread.

**8. Depth of thread.** It is the perpendicular distance between the crest and root.

**9. Flank.** It is the surface joining the crest and root.

**10. Angle of thread.** It is the angle included by the flanks of the thread.

**11. Slope.** It is half the pitch of the thread.

**References:**

1. Machine Design - V.Bandari .
2. Machine Design – R.S. Khurmi
3. Design Data hand Book - S MD Jalaludin.

### **Stresses in Screwed Fastening due to Static Loading**

The following stresses in screwed fastening due to static loading are important from the subject point of view:

1. Internal stresses due to screwing up forces,
2. Stresses due to external forces, and
3. Stress due to combination of stresses at (1) and (2).

### **Initial Stresses due to Screwing up Forces**

The following stresses are induced in a bolt, screw or stud when it is screwed up tightly.

**1. Tensile stress due to stretching of bolt.** Since none of the above-mentioned stresses are accurately determined, therefore bolts are designed on the basis of direct tensile stress with a large factor of safety in order to account for the indeterminate stresses. The initial tension in a bolt, based on experiments, may be found by the relation

$$P_i = 2840 d N$$

Where  $P_i$  = Initial tension in a bolt, and

$d$  = Nominal diameter of bolt, in mm.

The above relation is used for making a joint fluid tight like steam engine cylinder cover joints etc. When the joint is not required as tight as fluid-tight joint, then the initial tension in a bolt may be reduced to half of the above value. In such cases

$$P_i = 1420 d N$$

The small diameter bolts may fail during tightening, therefore bolts of smaller diameter (less than M 16 or M 18) are not permitted in making fluid tight joints. If the bolt is not initially stressed, then the maximum safe axial load which may be applied to it, is given by

$P$  = Permissible stress  $\times$  Cross-sectional area at bottom of the thread

$$\text{Stress area} = \frac{\pi}{4} \left( \frac{d_p + d_c}{2} \right)^2$$

Where  $d_p$  = Pitch diameter, and

$d_c$  = Core or minor diameter.

### **Stresses due to External Forces**

The following stresses are induced in a bolt when it is subjected to an external load.

**1. Tensile stress.** The bolts, studs and screws usually carry a load in the direction of the bolt axis which induces a tensile stress in the bolt.

Let  $d_c$  = Root or core diameter of the thread, and

$\sigma_t$  = Permissible tensile stress for the bolt material.

We know that external load applied,

$$P = \frac{\pi}{4} (d_c)^2 \sigma_t$$

$$d_c = \sqrt{\frac{4P}{\pi \sigma_t}}$$

**Notes:** (a) if the external load is taken up by a number of bolts, then

$$P = \frac{\pi}{4} (d_c)^2 \sigma_t \times n$$

(b) In case the standard table is not available, then for coarse threads,  $d_c = 0.84 d$ , where  $d$  is the nominal diameter of bolt.

**2. Shear stress.** Sometimes, the bolts are used to prevent the relative movement of two or more parts, as in case of flange coupling, and then the shear stress is induced in the bolts. The shear stresses should be avoided as far as possible. It should be noted that when the bolts are subjected to direct shearing loads, they should be located in such a way that the shearing load comes upon the body (i.e. shank) of the bolt and not upon the threaded portion. In some cases, the bolts may be relieved of shear load by using shear pins. When a number of bolts are used to share the shearing load, the finished bolts should be fitted to the reamed holes.

Let  $d$  = Major diameter of the bolt, and

$n$  = Number of bolts.

Shearing load carried by the bolts,

$$P_s = \frac{\pi}{4} \times d^2 \times \tau \times n \quad \text{or} \quad d = \sqrt{\frac{4P_s}{\pi \tau n}}$$

**3. Combined tension and shear stress.** When the bolt is subjected to both tension and shear loads, as in case of coupling bolts or bearing, then the diameter of the shank of the bolt is obtained from the shear load and that of threaded part from the tensile load. A diameter slightly larger than that required for either shear or tension may be assumed and stresses due to combined load should be checked for the following principal stresses.

Maximum principal shear stress,

$$\tau_{max} = \frac{1}{2} \sqrt{(\sigma_t)^2 + 4\tau^2}$$

And maximum principal tensile stress,

$$\sigma_{t(max)} = \frac{\sigma_t}{2} + \frac{1}{2} \sqrt{(\sigma_t)^2 + 4\tau^2}$$



These stresses should not exceed the safe permissible values of stresses.

**References:**

1. Machine Design - V.Bandari .
2. Machine Design – R.S. Khurmi
3. Design Data hand Book - S MD Jalaludin.

Contents: Stresses due to combined loading and design of cylindrical cover plates.

**Stress due to Combined Forces**

The resultant axial load on a bolt depends upon the following factors:

1. The initial tension due to tightening of the bolt,
2. The external load, and
3. The relative elastic yielding (springiness) of the bolt and the connected members.

When the connected members are very yielding as compared with the bolt, which is a soft gasket, as shown in Fig. 1 (a), then the resultant load on the bolt is approximately equal to the sum of the initial tension and the external load. On the other hand, if the bolt is very yielding as compared with the connected members, as shown in Fig. 1(b), then the resultant load will be either the initial tension or the external load, whichever is greater. The actual conditions usually lie between the two extremes. In order to determine the resultant axial load (*P*) on the bolt, the following equation may be used :

$$P = P_1 + \frac{a}{1+a} \times P_2 = P_1 + K.P_2 \quad \dots \left( \text{Substituting } \frac{a}{1+a} = K \right)$$

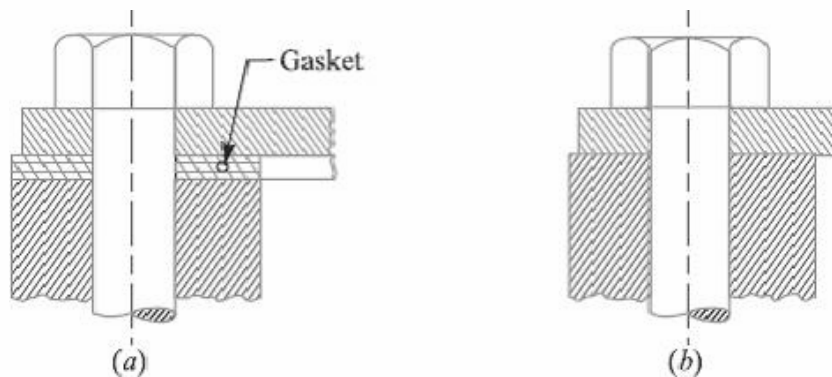

Fig.1

Where  $P_1$  = Initial tension due to tightening of the bolt,

$P_2$  = External load on the bolt, and

$a$  = Ratio of elasticity of connected parts to the elasticity of bolt.

For soft gaskets and large bolts, the value of  $a$  is high and the value of  $a / (1+a)$  is approximately equal to unity, so that the resultant load is equal to the sum of the initial tension and the external load. For hard gaskets or metal to metal contact surfaces and with small bolts, the value of  $a$  is small and the resultant load is mainly due to the initial tension (or external load, in rare case it is greater than initial tension). The value of 'a' may be estimated by the designer to obtain an approximate value for the resultant load. The values of

$a/(1+a)$  (i.e.  $K$ ) for various type of joints are shown in the following table. The designer thus has control over the influence on the resultant load on a bolt by proportioning the sizes of the connected parts and bolts and by specifying initial tension in the bolt.

Values of  $K$  for various types of joints.

Type of joint	$K = \frac{a}{1+a}$
Metal to metal joint with through bolts	0.00 to 0.10
Hard copper gasket with long through bolts	0.25 to 0.50
Soft copper gasket with long through bolts	0.50 to 0.75
Soft packing with through bolts	0.75 to 1.00
Soft packing with studs	1.00

### **Design of Cylinder Covers**

The cylinder covers may be secured by means of bolts or studs, but studs are preferred. The possible arrangement of securing the cover with bolts and studs is shown in Fig. 2 (a) and (b) respectively. The bolts or studs, cylinder cover plate and cylinder flange may be designed as discussed below:

#### ***1. Design of bolts or studs***

In order to find the size and number of bolts or studs, the following procedure may be adopted.

Let  $D$  = Diameter of the cylinder,

$p$  = Pressure in the cylinder,

$d_c$  = Core diameter of the bolts or studs,

$n$  = Number of bolts or studs, and

$\sigma_{tb}$  = Permissible tensile stress for the bolt or stud material.

We know that upward force acting on the cylinder cover,

$$P = \frac{\pi}{4} (D^2) p \quad \dots(i)$$

This force is resisted by  $n$  number of bolts or studs provided on the cover.

Resisting force offered by  $n$  number of bolts or studs,

$$P = \frac{\pi}{4} (d_c)^2 \sigma_{tb} \times n \quad \dots(ii)$$

From equations (i) and (ii), we have

$$\frac{\pi}{4} (D^2) p = \frac{\pi}{4} (d_c)^2 \sigma_{tb} \times n \quad \dots(ii)$$

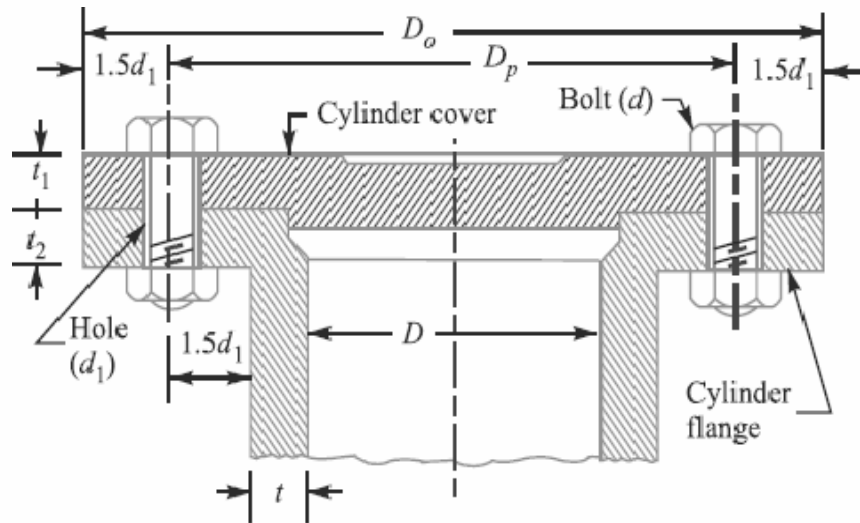

(a) Arrangement of securing the cylinder cover with bolts.

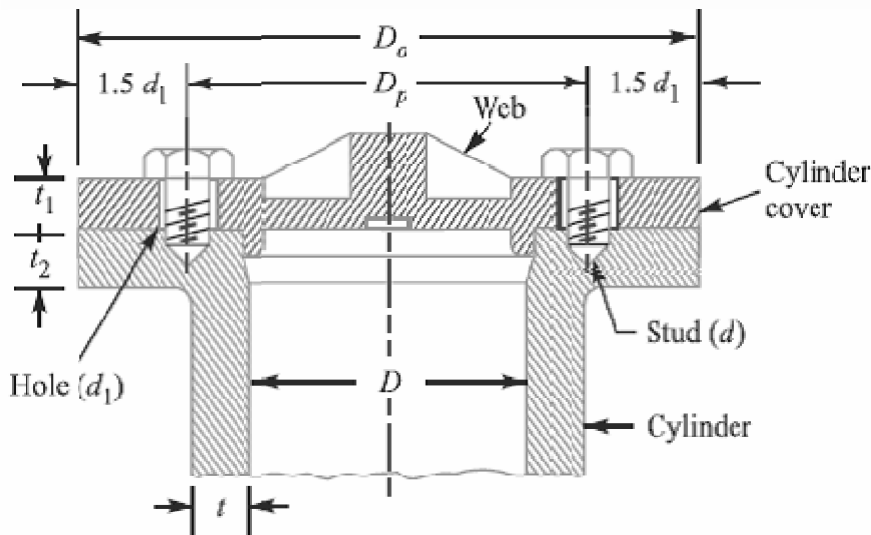

Fig. 2.

From this equation, the number of bolts or studs may be obtained, if the size of the bolt or stud is known and *vice-versa*. Usually the size of the bolt is assumed. If the value of  $n$  as obtained from the above relation is odd or a fraction, then next higher even number is adopted. The bolts or studs are screwed up tightly, along with metal gasket or asbestos packing, in order to provide a leak proof joint. We have already discussed that due to the tightening of bolts, sufficient tensile stress is produced in the bolts or studs. This may break the bolts or studs, even before any load due to internal pressure acts upon them. Therefore, a bolt or a stud less than 16 mm diameter should never be used.

The tightness of the joint also depends upon the circumferential pitch of the bolts or studs. The circumferential pitch should be between  $20 d_1$  and  $30 d_1$ , where  $d_1$  is the diameter of the hole in mm for bolt or stud. The pitch circle diameter ( $D_p$ ) is usually taken as  $D + 2t + 3d_1$  and outside diameter of the cover is kept as

$$D_0 = D_p + 3d_1 = D + 2t + 6d_1$$

where  $t$  = Thickness of the cylinder wall.

## 2. Design of cylinder cover plate

The thickness of the cylinder cover plate ( $t_1$ ) and the thickness of the cylinder flange ( $t_2$ ) may be determined as discussed below:

Let us consider the semi-cover plate as shown in Fig. 3. The internal pressure in the cylinder tries to lift the cylinder cover while the bolts or studs try to retain it in its position. But the centres of pressure of these two loads do not coincide. Hence, the cover plate is subjected to bending stress. The point X is the centre of pressure for bolt load and the point Y is the centre of internal pressure.

We know that the bending moment at A-A,

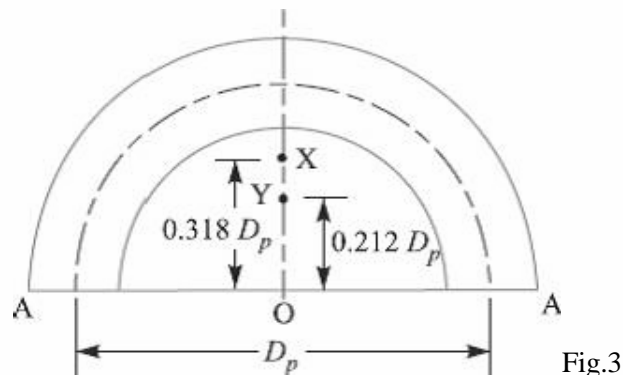

$$\begin{aligned}
 M &= \frac{\text{Total bolt load}}{2} (OX - OY) = \frac{P}{2} (0.318 D_p - 0.212 D_p) \\
 &= \frac{P}{2} \times 0.106 D_p = 0.053 P \times D_p \\
 Z &= \frac{1}{6} w (t_1)^2
 \end{aligned}$$

Where  $w$  = Width of plate

= Outside dia. of cover plate –  $2 \times$  dia. of bolt hole

$$= D_0 - 2d_1$$

Knowing the tensile stress for the cover plate material, the value of  $t_1$  may be determined by using the bending equation,

$$i.e., \sigma t = M / Z.$$

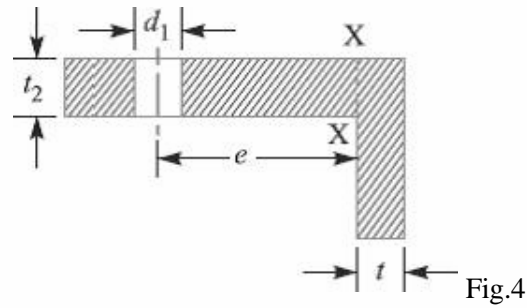

### 3. Design of cylinder flange

The thickness of the cylinder flange ( $t_2$ ) may be determined from bending consideration. A portion of the cylinder flange under the influence of one bolt is shown in Fig. 4. The load in the bolt produces bending stress in the section X-X. From the geometry of the figure, we find that eccentricity of the load from section X-X is

$$e = \text{Pitch circle radius} - (\text{Radius of bolt hole} + \text{Thickness of cylinder wall})$$

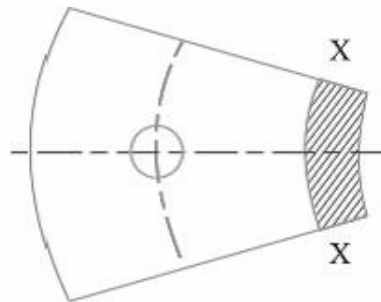

Fig.5

$$= \frac{D_p}{2} - \left( \frac{d_1}{2} + t \right)$$

Bending moment,  $M = \text{Load on each bolt} \times e$

$$= \frac{P}{n} \times e$$

$R = \text{Cylinder radius} + \text{Thickness of cylinder wall}$

$$= \frac{D}{2} + t$$

Width of the section X-X,

$$w = \frac{2\pi R}{n}, \text{ Where } n \text{ is the number of bolts.}$$

Section modulus,

$$Z = \frac{1}{6} w (t_2)^2$$

Knowing the tensile stress for the cylinder flange material, the value of  $t_2$  may be obtained by using the bending equation *i.e.*  $\sigma_t = M / Z$ .

**References:**

1. Machine Design - V.Bandari
2. Machine Design – R.S. Khurmi
3. Design Data hand Book - S MD Jalaludin.

## Problems on cylinder cover plate

Problem:

A steam engine cylinder has an effective diameter of 350 mm and the maximum steam pressure acting on the cylinder cover is  $1.25 \text{ N/mm}^2$ . Calculate the number and size of studs required to fix the cylinder cover, assuming the permissible stress in the studs as 33 MPa.

**Solution.** Given:  $D = 350 \text{ mm}$  ;  $p = 1.25 \text{ N/mm}^2$  ;  $\sigma_t = 33 \text{ MPa} = 33 \text{ N/mm}^2$

Let  $d$  = Nominal diameter of studs,  
 $d_c$  = Core diameter of studs, and  
 $n$  = Number of studs.

We know that the upward force acting on the cylinder cover,

$$P = \frac{\pi}{4} \times D^2 \times p = \frac{\pi}{4} (350)^2 \times 1.25 = 120\,265 \text{ N} \quad \dots(i)$$

Assume that the studs of nominal diameter 24 mm are used. From Table 11.1 (coarse series), we find that the corresponding core diameter ( $d_c$ ) of the stud is 20.32 mm.

$\therefore$  Resisting force offered by  $n$  number of studs,

$$P = \frac{\pi}{4} \times (d_c)^2 \times \sigma_t \times n = \frac{\pi}{4} (20.32)^2 \times 33 \times n = 10\,700 \text{ n N} \quad \dots(ii)$$

From equations (i) and (ii), we get

$$n = 120\,265 / 10\,700 = 11.24 \text{ say } 12 \text{ Ans.}$$

Taking the diameter of the stud hole ( $d_1$ ) as 25 mm, we have pitch circle diameter of the studs,

$$D_p = D_1 + 2t + 3d_1 = 350 + 2 \times 10 + 3 \times 25 = 445 \text{ mm}$$

...(Assuming  $t = 10 \text{ mm}$ )

$\therefore$  \*Circumferential pitch of the studs

$$= \frac{\pi \times D_p}{n} = \frac{\pi \times 445}{12} = 116.5 \text{ mm}$$

We know that for a leak-proof joint, the circumferential pitch of the studs should be between  $20\sqrt{d_1}$  to  $30\sqrt{d_1}$ , where  $d_1$  is the diameter of stud hole in mm.

$\therefore$  Minimum circumferential pitch of the studs

$$= 20\sqrt{d_1} = 20\sqrt{25} = 100 \text{ mm}$$

and maximum circumferential pitch of the studs

$$= 30\sqrt{d_1} = 30\sqrt{25} = 150 \text{ mm}$$

Since the circumferential pitch of the studs obtained above lies within 100 mm to 150 mm, therefore the size of the bolt chosen is satisfactory.

$\therefore$  Size of the bolt = M 24 Ans.



Problem:

A mild steel cover plate is to be designed for an inspection hole in the shell of a pressure vessel. The hole is 120 mm in diameter and the pressure inside the vessel is  $6 \text{ N/mm}^2$ . Design the cover plate along with the bolts. Assume allowable tensile stress for mild steel as 60 MPa and for bolt material as 40 MPa.

**Solution.** Given :  $D = 120 \text{ mm}$  or  $r = 60 \text{ mm}$  ;  $p = 6 \text{ N/mm}^2$  ;  $\sigma_t = 60 \text{ MPa} = 60 \text{ N/mm}^2$  ;  
 $\sigma_{tb} = 40 \text{ MPa} = 40 \text{ N/mm}^2$

First for all, let us find the thickness of the pressure vessel. According to Lamé's equation, thickness of the pressure vessel,

$$t = r \left[ \sqrt{\frac{\sigma_t + p}{\sigma_t - p}} - 1 \right] = 60 \left[ \sqrt{\frac{60 + 6}{60 - 6}} - 1 \right] = 6 \text{ mm}$$

Let us adopt  $t = 10 \text{ mm}$

*Design of bolts*

Let  $d$  = Nominal diameter of the bolts,  
 $d_c$  = Core diameter of the bolts, and  
 $n$  = Number of bolts.

We know that the total upward force acting on the cover plate (or on the bolts),

$$P = \frac{\pi}{4} (D)^2 p = \frac{\pi}{4} (120)^2 6 = 67\,867 \text{ N} \quad \dots(i)$$

Let the nominal diameter of the bolt is 24 mm. From Table 11.1 (coarse series), we find that the corresponding core diameter ( $d_c$ ) of the bolt is 20.32 mm.

$\therefore$  Resisting force offered by  $n$  number of bolts,

$$P = \frac{\pi}{4} (d_c)^2 \sigma_{tb} \times n = \frac{\pi}{4} (20.32)^2 40 \times n = 67\,867 \text{ N} = 12\,973 n \text{ N} \quad \dots(ii)$$

From equations (i) and (ii), we get

$$n = 67\,867 / 12\,973 = 5.23 \text{ say } 6$$

Taking the diameter of the bolt hole ( $d_1$ ) as 25 mm, we have pitch circle diameter of bolts,

$$D_p = D + 2t + 3d_1 = 120 + 2 \times 10 + 3 \times 25 = 215 \text{ mm}$$

$\therefore$  Circumferential pitch of the bolts

$$= \frac{\pi \times D_p}{n} = \frac{\pi \times 215}{6} = 112.6 \text{ mm}$$

We know that for a leak proof joint, the circumferential pitch of the bolts should lie between  $20\sqrt{d_1}$  to  $30\sqrt{d_1}$ , where  $d_1$  is the diameter of the bolt hole in mm.

$\therefore$  Minimum circumferential pitch of the bolts

$$= 20\sqrt{d_1} = 20\sqrt{25} = 100 \text{ mm}$$

and maximum circumferential pitch of the bolts

$$= 30\sqrt{d_1} = 30\sqrt{25} = 150 \text{ mm}$$

Since the circumferential pitch of the bolts obtained above is within 100 mm and 150 mm, therefore size of the bolt chosen is satisfactory.

∴ Size of the bolt = M 24 Ans.

#### *Design of cover plate*

Let  $t_1$  = Thickness of the cover plate.

The semi-cover plate is shown in Fig. 11.27.

We know that the bending moment at A-A,

$$\begin{aligned} M &= 0.053 P \times D_p \\ &= 0.053 \times 67\,860 \times 215 \\ &= 773\,265 \text{ N-mm} \end{aligned}$$

Outside diameter of the cover plate,

$$D_o = D_p + 3d_1 = 215 + 3 \times 25 = 290 \text{ mm}$$

Width of the plate,

$$w = D_o - 2d_1 = 290 - 2 \times 25 = 240 \text{ mm}$$

∴ Section modulus,

$$Z = \frac{1}{6} w (t_1)^2 = \frac{1}{6} \times 240 (t_1)^2 = 40 (t_1)^2 \text{ mm}^3$$

We know that bending (tensile) stress,

$$\sigma_t = M/Z \quad \text{or} \quad 60 = 773\,265 / 40 (t_1)^2$$

∴  $(t_1)^2 = 773\,265 / 40 \times 60 = 322 \quad \text{or} \quad t_1 = 18 \text{ mm Ans.}$

#### **References:**

1. Machine Design - V.Bandari .
2. Machine Design – R.S. Khurmi
3. Design Data hand Book - S MD Jalaludin.

## Lecture Notes – 43

Contents: Design of bolted joints under eccentric loading-1

**Eccentric Load Acting Parallel to the Axis of Bolts**

Consider a bracket having a rectangular base bolted to a wall by means of four bolts as shown in Fig.1. A little consideration will show that each bolt is subjected to a direct tensile load of

$$W_{f1} = \frac{W}{n}, \text{ where } n \text{ is the number of bolts.}$$

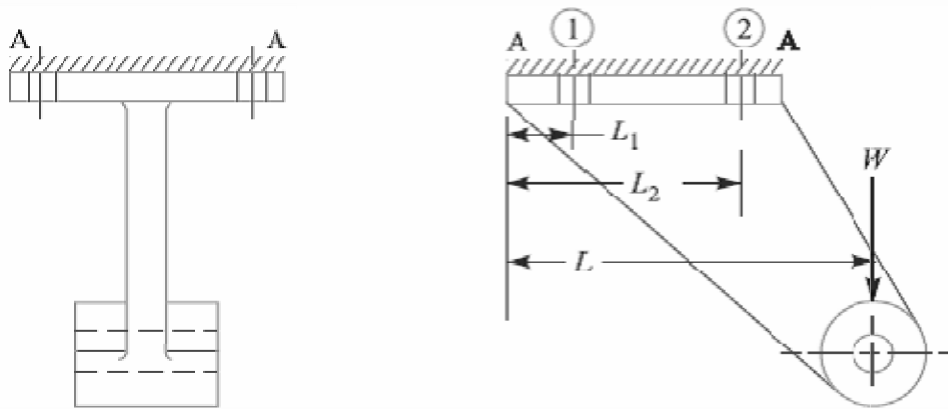

Fig.1. Eccentric load acting parallel to the axis of bolts.

Further the load  $W$  tends to rotate the bracket about the edge A-A. Due to this, each bolt is stretched by an amount that depends upon its distance from the tilting edge. Since the stress is a function of elongation, therefore each bolt will experience a different load which also depends upon the distance from the tilting edge. For convenience, all the bolts are made of same size. In case the flange is heavy, it may be considered as a rigid body.

Let  $w$  be the load in a bolt per unit distance due to the turning effect of the bracket and let  $W_1$  and  $W_2$  be the loads on each of the bolts at distances  $L_1$  and  $L_2$  from the tilting edge.

Load on each bolt at distance  $L_1$ ,

$$W_1 = w.L_1$$

And moment of this load about the tilting edge

$$= w.L_1 \times L_1 = w (L_1)^2$$

Similarly, load on each bolt at distance  $L_2$ ,

$$W_2 = w.L_2$$

And moment of this load about the tilting edge

$$= w.L_2 \times L_2 = w (L_2)^2$$

So, Total moment of the load on the bolts about the tilting edge

$$= 2w (L_1)^2 + 2w (L_2)^2 \dots(i)$$

... (Since, there are two bolts each at distance of  $L_1$  and  $L_2$ )

Also the moment due to load  $W$  about the tilting edge

$$= W.L \dots (ii)$$

From equations (i) and (ii), we have

$$W.L = 2w(L_1)^2 + 2w(L_2)^2 \quad \text{or} \quad w = \frac{W.L}{2[(L_1)^2 + (L_2)^2]} \quad \dots(iii)$$

It may be noted that the most heavily loaded bolts are those which are situated at the greatest distance from the tilting edge. In the case discussed above, the bolts at distance  $L_2$  are heavily loaded.

So, Tensile load on each bolt at distance  $L_2$ ,

$$W_{t2} = W_2 = w.L_2 = \frac{W.L.L_2}{2[(L_1)^2 + (L_2)^2]} \quad \dots [\text{From equation (iii)}]$$

And the total tensile load on the most heavily loaded bolt,

$$W_t = W_{t1} + W_{t2} \dots (iv)$$

If  $d_c$  is the core diameter of the bolt and  $\sigma_t$  is the tensile stress for the bolt material, then total tensile load,

$$W_t = \frac{\pi}{4} (d_c)^2 \sigma_t \quad \dots(v)$$

From equations (iv) and (v), the value of  $d_c$  may be obtained.

**Problem:**

A bracket, as shown in Fig.1, supports a load of 30 kN. Determine the size of bolts, if the maximum allowable tensile stress in the bolt material is 60 MPa. The distances are:  $L_1 = 80$  mm,  $L_2 = 250$  mm, and  $L = 500$  mm.

**Solution.** Given :  $W = 30$  kN ;  $\sigma_t = 60$  MPa = 60 N/mm<sup>2</sup> ;  $L_1 = 80$  mm ;  $L_2 = 250$  mm ;  $L = 500$  mm

We know that the direct tensile load carried by each bolt,

$$W_{t1} = \frac{W}{n} = \frac{30}{4} = 7.5 \text{ kN}$$

and load in a bolt per unit distance,

$$w = \frac{W.L}{2[(L_1)^2 + (L_2)^2]} = \frac{30 \times 500}{2[(80)^2 + (250)^2]} = 0.109 \text{ kN/mm}$$

Since the heavily loaded bolt is at a distance of  $L_2$  mm from the tilting edge, therefore load on the heavily loaded bolt,

$$W_{l2} = wL_2 = 0.109 \times 250 = 27.25 \text{ kN}$$

∴ Maximum tensile load on the heavily loaded bolt,

$$W_t = W_{t1} + W_{l2} = 7.5 + 27.25 = 34.75 \text{ kN} = 34\,750 \text{ N}$$

Let  $d_c$  = Core diameter of the bolts.

We know that the maximum tensile load on the bolt ( $W_t$ ),

$$34\,750 = \frac{\pi}{4} (d_c)^2 \sigma_t = \frac{\pi}{4} (d_c)^2 60 = 47 (d_c)^2$$

$$\therefore (d_c)^2 = 34\,750 / 47 = 740$$

or  $d_c = 27.2 \text{ mm}$

From DDB (coarse series), we find that the standard core diameter of the bolt is 28.706 mm and the corresponding size of the bolt is M 33. **Ans.**

**References:**

1. Machine Design - V.Bandari .
2. Machine Design – R.S. Khurmi
3. Design Data hand Book - S MD Jalaludin.

### Eccentric Load Acting Perpendicular to the Axis of Bolts

A wall bracket carrying an eccentric load perpendicular to the axis of the bolts is shown in Fig.2.

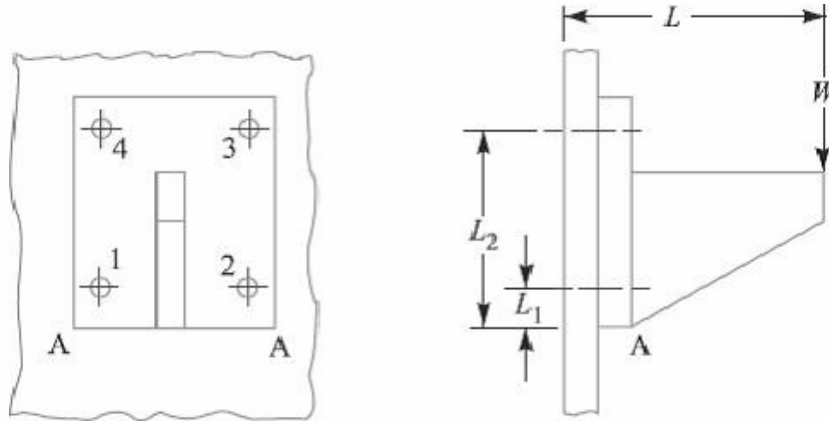

Fig. 2. Eccentric load perpendicular to the axis of bolts.

In this case, the bolts are subjected to direct shearing load which is equally shared by all the bolts. Therefore direct shear load on each bolts,

$$W_s = W/n, \text{ where } n \text{ is number of bolts.}$$

A little consideration will show that the eccentric load  $W$  will try to tilt the bracket in the clockwise direction about the edge  $A-A$ . As discussed earlier, the bolts will be subjected to tensile stress due to the turning moment. The maximum tensile load on a heavily loaded bolt ( $W_t$ ) may be obtained in the similar manner as discussed in the previous article. In this case, bolts 3 and 4 are heavily loaded.

Maximum tensile load on bolt 3 or 4,

$$W_{t2} = W_t = \frac{W.L.L_2}{2 [(L_1)^2 + (L_2)^2]}$$

When the bolts are subjected to shear as well as tensile loads, then the equivalent loads may be determined by the following relations:

Equivalent tensile load,

$$W_{te} = \frac{1}{2} \left[ W_t + \sqrt{(W_t)^2 + 4(W_s)^2} \right]$$

And equivalent shear load,

$$W_{se} = \frac{1}{2} \left[ \sqrt{(W_t)^2 + 4(W_s)^2} \right]$$

Knowing the value of equivalent loads, the size of the bolt may be determined for the given allowable stresses.

Problem:

For supporting the travelling crane in a workshop, the brackets are fixed on steel columns as shown in Fig. The maximum load that comes on the bracket is 12 kN acting vertically at a distance of 400 mm from the face of the column. The vertical face of the bracket is secured to a column by four bolts, in two rows (two in each row) at a distance of 50 mm from the lower edge of the bracket. Determine the size of the bolts if the permissible value of the tensile stress for the bolt material is 84 MPa. Also find the cross-section of the arm of the bracket which is rectangular.

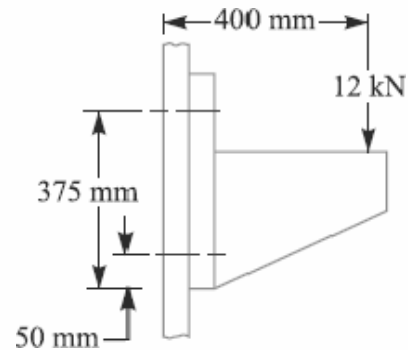

**Solution.** Given :  $W = 12 \text{ kN} = 12 \times 10^3 \text{ N}$  ;  $L = 400 \text{ mm}$  ;  
 $L_1 = 50 \text{ mm}$  ;  $L_2 = 375 \text{ mm}$  ;  $\sigma_t = 84 \text{ MPa} = 84 \text{ N/mm}^2$  ;  $n = 4$   
 We know that direct shear load on each bolt,

$$W_s = \frac{W}{n} = \frac{12}{4} = 3 \text{ kN}$$

Since the load  $W$  will try to tilt the bracket in the clockwise direction about the lower edge, therefore the bolts will be subjected to tensile load due to turning moment. The maximum loaded bolts are 3 and 4 (See Fig.1), because they lie at the greatest distance from the tilting edge A-A (*i.e.* lower edge).

We know that maximum tensile load carried by bolts 3 and 4,

$$W_t = \frac{W.L.L_2}{2 [(L_1)^2 + (L_2)^2]} = \frac{12 \times 400 \times 375}{2 [(50)^2 + (375)^2]} = 6.29 \text{ kN}$$

Since the bolts are subjected to shear load as well as tensile load, therefore equivalent tensile load,

$$\begin{aligned} W_{te} &= \frac{1}{2} \left[ W_t + \sqrt{(W_t)^2 + 4(W_s)^2} \right] = \frac{1}{2} \left[ 6.29 + \sqrt{(6.29)^2 + 4 \times 3^2} \right] \text{ kN} \\ &= \frac{1}{2} (6.29 + 8.69) = 7.49 \text{ kN} = 7490 \text{ N} \end{aligned}$$

### Size of the bolt

Let  $d_c$  = Core diameter of the bolt.

We know that the equivalent tensile load ( $W_{te}$ ),

$$7490 = \frac{\pi}{4} (d_c)^2 \sigma_t = \frac{\pi}{4} (d_c)^2 84 = 66 (d_c)^2$$

$$\therefore (d_c)^2 = 7490 / 66 = 113.5 \quad \text{or} \quad d_c = 10.65 \text{ mm}$$

From Table 11.1 (coarse series), the standard core diameter is 11.546 mm and the corresponding size of the bolt is M 14. **Ans.**

### Cross-section of the arm of the bracket

Let  $t$  and  $b$  = Thickness and depth of arm of the bracket respectively.

$\therefore$  Section modulus,

$$Z = \frac{1}{6} t b^2$$

Assume that the arm of the bracket extends upto the face of the steel column. This assumption gives stronger section for the arm of the bracket.

$\therefore$  Maximum bending moment on the bracket,

$$M = 12 \times 10^3 \times 400 = 4.8 \times 10^6 \text{ N-mm}$$

We know that the bending (tensile) stress ( $\sigma_t$ ),

$$84 = \frac{M}{Z} = \frac{4.8 \times 10^6 \times 6}{t b^2} = \frac{28.8 \times 10^6}{t b^2}$$

$$\therefore t b^2 = 28.8 \times 10^6 / 84 = 343 \times 10^3 \quad \text{or} \quad t = 343 \times 10^3 / b^2$$

Assuming depth of arm of the bracket,  $b = 250$  mm, we have

$$t = 343 \times 10^3 / (250)^2 = 5.5 \text{ mm Ans.}$$

### References:

1. Machine Design - V. Bandari .
2. Machine Design – R.S. Khurmi
3. Design Data hand Book - S MD Jalaludin.



### Eccentric Load on a Bracket with Circular Base

Sometimes the base of a bracket is made circular as in case of a flanged bearing of a heavy machine tool and pillar crane etc. Consider a round flange bearing of a machine tool having four bolts as shown in Fig. 1.

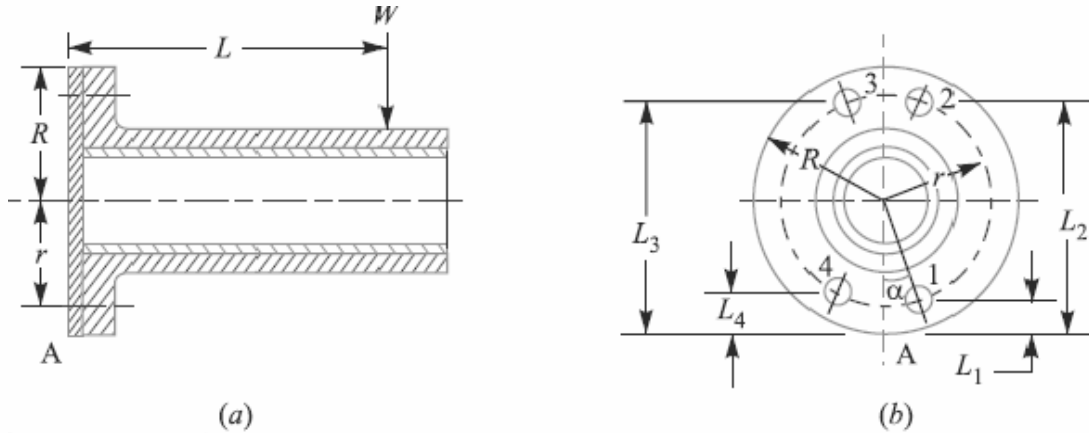

Fig.1. Eccentric load on a bracket with circular base.

- Let  $R$  = Radius of the column flange,  
 $r$  = Radius of the bolt pitch circle,  
 $w$  = Load per bolt per unit distance from the tilting edge,  
 $L$  = Distance of the load from the tilting edge, and  
 $L_1, L_2, L_3,$  and  $L_4$  = Distance of bolt centers from the tilting edge A.

As discussed in the previous article, equating the external moment  $W \times L$  to the sum of the resisting moments of all the bolts, we have,

$$WL = w [(L_1)^2 + (L_2)^2 + (L_3)^2 + (L_4)^2]$$

$$\therefore w = \frac{WL}{(L_1)^2 + (L_2)^2 + (L_3)^2 + (L_4)^2} \quad \dots(i)$$

Now from the geometry of the Fig. 1(b), we find that

$$L_1 = R - r \cos \alpha \quad L_2 = R + r \sin \alpha$$

$$L_3 = R + r \cos \alpha \quad \text{and} \quad L_4 = R - r \sin \alpha$$

Substituting these values in equation (i), we get

$$w = \frac{WL}{4R^2 + 2r^2}$$

Load in the bolt situated at 1 =  $w.L_1$  =

$$\frac{W.L.L_1}{4R^2 + 2r^2} = \frac{W.L(R - r \cos \alpha)}{4R^2 + 2r^2}$$

This load will be maximum when  $\cos \alpha$  is minimum *i.e.* when  $\cos \alpha = -1$  or  $\alpha = 180^\circ$ .

Maximum load in a bolt

$$= \frac{W.L(R+r)}{4R^2+2r^2}$$

In general, if there are  $n$  number of bolts, then load in a bolt

$$= \frac{2W.L(R-r\cos\alpha)}{n(2R^2+r^2)}$$

And maximum load in a bolt,

$$W_t = \frac{2W.L(R+r)}{n(2R^2+r^2)}$$

The above relation is used when the direction of the load  $W$  changes with relation to the bolts as in the case of pillar crane. But if the direction of load is fixed, then the maximum load on the bolts may be reduced by locating the bolts in such a way that two of them are equally stressed as shown in Fig.2. In such a case, maximum load is given by

$$W_t = \frac{2W.L}{n} \left[ \frac{R+r\cos\left(\frac{180}{n}\right)}{2R^2+r^2} \right]$$

Knowing the value of maximum load, we can determine the size of the bolt.

**Note:** Generally, two dowel pins as shown in Fig. 2, are used to take up the shear load. Thus the bolts are relieved of shear stress and the bolts are designed for tensile load only.

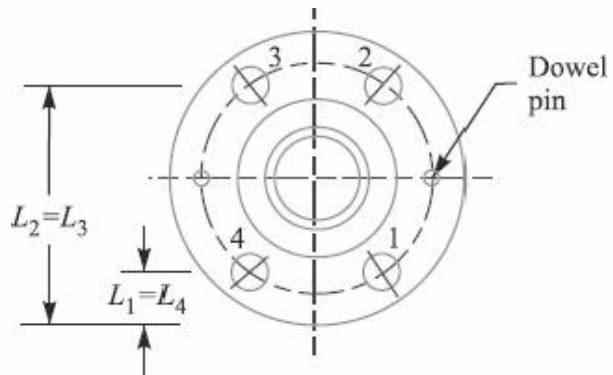

Fig.2.

Problem:

A flanged bearing, as shown in Fig.1, is fastened to a frame by means of four bolts spaced equally on 500 mm bolt circle. The diameter of bearing flange is 650 mm and a load of 400 kN acts at a distance of 250 mm from the frame. Determine the size of the bolts, taking safe tensile stress as 60 MPa for the material of the bolts.

**Solution.** Given :  $n = 4$  ;  $d = 500$  mm or  $r = 250$  mm ;  $D = 650$  mm or  $R = 325$  mm ;  $W = 400$  kN =  $400 \times 10^3$  N ;  $L = 250$  mm ;  $\sigma_t = 60$  MPa =  $60$  N/mm<sup>2</sup>

Let  $d_c =$  Core diameter of the bolts.

We know that when the bolts are equally spaced, the maximum load on the bolt,

$$W_t = \frac{2WL}{n} \left[ \frac{R + r \cos\left(\frac{180}{n}\right)}{2R^2 + r^2} \right]$$

$$= \frac{2 \times 400 \times 10^3 \times 250}{4} \left[ \frac{325 + 250 \cos\left(\frac{180}{4}\right)}{2(325)^2 + (250)^2} \right] = 91\,643 \text{ N}$$

We also know that maximum load on the bolt ( $W_t$ ),

$$91\,643 = \frac{\pi}{4} (d_c)^2 \sigma_t = \frac{\pi}{4} (d_c)^2 60 = 47.13 (d_c)^2$$

$$\therefore (d_c)^2 = 91\,643 / 47.13 = 1945 \quad \text{or} \quad d_c = 44 \text{ mm}$$

From DDB, we find that the standard core diameter of the bolt is 45.795 mm and corresponding size of the bolt is M 52.

**Ans.**

**References:**

1. Machine Design - V. Bandari .
2. Machine Design – R.S. Khurmi
3. Design Data hand Book - S MD Jalaludin.

**Eccentric Load Acting in the Plane Containing the Bolts**

When the eccentric load acts in the plane containing the bolts, as shown in Fig.1, then the same procedure may be followed as discussed for eccentric loaded riveted joints.

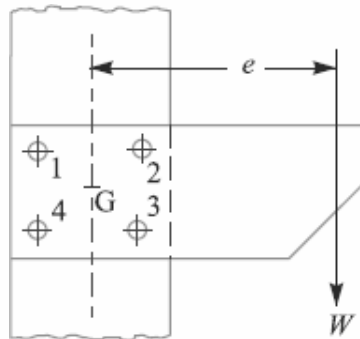

Fig. 1. Eccentric load in the plane containing the bolts.

Problem:

Fig.2 shows a solid forged bracket to carry a vertical load of 13.5 kN applied through the centre of hole. The square flange is secured to the flat side of a vertical stanchion through four bolts. Calculate suitable diameter  $D$  and  $d$  for the arms of the bracket, if the permissible stresses are 110 MPa in tension and 65 MPa in shear. Estimate also the tensile load on each top bolt and the maximum shearing force on each bolt.

**Solution.** Given :  $W = 13.5 \text{ kN} = 13\,500 \text{ N}$  ;  $\sigma_t = 110 \text{ MPa} = 110 \text{ N/mm}^2$  ;  $\tau = 65 \text{ MPa} = 65 \text{ N/mm}^2$

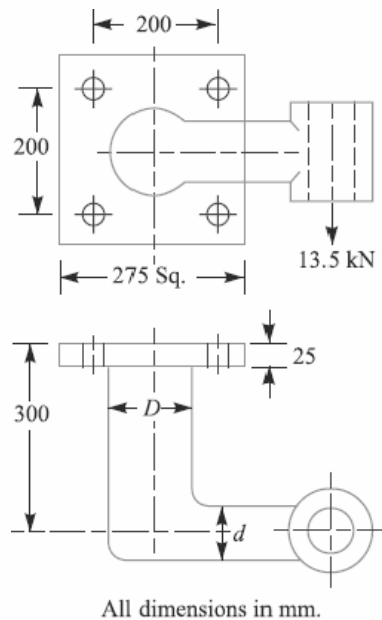

Fig.2

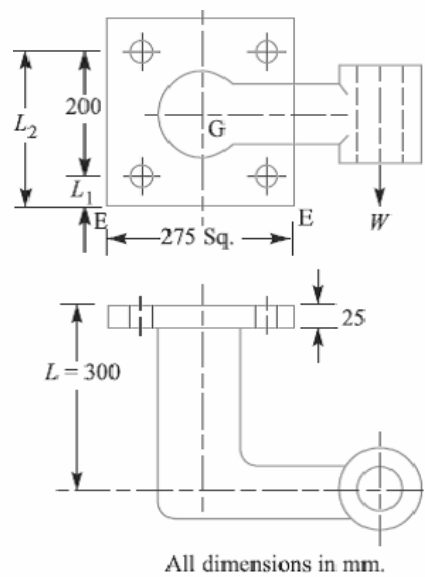

Fig.3

*Diameter D for the arm of the bracket*

The section of the arm having  $D$  as the diameter is subjected to bending moment as well as twisting moment. We know that bending moment,

$$M = 13\,500 \times (300 - 25) = 3712.5 \times 10^3 \text{ N-mm}$$

and twisting moment,  $T = 13\,500 \times 250 = 3375 \times 10^3 \text{ N-mm}$

$\therefore$  Equivalent twisting moment,

$$\begin{aligned} T_e &= \sqrt{M^2 + T^2} = \sqrt{(3712.5 \times 10^3)^2 + (3375 \times 10^3)^2} \text{ N-mm} \\ &= 5017 \times 10^3 \text{ N-mm} \end{aligned}$$

We know that equivalent twisting moment ( $T_e$ ),

$$5017 \times 10^3 = \frac{\pi}{16} \times \tau \times D^3 = \frac{\pi}{16} \times 65 \times D^3 = 12.76 D^3$$

$$\therefore D^3 = 5017 \times 10^3 / 12.76 = 393 \times 10^3$$

or  $D = 73.24$  say **75 mm Ans.**

*Diameter (d) for the arm of the bracket*

The section of the arm having  $d$  as the diameter is subjected to bending moment only. We know that bending moment,

$$M = 13\,500 \left( 250 - \frac{75}{2} \right) = 2868.8 \times 10^3 \text{ N-mm}$$

and section modulus,  $Z = \frac{\pi}{32} \times d^3 = 0.0982 d^3$

We know that bending (tensile) stress ( $\sigma_t$ ),

$$110 = \frac{M}{Z} = \frac{2868.8 \times 10^3}{0.0982 d^3} = \frac{29.2 \times 10^6}{d^3}$$

$$\therefore d^3 = 29.2 \times 10^6 / 110 = 265.5 \times 10^3 \quad \text{or} \quad d = 64.3 \text{ say } 65 \text{ mm Ans.}$$

*Tensile load on each top bolt*

Due to the eccentric load  $W$ , the bracket has a tendency to tilt about the edge  $E-E$ , as shown in Fig. 11.46.

Let  $w$  = Load on each bolt per mm distance from the tilting edge due to the tilting effect of the bracket.

Since there are two bolts each at distance  $L_1$  and  $L_2$  as shown in Fig. 11.46, therefore total moment of the load on the bolts about the tilting edge  $E-E$

$$\begin{aligned} &= 2(wL_1)L_1 + 2(wL_2)L_2 = 2w[(L_1)^2 + (L_2)^2] \\ &= 2w[(37.5)^2 + (237.5)^2] = 115\,625 w \text{ N-mm} \end{aligned} \quad \dots(i)$$

$$\dots(\because L_1 = 37.5 \text{ mm and } L_2 = 237.5 \text{ mm})$$

and turning moment of the load about the tilting edge

$$= WL = 13\,500 \times 300 = 4050 \times 10^3 \text{ N-mm} \quad \dots(ii)$$

From equations (i) and (ii), we have

$$w = 4050 \times 10^3 / 115\,625 = 35.03 \text{ N/mm}$$

$\therefore$  Tensile load on each top bolt

$$= wL_2 = 35.03 \times 237.5 = 8320 \text{ N Ans.}$$

**Maximum shearing force on each bolt**

We know that primary shear load on each bolt acting vertically downwards,

$$W_{s1} = \frac{W}{n} = \frac{13\,500}{4} = 3375 \text{ N} \quad \dots(\because \text{No. of bolts, } n = 4)$$

Since all the bolts are at equal distances from the centre of gravity of the four bolts ( $G$ ), therefore the secondary shear load on each bolt is same.

Distance of each bolt from the centre of gravity ( $G$ ) of the bolts,

$$l_1 = l_2 = l_3 = l_4 = \sqrt{(100)^2 + (100)^2} = 141.4 \text{ mm}$$

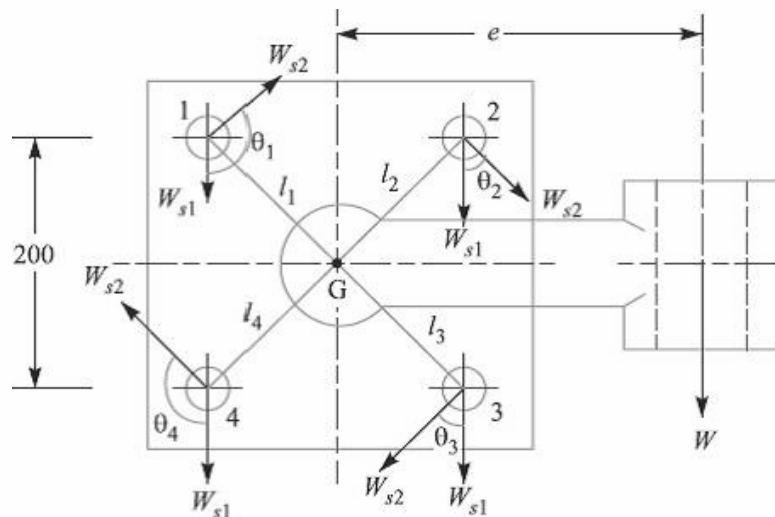

Fig.4

$\therefore$  Secondary shear load on each bolt,

$$W_{s2} = \frac{W \cdot e \cdot l_1}{(l_1)^2 + (l_2)^2 + (l_3)^2 + (l_4)^2} = \frac{13\,500 \times 250 \times 141.4}{4 (141.4)^2} = 5967 \text{ N}$$

Since the secondary shear load acts at right angles to the line joining the centre of gravity of the bolt group to the centre of the bolt as shown in Fig. 4, therefore the resultant of the primary and secondary shear load on each bolt gives the maximum shearing force on each bolt. From the geometry of the Fig. 4, we find that

$$\theta_1 = \theta_4 = 135^\circ, \text{ and } \theta_2 = \theta_3 = 45^\circ$$

Maximum shearing force on the bolts 1 and 4

$$\begin{aligned} &= \sqrt{(W_{s1})^2 + (W_{s2})^2 + 2 W_{s1} \times W_{s2} \times \cos 135^\circ} \\ &= \sqrt{(3375)^2 + (5967)^2 - 2 \times 3375 \times 5967 \times 0.7071} = 4303 \text{ N Ans.} \end{aligned}$$

And maximum shearing force on the bolts 2 and 3

$$= \sqrt{(W_{s1})^2 + (W_{s2})^2 + 2 W_{s1} \times W_{s2} \times \cos 45^\circ}$$

$$= \sqrt{(3375)^2 + (5967)^2 + 2 \times 3375 \times 5967 \times 0.7071} = 8687 \text{ N Ans.}$$

**References:**

1. Machine Design - V.Bandari .
2. Machine Design – R.S. Khurmi
3. Design Data hand Book - S MD Jalaludin.

## UNIT 4

### Keys, Cotters , and Knuckle joints

#### Introduction

A key is a piece of mild steel inserted between the shaft and hub or boss of the pulley to connect these together in order to prevent relative motion between them. It is always inserted parallel to the axis of the shaft. Keys are used as temporary fastenings and are subjected to considerable crushing and shearing stresses. A keyway is a slot or recess in a shaft and hub of the pulley to accommodate a key.

#### Types of Keys

The following types of keys are important from the subject point of view :

1. Sunk keys, 2. Saddle keys, 3. Tangent keys, 4. Round keys, and 5. Splines.

#### Sunk Keys

The sunk keys are provided half in the keyway of the shaft and half in the keyway of the hub or boss of the pulley. The sunk keys are of the following types :

**1. Rectangular sunk key.** A rectangular sunk key is shown in Fig. The usual proportions of this key are :

Width of key,  $w = d / 4$  ; and thickness of key,  $t = 2w / 3 = d / 6$

where  $d$  = Diameter of the shaft or diameter of the hole in the hub.

The key has taper 1 in 100 on the top side only.

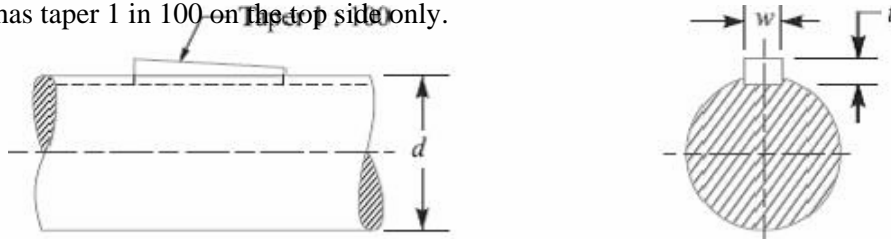

Fig. Sunk Key

**2. Square sunk key.** The only difference between a rectangular sunk key and a square sunk key is that its width and thickness are equal, i.e.  $w = t = d / 4$

**3. Parallel sunk key.** The parallel sunk keys may be of rectangular or square section uniform in width and thickness throughout. It may be noted that a parallel key is a taper less and is used where the pulley, gear or other mating piece is required to slide along the shaft.

**4. Gib-head key.** It is a rectangular sunk key with a head at one end known as **gib head**.

It is usually provided to facilitate the removal of key. A gib head key is shown in Fig.

(a) and its use in shown in Fig. (b).



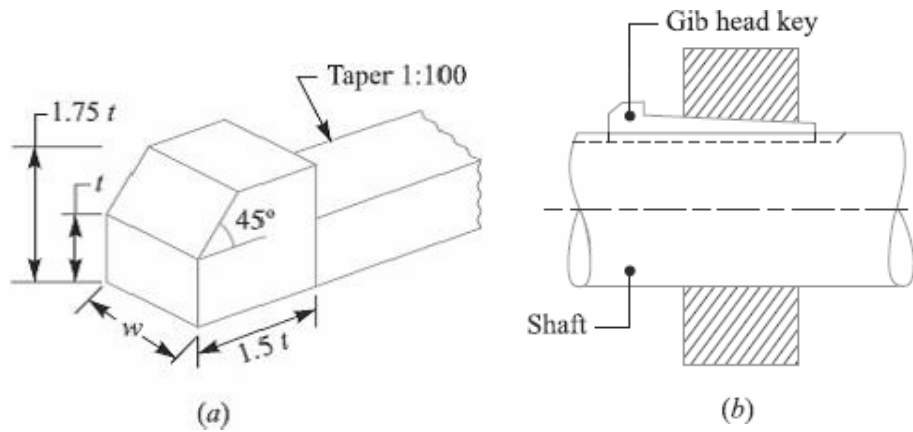

Fig. Gib head key and its use.

The usual proportions of the gib head key are:

Width,  $w = d / 4$  ; and thickness at large end,  $t = 2w / 3 = d / 6$

**5. Feather key.** A key attached to one member of a pair and which permits relative axial movement is known as **feather key**. It is a special type of parallel key which transmits a turning moment and also permits axial movement. It is fastened either to the shaft or hub, the key being a sliding fit in the key way of the moving piece.

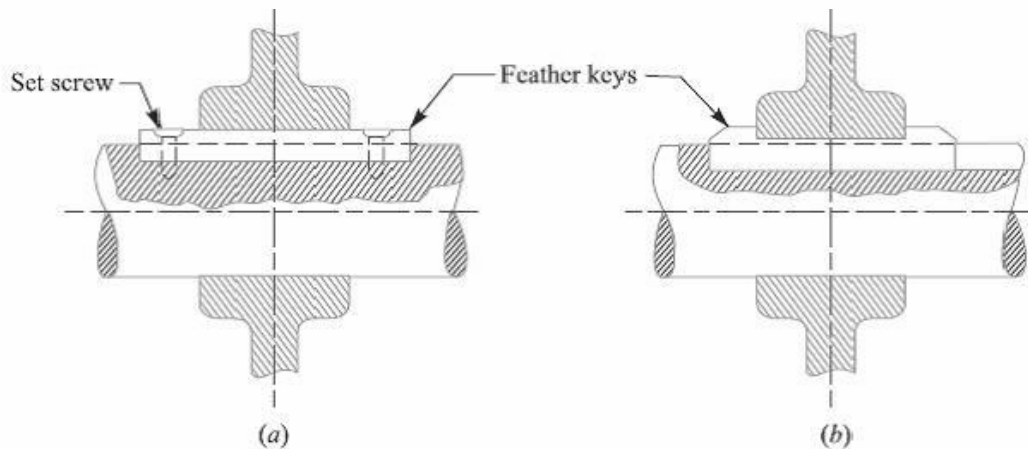

Fig. Feather Keys

**6. Woodruff key.** The woodruff key is an easily adjustable key. It is a piece from a cylindrical disc having segmental cross-section in front view as shown in Fig. A woodruff key is capable of tilting in a recess milled out in the shaft by a cutter having the same curvature as the disc from which the key is made. This key is largely used in machine tool and automobile construction.

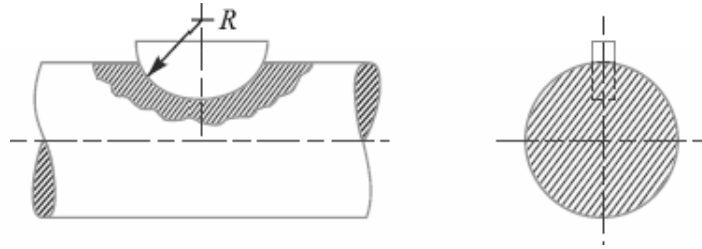

Fig. Woodruff Key

The main advantages of a woodruff key are as follows:

1. It accommodates itself to any taper in the hub or boss of the mating piece.
2. It is useful on tapering shaft ends. Its extra depth in the shaft prevents any tendency to turn over in its keyway.

The disadvantages are:

1. The depth of the keyway weakens the shaft.
2. It can not be used as a feather.

### Saddle keys

The saddle keys are of the following two types:

1. Flat saddle key, and 2. Hollow saddle key.

A **flat saddle key** is a taper key which fits in a keyway in the hub and is flat on the shaft as shown in Fig. It is likely to slip round the shaft under load. Therefore it is used for comparatively light loads.

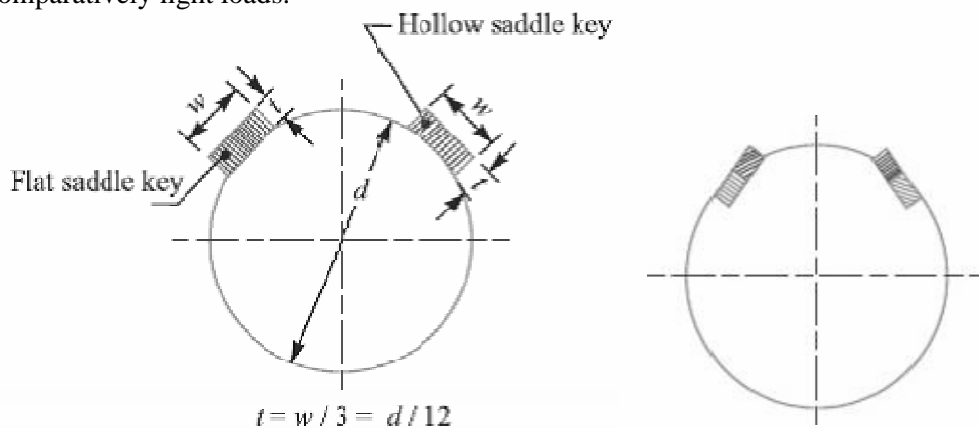

Fig. Flat saddle key and Tangent keys

A **hollow saddle key** is a taper key which fits in a keyway in the hub and the bottom of the key is shaped to fit the curved surface of the shaft. Since hollow saddle keys hold on by friction, therefore these are suitable for light loads. It is usually used as a temporary fastening in fixing and setting eccentrics, cams etc.

### Tangent Keys

The tangent keys are fitted in pair at right angles as shown in Fig. Each key is to withstand torsion in one direction only. These are used in large heavy duty shafts.

### Round Keys

The round keys, as shown in Fig. (a) are circular in section and fit into holes drilled partly in the shaft and partly in the hub. They have the advantage that their keyways may be drilled and reamed after the mating parts have been assembled. Round keys are usually considered to be most appropriate for low power drives.

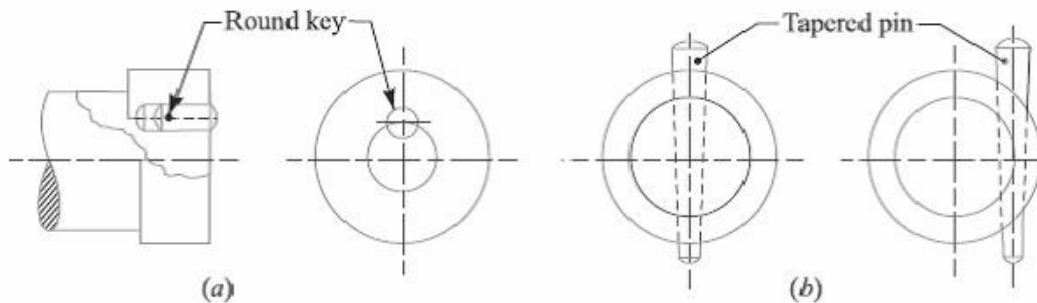

### Splines

Sometimes, keys are made integral with the shaft which fits into the keyways broached in the hub. Such shafts are known as **splined shafts** as shown in Fig. These shafts usually have six, ten or sixteen splines. The splined shafts are relatively stronger than shafts having a single keyway.

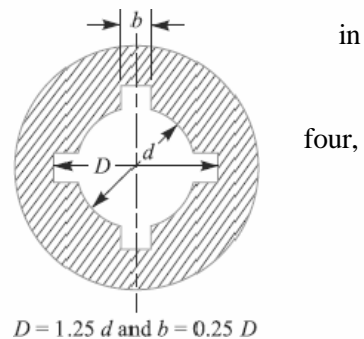

### Stresses in Keys:

#### Forces acting on a Sunk Key

When a key is used in transmitting torque from a shaft to a rotor or hub, the following two types of forces act on the key:

1. Forces ( $F_1$ ) due to fit of the key in its keyway, as in a tight fitting straight key or in a tapered key driven in place. These forces produce compressive stresses in the key which are difficult to determine in magnitude.
2. Forces ( $F$ ) due to the torque transmitted by the shaft. These forces produce shearing and compressive (or crushing) stresses in the key.

The forces acting on a key for a clockwise torque being transmitted from a shaft to a hub are shown in Fig.

In designing a key, forces due to fit of the key are neglected and it is assumed that the distribution of forces along the length of key is uniform.

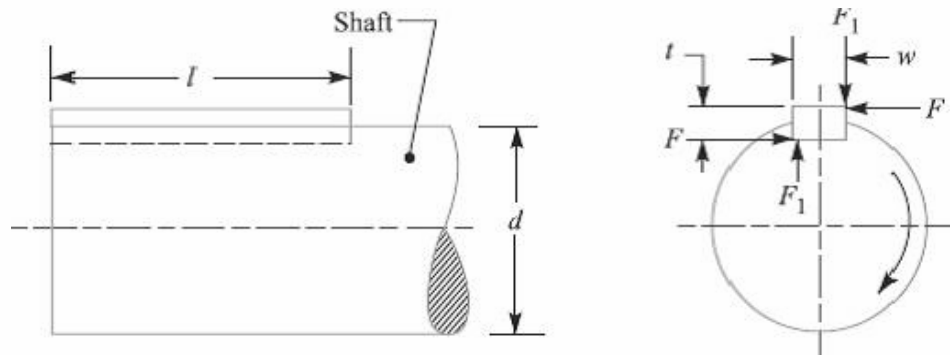

### **Strength of a Sunk Key**

A key connecting the shaft and hub is shown in Fig.

Let  $T$  = Torque transmitted by the shaft,

$F$  = Tangential force acting at the circumference of the shaft,

$d$  = Diameter of shaft,

$l$  = Length of key,

$w$  = Width of key.

$t$  = Thickness of key, and

$\tau$  and  $\sigma_c$  = Shear and crushing stresses for the material of key.

A little consideration will show that due to the power transmitted by the shaft, the key may fail due to shearing or crushing. Considering shearing of the key, the tangential shearing force acting at the circumference of the shaft,

$$F = \text{Area resisting shearing} \times \text{Shear stress} = l \times w \times \tau$$

Therefore, Torque transmitted by the shaft,

$$T = F \times \frac{d}{2} = l \times w \times \tau \times \frac{d}{2} \quad \dots(i)$$

Considering crushing of the key, the tangential crushing force acting at the circumference of the shaft,

$$F = \text{Area resisting crushing} \times \text{Crushing stress}$$

$$= l \times \frac{t}{2} \times \sigma_c$$

Therefore, Torque transmitted by the shaft,

$$T = F \times \frac{d}{2} = l \times \frac{t}{2} \times \sigma_c \times \frac{d}{2} \quad \dots(ii)$$

The key is equally strong in shearing and crushing, if

$$l \times w \times \tau \times \frac{d}{2} = l \times \frac{t}{2} \times \sigma_c \times \frac{d}{2}$$

Or

$$\frac{w}{t} = \frac{\sigma_c}{2\tau}$$

The permissible crushing stress for the usual key material is at least twice the permissible shearing stress. Therefore from the above equation, we have  $w = t$ . In other words, a square key is equally strong in shearing and crushing.

In order to find the length of the key to transmit full power of the shaft, the shearing strength of the key is equal to the torsional shear strength of the shaft. We know that the shearing strength of key,

$$T = l \times w \times \tau \times \frac{d}{2}$$

And torsional shear strength of the shaft,

$$T = \frac{\pi}{16} \times \tau_1 \times d^3$$

From the above

$$l \times w \times \tau \times \frac{d}{2} = \frac{\pi}{16} \times \tau_1 \times d^3$$

$$l = \frac{\pi}{8} \times \frac{\tau_1 d^2}{w \times \tau} = \frac{\pi d}{2} \times \frac{\tau_1}{\tau} = 1.571 d \times \frac{\tau_1}{\tau}$$

When the key material is same as that of the shaft, then  $\tau = \tau_1$ . So,  $l = 1.571 d$ .

### **References:**

1. Machine Design - V.Bandari .
2. Machine Design – R.S. Khurmi
3. Design Data hand Book - S MD Jalaludin.

### Cottered Joints:

A cotter is a flat wedge shaped piece of rectangular cross-section and its width is tapered (either on one side or both sides) from one end to another for an easy adjustment. The taper varies from 1 in 48 to 1 in 24 and it may be increased up to 1 in 8, if a locking device is provided. The locking device may be a taper pin or a set screw used on the lower end of the cotter. The cotter is usually made of mild steel or wrought iron. A cotter joint is a temporary fastening and is used to connect rigidly two co-axial rods or bars which are subjected to axial tensile or compressive forces. It is usually used in connecting a piston rod to the crosshead of a reciprocating steam engine, a piston rod and its extension as a tail or pump rod, strap end of connecting rod etc.

### Types of Cotter Joints

Following are the three commonly used cotter joints to connect two rods by a cotter:

1. Socket and spigot cotter joint,
2. Sleeve and cotter joint,
- and 3. Gib and cotter joint.

### Socket and Spigot Cotter Joint

In a socket and spigot cotter joint, one end of the rods (say *A*) is provided with a socket type of end as shown in Fig., and the other end of the other rod (say *B*) is inserted into a socket. The end of the rod which goes into a socket is also called *spigot*. A rectangular hole is made in the socket and spigot. A cotter is then driven tightly through a hole in order to make the temporary connection between the two rods. The load is usually acting axially, but it changes its direction and hence the cotter joint must be designed to carry both the tensile and compressive loads. The compressive load is taken up by the collar on the spigot.

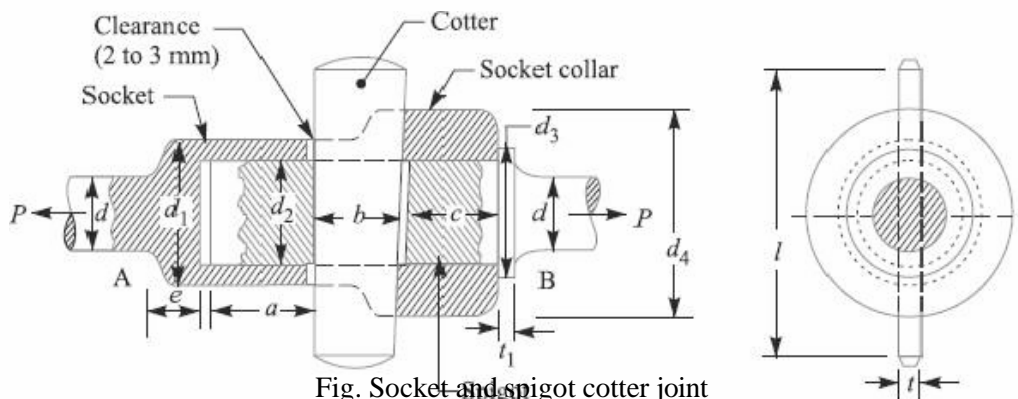

Fig. Socket and spigot cotter joint

### Design of Socket and Spigot Cotter Joint

The socket and spigot cotter joint is shown in Fig.

Let  $P$  = Load carried by the rods,

- d = Diameter of the rods,
- d<sub>1</sub> = Outside diameter of socket,
- d<sub>2</sub> = Diameter of spigot or inside diameter of socket,
- d<sub>3</sub> = Outside diameter of spigot collar,
- t<sub>1</sub> = Thickness of spigot collar,
- d<sub>4</sub> = Diameter of socket collar,
- c = Thickness of socket collar,
- b = Mean width of cotter,
- t = Thickness of cotter,
- l = Length of cotter,
- a = Distance from the end of the slot to the end of rod,
- σ<sub>t</sub> = Permissible tensile stress for the rods material,
- τ = Permissible shear stress for the cotter material, and
- σ<sub>c</sub> = Permissible crushing stress for the cotter material.

The dimensions for a socket and spigot cotter joint may be obtained by considering the various modes of failure as discussed below:

### 1. Failure of the rods in tension

$$P = \frac{\pi}{4} \times d^2 \times \sigma_t$$

From this equation, diameter of the rods (d) may be determined.

### 2. Failure of spigot in tension across the weakest section (or slot)

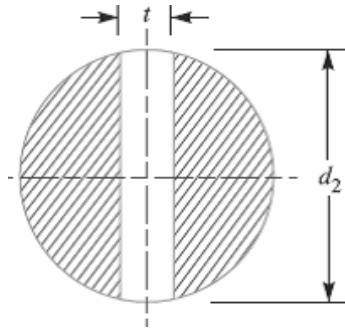

$$P = \left[ \frac{\pi}{4} (d_2)^2 - d_2 \times t \right] \sigma_t$$

From this equation, the diameter of spigot or inside diameter of socket (d<sub>2</sub>) may be determined. In actual practice, the thickness of cotter is usually taken as d<sub>2</sub> / 4.

### 3. Failure of the rod or cotter in crushing

$$P = d_2 \times t \times \sigma_c$$

From this equation, the induce crushing stress may be checked.

#### 4. Failure of the socket in tension across the slot

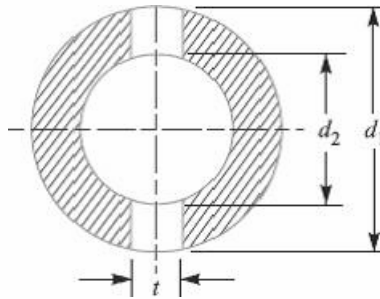

$$P = \left\{ \frac{\pi}{4} [(d_1)^2 - (d_2)^2] - (d_1 - d_2) t \right\} \sigma_t$$

From this equation, outside diameter of socket ( $d_1$ ) may be determined.

#### 5. Failure of cotter in shear

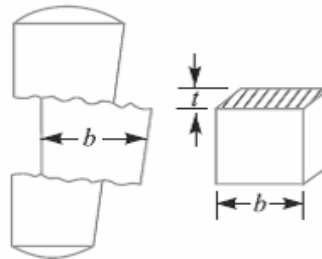

$$P = 2b \times t \times \tau$$

From this equation, width of cotter ( $b$ ) is determined.

#### 6. Failure of the socket collar in crushing

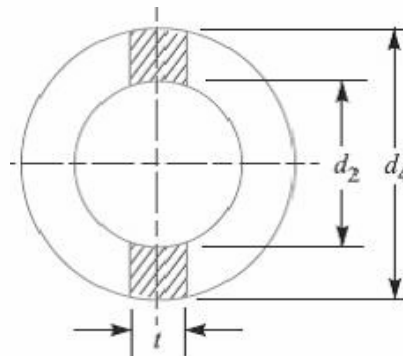

$$P = (d_4 - d_2) t \times \sigma_c$$

From this equation, the diameter of socket collar ( $d_4$ ) may be obtained.

#### 7. Failure of socket end in shearing

$$P = 2 (d_4 - d_2) c \times \tau$$

From this equation, the thickness of socket collar ( $c$ ) may be obtained.



### 8. Failure of rod end in shear

$$P = 2 a \times d_2 \times \tau$$

From this equation, the distance from the end of the slot to the end of the rod (a) may be obtained.

### 9. Failure of spigot collar in crushing

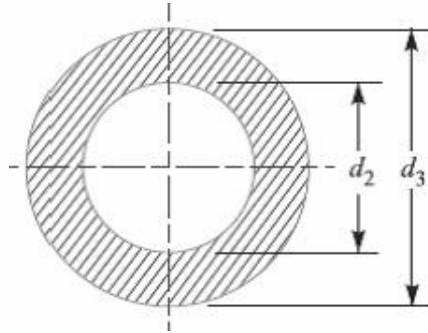

$$P = \frac{\pi}{4} [(d_3)^2 - (d_2)^2] \sigma_c$$

From this equation, the diameter of the spigot collar ( $d_3$ ) may be obtained.

### 10. Failure of the spigot collar in shearing

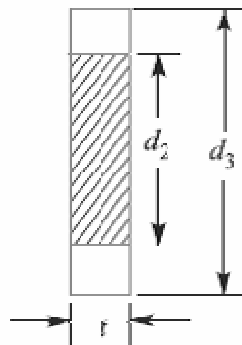

$$P = \pi d_2 \times t_1 \times \tau$$

From this equation, the thickness of spigot collar ( $t_1$ ) may be obtained.

### 11. Failure of cotter in bending

The maximum bending moment occurs at the centre of the cotter and is given by

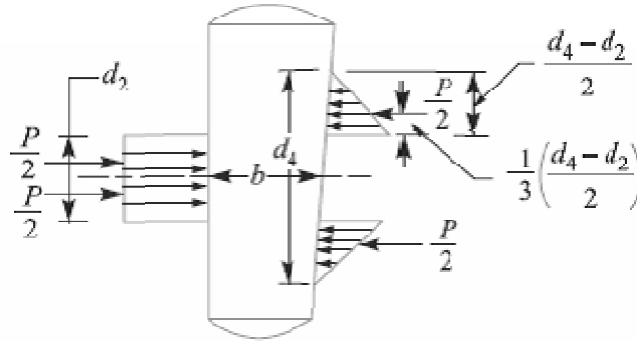

$$M_{max} = \frac{P}{2} \left( \frac{1}{3} \times \frac{d_4 - d_2}{2} + \frac{d_2}{2} \right) - \frac{P}{2} \times \frac{d_2}{4}$$

$$= \frac{P}{2} \left( \frac{d_4 - d_2}{6} + \frac{d_2}{2} - \frac{d_2}{4} \right) = \frac{P}{2} \left( \frac{d_4 - d_2}{6} + \frac{d_2}{4} \right)$$

We know that section modulus of the cotter,

$$Z = t \times b^2 / 6$$

Bending stress induced in the cotter,

$$\sigma_b = \frac{M_{max}}{Z} = \frac{\frac{P}{2} \left( \frac{d_4 - d_2}{6} + \frac{d_2}{4} \right)}{t \times b^2 / 6} = \frac{P (d_4 + 0.5 d_2)}{2 t \times b^2}$$

This bending stress induced in the cotter should be less than the allowable bending stress of the cotter.

**12.** The length of cotter (l) is taken as 4 d.

**13.** The taper in cotter should not exceed 1 in 24. In case the greater taper is required, then a locking device must be provided.

**14.** The draw of cotter is generally taken as 2 to 3 mm.

**Notes: 1.** when all the parts of the joint are made of steel, the following proportions in terms of diameter of the rod (d) are generally adopted:

$d_1 = 1.75 d$ ,  $d_2 = 1.21 d$ ,  $d_3 = 1.5 d$ ,  $d_4 = 2.4 d$ ,  $a = c = 0.75 d$ ,  $b = 1.3 d$ ,  $l = 4 d$ ,  $t = 0.31 d$ ,  $t_1 = 0.45 d$ ,  $e = 1.2 d$ .

Taper of cotter = 1 in 25, and draw of cotter = 2 to 3 mm.

**2.** If the rod and cotter are made of steel or wrought iron, then  $\tau = 0.8 \sigma_t$  and  $\sigma_c = 2 \sigma_t$  may be taken.

### **References:**

1. Machine Design - V. Bandari .
2. Machine Design – R.S. Khurmi
3. Design Data hand Book - S MD Jalaludin.

Problem:

Design and draw a cotter joint to support a load varying from 30 kN in compression to 30 kN in tension. The material used is carbon steel for which the following allowable stresses may be used. The load is applied statically. Tensile stress = compressive stress = 50 MPa ; shear stress = 35 MPa and crushing stress = 90 MPa.

**Solution.** Given :  $P = 30 \text{ kN} = 30 \times 10^3 \text{ N}$  ;  $\sigma_t = 50 \text{ MPa} = 50 \text{ N/mm}^2$  ;  $\tau = 35 \text{ MPa} = 35 \text{ N/mm}^2$  ;  $\sigma_c = 90 \text{ MPa} = 90 \text{ N/mm}^2$

### 1. Diameter of the rods

Let  $d$  = Diameter of the rods.

Considering the failure of the rod in tension. We know that load ( $P$ ),

$$30 \times 10^3 = \frac{\pi}{4} \times d^2 \times \sigma_t = \frac{\pi}{4} \times d^2 \times 50 = 39.3 d^2$$

$$\therefore d^2 = 30 \times 10^3 / 39.3 = 763 \quad \text{or} \quad d = 27.6 \text{ say } 28 \text{ mm Ans.}$$

### 2. Diameter of spigot and thickness of cotter

Let  $d_2$  = Diameter of spigot or inside diameter of socket, and

$t$  = Thickness of cotter. It may be taken as  $d_2/4$ .

Considering the failure of spigot in tension across the weakest section. We know that load ( $P$ ),

$$30 \times 10^3 = \left[ \frac{\pi}{4} (d_2)^2 - d_2 \times t \right] \sigma_t = \left[ \frac{\pi}{4} (d_2)^2 - d_2 \times \frac{d_2}{4} \right] 50 = 26.8 (d_2)^2$$

$$\therefore (d_2)^2 = 30 \times 10^3 / 26.8 = 1119.4 \quad \text{or} \quad d_2 = 33.4 \text{ say } 34 \text{ mm}$$

and thickness of cotter,  $t = \frac{d_2}{4} = \frac{34}{4} = 8.5 \text{ mm}$

Let us now check the induced crushing stress. We know that load ( $P$ ),

$$30 \times 10^3 = d_2 \times t \times \sigma_c = 34 \times 8.5 \times \sigma_c = 289 \sigma_c$$

$$\therefore \sigma_c = 30 \times 10^3 / 289 = 103.8 \text{ N/mm}^2$$

Since this value of  $\sigma_c$  is more than the given value of  $\sigma_c = 90 \text{ N/mm}^2$ , therefore the dimensions  $d_2 = 34 \text{ mm}$  and  $t = 8.5 \text{ mm}$  are not safe. Now let us find the values of  $d_2$  and  $t$  by substituting the value of  $\sigma_c = 90 \text{ N/mm}^2$  in the above expression, i.e.

$$30 \times 10^3 = d_2 \times \frac{d_2}{4} \times 90 = 22.5 (d_2)^2$$

$$\therefore (d_2)^2 = 30 \times 10^3 / 22.5 = 1333 \quad \text{or} \quad d_2 = 36.5 \text{ say } 40 \text{ mm Ans.}$$

and  $t = d_2/4 = 40/4 = 10 \text{ mm Ans.}$

### 3. Outside diameter of socket

Let  $d_1$  = Outside diameter of socket.

Considering the failure of the socket in tension across the slot. We know that load ( $P$ ),

$$\begin{aligned} 30 \times 10^3 &= \left[ \frac{\pi}{4} \{ (d_1)^2 - (d_2)^2 \} - (d_1 - d_2) t \right] \sigma_t \\ &= \left[ \frac{\pi}{4} \{ (d_1)^2 - (40)^2 \} - (d_1 - 40) 10 \right] 50 \end{aligned}$$

$$30 \times 10^3 / 50 = 0.7854 (d_1)^2 - 1256.6 - 10 d_1 + 400$$

or  $(d_1)^2 - 12.7d_1 - 1854.6 = 0$

$$\therefore d_1 = \frac{12.7 \pm \sqrt{(12.7)^2 + 4 \times 1854.6}}{2} = \frac{12.7 \pm 87.1}{2}$$

$= 49.9$  say 50 mm Ans. ...(Taking +ve sign)

**4. Width of cotter**

Let  $b$  = Width of cotter.

Considering the failure of the cotter in shear. Since the cotter is in double shear, therefore load ( $P$ ),

$$30 \times 10^3 = 2b \times t \times \tau = 2b \times 10 \times 35 = 700b$$

$$\therefore b = 30 \times 10^3 / 700 = 43 \text{ mm Ans.}$$

**5. Diameter of socket collar**

Let  $d_4$  = Diameter of socket collar.

Considering the failure of the socket collar and cotter in crushing. We know that load ( $P$ ),

$$30 \times 10^3 = (d_4 - d_2) t \times \sigma_c = (d_4 - 40) 10 \times 90 = (d_4 - 40) 900$$

$$\therefore d_4 - 40 = 30 \times 10^3 / 900 = 33.3 \text{ or } d_4 = 33.3 + 40 = 73.3 \text{ say } 75 \text{ mm Ans.}$$

**6. Thickness of socket collar**

Let  $c$  = Thickness of socket collar.

Considering the failure of the socket end in shearing. Since the socket end is in double shear, therefore load ( $P$ ),

$$30 \times 10^3 = 2(d_4 - d_2) c \times \tau = 2(75 - 40) c \times 35 = 2450c$$

$$\therefore c = 30 \times 10^3 / 2450 = 12 \text{ mm Ans.}$$

**7. Distance from the end of the slot to the end of the rod**

Let  $a$  = Distance from the end of slot to the end of the rod.

Considering the failure of the rod end in shear. Since the rod end is in double shear, therefore load ( $P$ ),

$$30 \times 10^3 = 2a \times d_2 \times \tau = 2a \times 40 \times 35 = 2800a$$

$$\therefore a = 30 \times 10^3 / 2800 = 10.7 \text{ say } 11 \text{ mm Ans.}$$

**8. Diameter of spigot collar**

Let  $d_3$  = Diameter of spigot collar.

Considering the failure of spigot collar in crushing. We know that load ( $P$ ),

$$30 \times 10^3 = \frac{\pi}{4} [(d_3)^2 - (d_2)^2] \sigma_c = \frac{\pi}{4} [(d_3)^2 - (40)^2] 90$$

or  $(d_3)^2 - (40)^2 = \frac{30 \times 10^3 \times 4}{90 \times \pi} = 424$

$$\therefore (d_3)^2 = 424 + (40)^2 = 2024 \text{ or } d_3 = 45 \text{ mm Ans.}$$

9. *Thickness of spigot collar*

Let  $t_1$  = Thickness of spigot collar.

Considering the failure of spigot collar in shearing. We know that load ( $P$ ),

$$30 \times 10^3 = \pi d_2 \times t_1 \times \tau = \pi \times 40 \times t_1 \times 35 = 4400 t_1$$

$$\therefore t_1 = 30 \times 10^3 / 4400 = 6.8 \text{ say } 8 \text{ mm Ans.}$$

10. The length of cotter ( $l$ ) is taken as  $4d$ .

$$\therefore l = 4d = 4 \times 28 = 112 \text{ mm Ans.}$$

11. The dimension  $e$  is taken as  $1.2d$ .

$$\therefore e = 1.2 \times 28 = 33.6 \text{ say } 34 \text{ mm Ans.}$$

**References:**

1. Machine Design - V. Bandari .
2. Machine Design – R.S. Khurmi
3. Design Data hand Book - S MD Jalaludin.

### Sleeve and Cotter Joint

Sometimes, a sleeve and cotter joint as shown in Fig., is used to connect two round rods or bars. In this type of joint, a sleeve or muff is used over the two rods and then two cotters (one on each rod end) are inserted in the holes provided for them in the sleeve and rods. The taper of cotter is usually 1 in 24. It may be noted that the taper sides of the two cotters should face each other as shown in Fig. The clearance is so adjusted that when the cotters are driven in, the two rods come closer to each other thus making the joint tight.

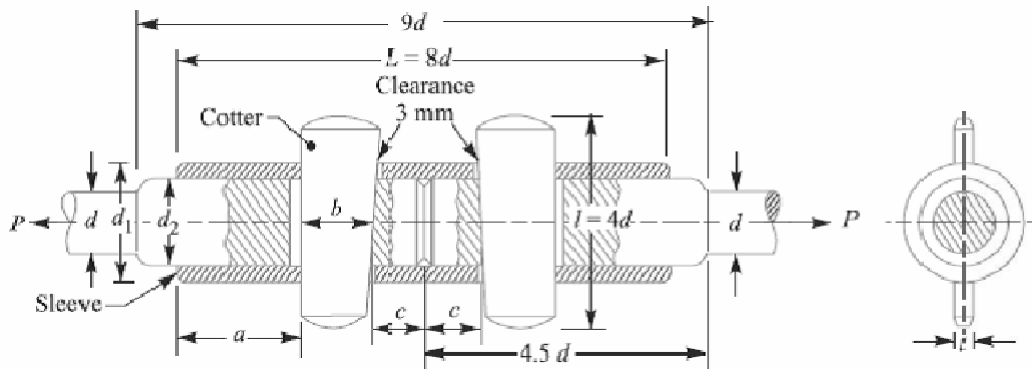

The various proportions for the sleeve and cotter joint in terms of the diameter of rod ( $d$ ) are as follows :

Outside diameter of sleeve,

$$d_1 = 2.5 d$$

Diameter of enlarged end of rod,

$$d_2 = \text{Inside diameter of sleeve} = 1.25 d$$

Length of sleeve,  $L = 8 d$

Thickness of cotter,  $t = d/4$  or  $0.31 d$

Width of cotter,  $b = 1.25 d$

Length of cotter,  $l = 4 d$

Distance of the rod end ( $a$ ) from the beginning to the cotter hole (inside the sleeve end) =

Distance of the rod end ( $c$ ) from its end to the cotter hole =  $1.25 d$

### Design of Sleeve and Cotter Joint

The sleeve and cotter joint is shown in Fig.

Let  $P$  = Load carried by the rods,

$d$  = Diameter of the rods,

$d_1$  = Outside diameter of sleeve,

$d_2$  = Diameter of the enlarged end of rod,

t = Thickness of cotter,

l = Length of cotter,

b = Width of cotter,

a = Distance of the rod end from the beginning to the cotter hole (inside the sleeve end),

c = Distance of the rod end from its end to the cotter hole,

$\sigma_t$ ,  $\tau$  and  $\sigma_c$  = Permissible tensile, shear and crushing stresses respectively for the material of the rods and cotter.

The dimensions for a sleeve and cotter joint may be obtained by considering the various modes of failure as discussed below:

### 1. Failure of the rods in tension

The rods may fail in tension due to the tensile load P. We know that

$$P = \frac{\pi}{4} \times d^2 \times \sigma_t$$

From this equation, diameter of the rods (d) may be obtained.

### 2. Failure of the rod in tension across the weakest section (i.e. slot)

$$P = \left[ \frac{\pi}{4} (d_2)^2 - d_2 \times t \right] \sigma_t$$

From this equation, the diameter of enlarged end of the rod ( $d_2$ ) may be obtained. The thickness of cotter is usually taken as  $d_2 / 4$ .

### 3. Failure of the rod or cotter in crushing

$$P = d_2 \times t \times \sigma_c$$

From this equation, the induced crushing stress may be checked.

### 4. Failure of sleeve in tension across the slot

$$P = \left[ \frac{\pi}{4} [(d_1)^2 - (d_2)^2] - (d_1 - d_2) t \right] \sigma_t$$

From this equation, the outside diameter of sleeve ( $d_1$ ) may be obtained.

### 5. Failure of cotter in shear

$$P = 2b \times t \times \tau$$

From this equation, width of cotter (b) may be determined.

### 6. Failure of rod end in shear

$$P = 2a \times d_2 \times \tau$$

From this equation, distance (a) may be determined.

### 7. Failure of sleeve end in shear

$$P = 2 (d_1 - d_2) c \times \tau$$

From this equation, distance (c) may be determined.

### **References:**

1. Machine Design - V.Bandari .
2. Machine Design – R.S. Khurmi
3. Design Data hand Book - S MD Jalaludin.



Problem:

Design a sleeve and cotter joint to resist a tensile load of 60 kN. All parts of the joint are made of the same material with the following allowable stresses:  $\sigma_t = 60 \text{ MPa}$  ;  $\tau = 70 \text{ MPa}$  ; and  $\sigma_c = 125 \text{ MPa}$ .

Solution. Given :  $P = 60 \text{ kN} = 60 \times 10^3 \text{ N}$  ;  $\sigma_t = 60 \text{ MPa} = 60 \text{ N/mm}^2$  ;  $\tau = 70 \text{ MPa} = 70 \text{ N/mm}^2$  ;  
 $\sigma_c = 125 \text{ MPa} = 125 \text{ N/mm}^2$

### 1. Diameter of the rods

Let  $d =$  Diameter of the rods.

Considering the failure of the rods in tension. We know that load ( $P$ ),

$$60 \times 10^3 = \frac{\pi}{4} \times d^2 \times \sigma_t = \frac{\pi}{4} \times d^2 \times 60 = 47.13 d^2$$

$$\therefore d^2 = 60 \times 10^3 / 47.13 = 1273 \text{ or } d = 35.7 \text{ say } 36 \text{ mm Ans.}$$

### 2. Diameter of enlarged end of rod and thickness of cotter

Let  $d_2 =$  Diameter of enlarged end of rod, and

$t =$  Thickness of cotter. It may be taken as  $d_2 / 4$ .

Considering the failure of the rod in tension across the weakest section (*i.e.* slot). We know that load ( $P$ ),

$$60 \times 10^3 = \left[ \frac{\pi}{4} (d_2)^2 - d_2 \times t \right] \sigma_t = \left[ \frac{\pi}{4} (d_2)^2 - d_2 \times \frac{d_2}{4} \right] 60 = 32.13 (d_2)^2$$

$$\therefore (d_2)^2 = 60 \times 10^3 / 32.13 = 1867 \text{ or } d_2 = 43.2 \text{ say } 44 \text{ mm Ans.}$$

and thickness of cotter,

$$t = \frac{d_2}{4} = \frac{44}{4} = 11 \text{ mm Ans.}$$

Let us now check the induced crushing stress in the rod or cotter. We know that load ( $P$ ),

$$60 \times 10^3 = d_2 \times t \times \sigma_c = 44 \times 11 \times \sigma_c = 484 \sigma_c$$

$$\therefore \sigma_c = 60 \times 10^3 / 484 = 124 \text{ N/mm}^2$$

Since the induced crushing stress is less than the given value of  $125 \text{ N/mm}^2$ , therefore the dimensions  $d_2$  and  $t$  are within safe limits.

### 3. Outside diameter of sleeve

Let  $d_1 =$  Outside diameter of sleeve.

Considering the failure of sleeve in tension across the slot. We know that load ( $P$ )

$$\begin{aligned} 60 \times 10^3 &= \left[ \frac{\pi}{4} [(d_1)^2 - (d_2)^2] - (d_1 - d_2) t \right] \sigma_t \\ &= \left[ \frac{\pi}{4} [(d_1)^2 - (44)^2] - (d_1 - 44) 11 \right] 60 \end{aligned}$$

$$\begin{aligned} \therefore 60 \times 10^3 / 60 &= 0.7854 (d_1)^2 - 1520.7 - 11 d_1 + 484 \\ \text{or } (d_1)^2 - 14 d_1 - 2593 &= 0 \\ \therefore d_1 &= \frac{14 \pm \sqrt{(14)^2 + 4 \times 2593}}{2} = \frac{14 \pm 102.8}{2} \\ &= 58.4 \text{ say } 60 \text{ mm Ans.} \end{aligned}$$

4. *Width of cotter*

Let  $b$  = Width of cotter.

Considering the failure of cotter in shear. Since the cotter is in double shear, therefore load ( $P$ ),

$$60 \times 10^3 = 2 b \times t \times \tau = 2 \times b \times 11 \times 70 = 1540 b$$

$$\therefore b = 60 \times 10^3 / 1540 = 38.96 \text{ say } 40 \text{ mm Ans.}$$

5. *Distance of the rod from the beginning to the cotter hole (inside the sleeve end)*

Let  $a$  = Required distance.

Considering the failure of the rod end in shear. Since the rod end is in double shear, therefore load ( $P$ ),

$$60 \times 10^3 = 2 a \times d_2 \times \tau = 2 a \times 44 \times 70 = 6160 a$$

$$\therefore a = 60 \times 10^3 / 6160 = 9.74 \text{ say } 10 \text{ mm Ans.}$$

6. *Distance of the rod end from its end to the cotter hole*

Let  $c$  = Required distance.

Considering the failure of the sleeve end in shear. Since the sleeve end is in double shear, therefore load ( $P$ ),

$$60 \times 10^3 = 2 (d_1 - d_2) c \times \tau = 2 (60 - 44) c \times 70 = 2240 c$$

$$\therefore c = 60 \times 10^3 / 2240 = 26.78 \text{ say } 28 \text{ mm Ans.}$$

**References:**

1. Machine Design - V. Bandari .
2. Machine Design – R.S. Khurmi
3. Design Data hand Book - S MD Jalaludin.

### Gib and Cotter Joint

This joint is generally used to connect two rods of square or rectangular section. To make the joint; one end of the rod is formed into a U-fork, into which, the end of the other rod fits-in. When a cotter is driven-in, the friction between the cotter and straps of the U-fork, causes the straps open. This is prevented by the use of a gib.

A gib is also a wedge-shaped piece of rectangular cross-section with two rectangular projections, called lugs. One side of the gib is tapered and the other straight. The tapered side of the gib bears against the tapered side of the cotter such that the outer edges of the cotter and gib as a unit are parallel. This facilitates making of slots with parallel edges, unlike the tapered edges in case of ordinary cotter joint. The gib also provides larger surface for the cotter to slide on. For making the joint, the gib is placed in position first, and then the cotter is driven-in.

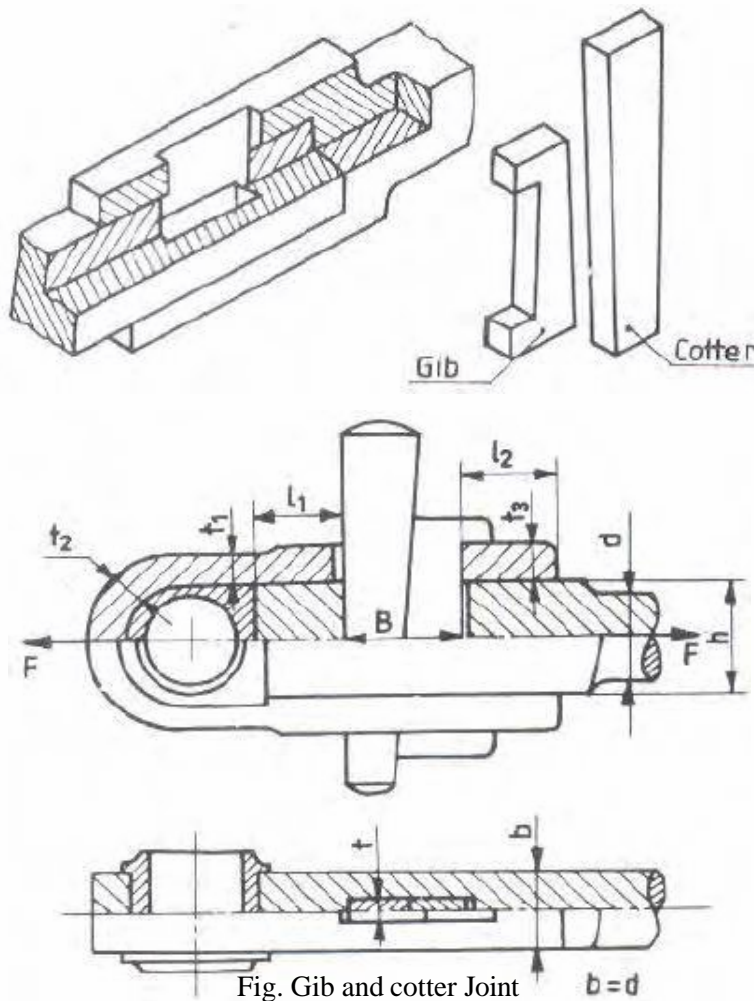

Fig. Gib and cotter Joint

Let  $F$  be the maximum tensile or compressive force in the connecting rod, and

$b$  = width of the strap, which may be taken as equal to the diameter of the rod.  $d$

$h$  = height of the rod end

$t_1$  = thickness of the strap at the thinnest part

$t_2$  = thickness of the strap at the curved portion

$t_3$  = thickness of the strap across the slot

$l_1$  = length of the rod end, beyond the slot

$l_2$  = length of the strap, beyond the slot

$B$  = width of the cotter and gib

$t$  = thickness of the cotter

Let the rod, strap, cotter, and gib are made of the same material with  $\sigma_c$ ,  $\sigma_t$  and  $\tau$  as the permissible stresses. The following are the possible modes of failure, and the corresponding design equations, which may be considered for the design of the joint:

1. Tension failure of the rod across the section of diameter,  $d$

$$F = \frac{\pi d^2}{4} \times \sigma_t$$

2. Tension failure of the rod across the slot (Fig.1)

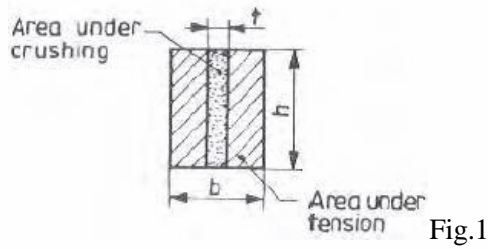

$$F = (bh - ht) \sigma_t$$

If the rod and strap are made of the same material, and for equality of strength,  $h=2t_3$

3. Tension failure of the strap, across the thinnest part (Fig.2)

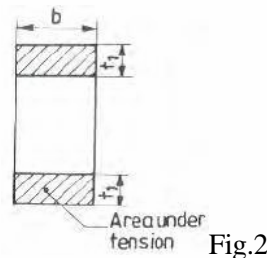

$$F = 2b t_1 \sigma_t$$

4. Tension failure of the strap across the slot (Fig.3)

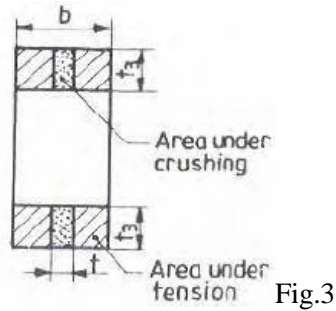

$$F = 2 b t_3 - 2 t t_3 = 2 t_3 (b - t) \sigma_t$$

The thickness,  $t_2$  may be taken as  $(1.15 \text{ to } 1.5) t$ , and

Thickness of the cotter,  $t = b/4$ .

5. Crushing between the rod and cotter (Fig.1)

$$F = h t \sigma_c ; \text{ and } h = 2 t_3$$

6. Crushing between the strap and gib (Fig.3)

$$F = 2 t t_3 \sigma_c$$

7. Shear failure of the rod end. It is under double shear (Fig.4).

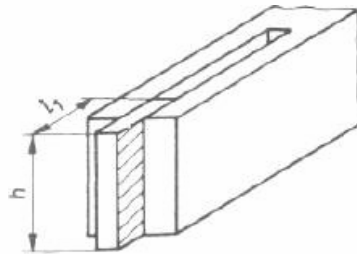

Fig.4

$$F = 2 l_1 h t$$

8. Shear failure of the strap end. It is under double shear (Fig.5).

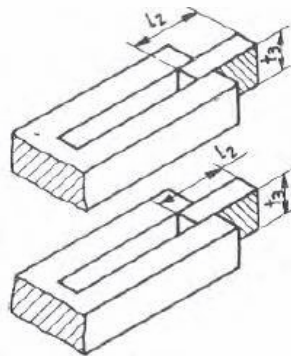

Fig.5

$$F = 4 l_2 t_3 t$$

9. Shear failure of the cotter and gib. It is under double shear.

$$F = 2 B t \tau$$

The following proportions for the widths of the cotter and gib may be followed:

Width of the cotter = 0.45 B

Width of the gib = 0.55 B

The above equations may be solved, keeping in mind about the various relations and proportions suggested.

### **Problem:**

Design a cotter joint to connect piston rod to the crosshead of a double acting steam engine. The diameter of the cylinder is 300 mm and the steam pressure is 1 N/mm<sup>2</sup>. The allowable stresses for the material of cotter and piston rod are as follows:  $\sigma_t = 50$  MPa ;  $\tau = 40$  MPa ; and  $\sigma_c = 84$  MPa.

**Solution.** Given :  $D = 300$  mm ;  $p = 1$  N/mm<sup>2</sup> ;  $\sigma_t = 50$  MPa = 50 N/mm<sup>2</sup> ;  $\tau = 40$  MPa = 40 N/mm<sup>2</sup> ;  $\sigma_c = 84$  MPa = 84 N/mm<sup>2</sup>

We know that maximum load on the piston rod,

$$P = \frac{\pi}{4} \times D^2 \times p = \frac{\pi}{4} (300)^2 \times 1 = 70\,695 \text{ N}$$

The various dimensions for the cotter joint are obtained by considering the different modes of failure as discussed below :

#### 1. Diameter of piston rod at cotter

Let  $d_2$  = Diameter of piston rod at cotter, and  
 $t$  = Thickness of cotter. It may be taken as  $0.3 d_2$ .

Considering the failure of piston rod in tension at cotter. We know that load ( $P$ ),

$$70\,695 = \left[ \frac{\pi}{4} (d_2)^2 - d_2 \times t \right] \sigma_t = \left[ \frac{\pi}{4} (d_2)^2 - 0.3 (d_2)^2 \right] 50 = 24.27 (d_2)^2$$

$$\therefore (d_2)^2 = 70\,695 / 24.27 = 2913 \quad \text{or} \quad d_2 = 53.97 \text{ say } 55 \text{ mm Ans.}$$

and  $t = 0.3 d_2 = 0.3 \times 55 = 16.5 \text{ mm Ans.}$

#### 2. Width of cotter

Let  $b$  = Width of cotter.

Considering the failure of cotter in shear. Since the cotter is in double shear, therefore load ( $P$ ),

$$70\,695 = 2 b \times t \times \tau = 2 b \times 16.5 \times 40 = 1320 b$$

$$\therefore b = 70\,695 / 1320 = 53.5 \text{ say } 54 \text{ mm Ans.}$$

#### 3. Diameter of socket

Let  $d_3$  = Diameter of socket.

Considering the failure of socket in tension at cotter. We know that load ( $P$ ),

$$\begin{aligned} 70\,695 &= \left\{ \frac{\pi}{4} [(d_3)^2 - (d_2)^2] - (d_3 - d_2) t \right\} \sigma_t \\ &= \left\{ \frac{\pi}{4} [(d_3)^2 - (55)^2] - (d_3 - 55) 16.5 \right\} 50 \\ &= 39.27 (d_3)^2 - 118\,792 - 825 d_3 + 45\,375 \end{aligned}$$

or  $(d_2)^2 - 21 d_3 - 3670 = 0$

$$\therefore d_3 = \frac{21 + \sqrt{(21)^2 + 4 \times 3670}}{2} = \frac{21 + 123}{2} = 72 \text{ mm} \dots (\text{Taking +ve sign})$$

Let us now check the induced crushing stress in the socket. We know that load ( $P$ ),

$$70\ 695 = (d_3 - d_2) l \times \sigma_c = (72 - 55) 16.5 \times \sigma_c = 280.5 \sigma_c$$

$$\therefore \sigma_c = 70\ 695 / 280.5 = 252 \text{ N/mm}^2$$

Since the induced crushing is greater than the permissible value of  $84 \text{ N/mm}^2$ , therefore let us

find the value of  $d_3$  by substituting  $\sigma_c = 84 \text{ N/mm}^2$  in the above expression, *i.e.*

$$70\ 695 = (d_3 - 55) 16.5 \times 84 = (d_3 - 55) 1386$$

$$\therefore d_3 - 55 = 70\ 695 / 1386 = 51$$

or  $d_3 = 55 + 51 = 106 \text{ mm Ans.}$

We know the tapered length of the piston rod,

$$L = 2.2 d_2 = 2.2 \times 55 = 121 \text{ mm Ans.}$$

Assuming the taper of the piston rod as 1 in 20, therefore the diameter of the parallel part of the piston rod,

$$d = d_2 + \frac{L}{2} \times \frac{1}{20} = 55 + \frac{121}{2} \times \frac{1}{20} = 58 \text{ mm Ans.}$$

and diameter of the piston rod at the tapered end,

$$d_1 = d_2 - \frac{L}{2} \times \frac{1}{20} = 55 - \frac{121}{2} \times \frac{1}{20} = 52 \text{ mm Ans.}$$

### References:

1. Machine Design - V. Bandari .
2. Machine Design – R.S. Khurmi
3. Design Data hand Book - S MD Jalaludin.

## **DESIGN OF KNUCKLE JOINT**

The following figure shows a knuckle joint with the size parameters and proportions indicated. In general, the rods connected by this joint are subjected to tensile loads, although if the rods are guided, they may support compressive loads as well.

Let  $F$  = tensile load to be resisted by the joint

$d$  = diameter of the rods

$d_1$  = diameter of the knuckle pin

$D$  = outside diameter of the eye

$A$  = thickness of the fork

$B$  = thickness of the eye

Obviously, if the rods are made of the same material, the parameters,  $A$  and  $B$  are related as,

$$B=2A$$

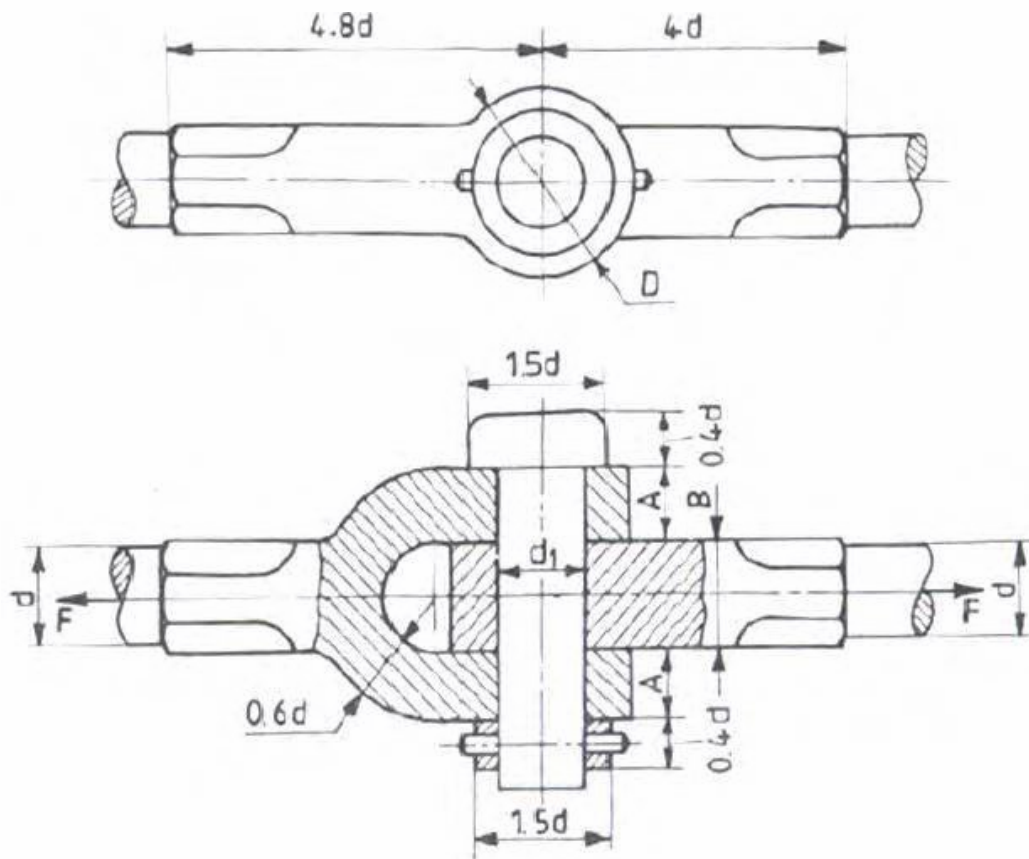

Fig. Knuckle Joint

Let the rods and pin are made of the same material, with  $\sigma_t$ ,  $\sigma_c$  and  $\tau$  as the permissible stresses. The following are the possible modes of failure, and the corresponding design equations, which may be considered for the design of the joint:

1. Tension failure of the rod, across the section of diameter,  $d$



$$F = \frac{\square d^2}{4}$$

2. Tension failure of the eye (fig.1)

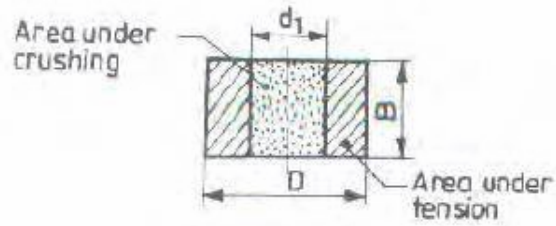

Fig.1

$$F = (D - d_1) B \sigma_t$$

3. Tension failure of the fork (fig.2)

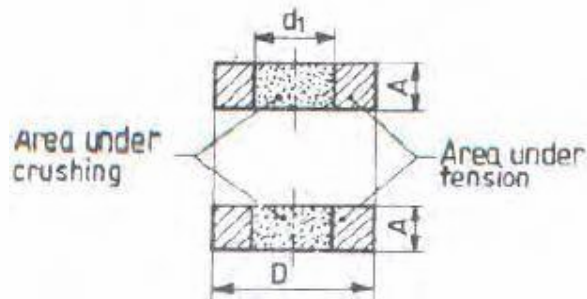

Fig.2

$$F = 2 (D - d_1) A \sigma_t$$

4. Shear failure of the eye (Fig.3)

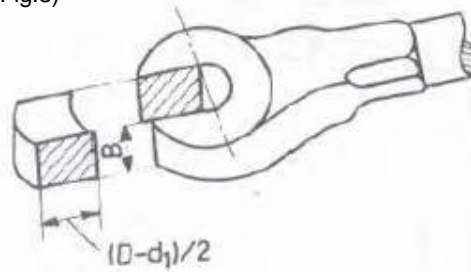

Fig.3

$$F = (D - d_1) B \tau$$

5. Shear failure of the fork (Fig.4)

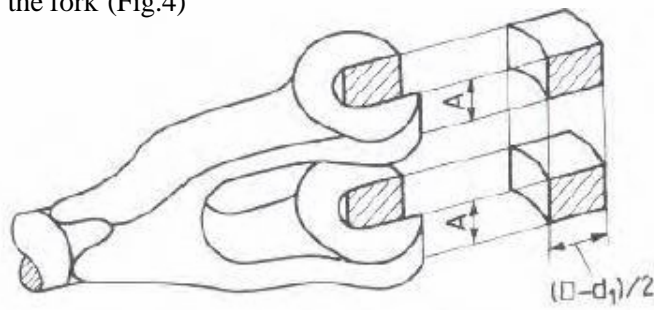

Fig.4

$$F = 2 (D - d_1) A \tau$$

6. Shear failure of the pin. It is under double shear.

$$F = 2x \frac{\pi}{4} d^2 \sigma_s$$

7. Crushing between the pin and eye (fig.1)

$$F = d_1 B \sigma_c$$

8. Crushing between the pin and fork (fig.2)

$$F = 2 d_1 A \sigma_c$$

For size parameters, not covered by the above design equations; proportions as indicated in the figure may be followed.

Problem:

Design a knuckle joint to transmit 150 kN. The design stresses may be taken as 75 MPa in tension, 60 MPa in shear and 150 MPa in compression.

Solution. Given :  $P = 150 \text{ kN} = 150 \times 10^3 \text{ N}$  ;  $\sigma_t = 75 \text{ MPa} = 75 \text{ N/mm}^2$  ;  $\tau = 60 \text{ MPa} = 60 \text{ N/mm}^2$  ;  
 $\sigma_c = 150 \text{ MPa} = 150 \text{ N/mm}^2$

### 1. Failure of the solid rod in tension

Let  $d =$  Diameter of the rod.

We know that the load transmitted ( $P$ ),

$$150 \times 10^3 = \frac{\pi}{4} \times d^2 \times \sigma_t = \frac{\pi}{4} \times d^2 \times 75 = 59 d^2$$

$$\therefore d^2 = 150 \times 10^3 / 59 = 2540 \quad \text{or} \quad d = 50.4 \text{ say } 52 \text{ mm Ans.}$$

Now the various dimensions are fixed as follows :

Diameter of knuckle pin,

$$d_1 = d = 52 \text{ mm}$$

Outer diameter of eye,  $d_2 = 2d = 2 \times 52 = 104 \text{ mm}$

Diameter of knuckle pin head and collar,

$$d_3 = 1.5d = 1.5 \times 52 = 78 \text{ mm}$$

Thickness of single eye or rod end,

$$t = 1.25d = 1.25 \times 52 = 65 \text{ mm}$$

Thickness of fork,  $t_1 = 0.75d = 0.75 \times 52 = 39 \text{ say } 40 \text{ mm}$

Thickness of pin head,  $t_2 = 0.5d = 0.5 \times 52 = 26 \text{ mm}$

### 2. Failure of the knuckle pin in shear

Since the knuckle pin is in double shear, therefore load ( $P$ ),

$$150 \times 10^3 = 2 \times \frac{\pi}{4} \times (d_1)^2 \tau = 2 \times \frac{\pi}{4} \times (52)^2 \tau = 4248 \tau$$

$$\therefore \tau = 150 \times 10^3 / 4248 = 35.3 \text{ N/mm}^2 = 35.3 \text{ MPa}$$

### 3. Failure of the single eye or rod end in tension

The single eye or rod end may fail in tension due to the load. We know that load ( $P$ ),

$$150 \times 10^3 = (d_2 - d_1) t \times \sigma_t = (104 - 52) 65 \times \sigma_t = 3380 \sigma_t$$

$$\therefore \sigma_t = 150 \times 10^3 / 3380 = 44.4 \text{ N/mm}^2 = 44.4 \text{ MPa}$$

### 4. Failure of the single eye or rod end in shearing

The single eye or rod end may fail in shearing due to the load. We know that load ( $P$ ),

$$150 \times 10^3 = (d_2 - d_1) t \times \tau = (104 - 52) 65 \times \tau = 3380 \tau$$

$$\therefore \tau = 150 \times 10^3 / 3380 = 44.4 \text{ N/mm}^2 = 44.4 \text{ MPa}$$

### 5. Failure of the single eye or rod end in crushing

The single eye or rod end may fail in crushing due to the load. We know that load ( $P$ ),

$$150 \times 10^3 = d_1 \times t \times \sigma_c = 52 \times 65 \times \sigma_c = 3380 \sigma_c$$

$$\therefore \sigma_c = 150 \times 10^3 / 3380 = 44.4 \text{ N/mm}^2 = 44.4 \text{ MPa}$$

### 6. Failure of the forked end in tension

The forked end may fail in tension due to the load. We know that load ( $P$ ),

$$150 \times 10^3 = (d_2 - d_1) 2 t_1 \times \sigma_t = (104 - 52) 2 \times 40 \times \sigma_t = 4160 \sigma_t$$

$$\therefore \sigma_t = 150 \times 10^3 / 4160 = 36 \text{ N/mm}^2 = 36 \text{ MPa}$$

### 7. Failure of the forked end in shear

The forked end may fail in shearing due to the load. We know that load ( $P$ ),

$$150 \times 10^3 = (d_2 - d_1) 2 t_1 \times \tau = (104 - 52) 2 \times 40 \times \tau = 4160 \tau$$

$$\therefore \tau = 150 \times 10^3 / 4160 = 36 \text{ N/mm}^2 = 36 \text{ MPa}$$

### 8. Failure of the forked end in crushing

The forked end may fail in crushing due to the load. We know that load ( $P$ ),

$$150 \times 10^3 = d_1 \times 2 t_1 \times \sigma_c = 52 \times 2 \times 40 \times \sigma_c = 4160 \sigma_c$$

$$\therefore \sigma_c = 150 \times 10^3 / 4160 = 36 \text{ N/mm}^2 = 36 \text{ MPa}$$

From above, we see that the induced stresses are less than the given design stresses, therefore the joint is safe.

### **References:**

1. Machine Design - V. Bandari .
2. Machine Design – R.S. Khurmi
3. Design Data hand Book - S MD Jalaludin.

## **Shafts:**

A shaft is a rotating machine element which is used to transmit power from one place to another. The power is delivered to the shaft by some tangential force and the resultant torque (or twisting moment) set up within the shaft permits the power to be transferred to various machines linked up to the shaft. In order to transfer the power from one shaft to another, the various members such as pulleys, gears etc., are mounted on it. These members along with the forces exerted upon them causes the shaft to bending.

In other words, we may say that a shaft is used for the transmission of torque and bending moment. The various members are mounted on the shaft by means of keys or splines. The shafts are usually cylindrical, but may be square or cross-shaped in section. They are solid in cross-section but sometimes hollow shafts are also used. An *axle*, though similar in shape to the shaft, is a stationary machine element and is used for the transmission of bending moment only. It simply acts as a support for some rotating body such as hoisting drum, a car wheel or a rope sheave. A *spindle* is a short shaft that imparts motion either to a cutting tool (*e.g.* drill press spindles) or to a work piece (*e.g.* lathe spindles).

### **Types of Shafts**

The following two types of shafts are important from the subject point of view:

- 1. *Transmission shafts.*** These shafts transmit power between the source and the machines absorbing power. The counter shafts, line shafts, over head shafts and all factory shafts are transmission shafts. Since these shafts carry machine parts such as pulleys, gears etc., therefore they are subjected to bending in addition to twisting.
- 2. *Machine shafts.*** These shafts form an integral part of the machine itself. The crank shaft is an example of machine shaft.

### **Stresses in Shafts**

The following stresses are induced in the shafts:

- 1.** Shear stresses due to the transmission of torque (*i.e.* due to torsional load).
- 2.** Bending stresses (tensile or compressive) due to the forces acting upon machine elements like gears, pulleys etc. as well as due to the weight of the shaft itself.
- 3.** Stresses due to combined torsional and bending loads.

### **Design of Shafts**

The shafts may be designed on the basis of

- 1.** Strength, and **2.** Rigidity and stiffness.

In designing shafts on the basis of strength, the following cases may be considered:

- (a) Shafts subjected to twisting moment or torque only,
- (b) Shafts subjected to bending moment only,
- (c) Shafts subjected to combined twisting and bending moments, and
- (d) Shafts subjected to axial loads in addition to combined torsional and bending loads.

### **Shafts Subjected to Twisting Moment Only**

#### **a) Solid shaft:**

When the shaft is subjected to a twisting moment (or torque) only, then the diameter of the shaft may be obtained by using the torsion equation. We know that

$$\frac{T}{J} = \frac{\tau}{r}$$

Where  $T$  = Twisting moment (or torque) acting upon the shaft,

$J$  = Polar moment of inertia of the shaft about the axis of rotation,

$\tau$  = Torsional shear stress, and

$r$  = Distance from neutral axis to the outer most fibre

=  $d / 2$ ; where  $d$  is the diameter of the shaft.

We know that for round solid shaft, polar moment of inertia,

$$J = \frac{\pi}{32} d^4$$

Then we get, 
$$T = \frac{\pi}{16} \tau d^3$$

From this equation, diameter of the solid shaft ( $d$ ) may be obtained.

#### **b) Hollow Shaft:**

We also know that for hollow shaft, polar moment of inertia,

$$J = \frac{\pi}{32} [(d_o)^4 - (d_i)^4]$$

Where  $d_o$  and  $d_i$  = Outside and inside diameter of the shaft, and  $r = d_o / 2$ .

Substituting these values in equation (i), we have

$$\frac{T}{\frac{\pi}{32} [(d_o)^4 - (d_i)^4]} = \frac{\tau}{\frac{d_o}{2}} \quad \text{or} \quad T = \frac{\pi}{16} \times \tau \left[ \frac{(d_o)^4 - (d_i)^4}{d_o} \right]$$

Let  $k$  = Ratio of inside diameter and outside diameter of the shaft =  $d_i / d_o$

Now the equation (iii) may be written as

$$T = \frac{\pi}{16} \times \tau \times \frac{(d_o)^4}{d_o} \left[ 1 - \left( \frac{d_i}{d_o} \right)^4 \right] = \frac{\pi}{16} \times \tau (d_o)^3 (1 - k^4)$$

From the equations, the outside and inside diameter of a hollow shaft may be determined. It may be noted that

1. The hollow shafts are usually used in marine work. These shafts are stronger per kg of material and they may be forged on a mandrel, thus making the material more homogeneous than would be possible for a solid shaft. When a hollow shaft is to be made equal in strength to a solid shaft, the twisting moment of both the shafts must be same. In other words, for the same material of both the shafts,

$$T = \frac{\pi}{16} \times \tau \left[ \frac{(d_o)^4 - (d_i)^4}{d_o} \right] = \frac{\pi}{16} \times \tau \times d^3$$

$$\therefore \frac{(d_o)^4 - (d_i)^4}{d_o} = d^3 \quad \text{or} \quad (d_o)^3 (1 - k^4) = d^3$$

2. The twisting moment ( $T$ ) may be obtained by using the following relation:

We know that the power transmitted (in watts) by the shaft,

$$P = \frac{2\pi N \times T}{60} \quad \text{or} \quad T = \frac{P \times 60}{2\pi N}$$

Where  $T$  = Twisting moment in N-m, and

$N$  = Speed of the shaft in r.p.m.

3. In case of belt drives, the twisting moment ( $T$ ) is given by

$$T = (T_1 - T_2) R$$

Where  $T_1$  and  $T_2$  = Tensions in the tight side and slack side of the belt respectively, and  $R$  = Radius of the pulley.

### **Shafts Subjected to Bending Moment Only**

#### **a) Solid Shaft:**

When the shaft is subjected to a bending moment only, then the maximum stress (tensile or compressive) is given by the bending equation. We know that

$$\frac{M}{I} = \frac{\sigma_b}{y}$$

Where  $M$  = Bending moment,

$I$  = Moment of inertia of cross-sectional area of the shaft about the axis of rotation,

$\sigma_b$  = Bending stress, and

$y$  = Distance from neutral axis to the outer-most fibre.

We know that for a round solid shaft, moment of inertia,

$$I = \frac{\pi}{64} \times d^4 \quad \text{and} \quad y = \frac{d}{2}$$

Substituting these values in equation

$$\frac{M}{\frac{\pi}{64} \times d^4} = \frac{\sigma_b}{\frac{d}{2}} \quad \text{or} \quad M = \frac{\pi}{32} \times \sigma_b \times d^3$$

From this equation, diameter of the solid shaft ( $d$ ) may be obtained.

### **b) Hollow Shaft:**

We also know that for a hollow shaft, moment of inertia,

$$I = \frac{\pi}{64} [(d_o)^4 - (d_i)^4] = \frac{\pi}{64} (d_o)^4 (1 - k^4) \quad \dots(\text{where } k = d_i / d_o)$$

And  $y = d_o / 2$

Again substituting these values in equation, we have

$$\frac{M}{\frac{\pi}{64} (d_o)^4 (1 - k^4)} = \frac{\sigma_b}{\frac{d_o}{2}} \quad \text{or} \quad M = \frac{\pi}{32} \times \sigma_b (d_o)^3 (1 - k^4)$$

From this equation, the outside diameter of the shaft ( $d_o$ ) may be obtained.

### **Shafts Subjected to Combined Twisting Moment and Bending Moment**

When the shaft is subjected to combined twisting moment and bending moment, then the shaft must be designed on the basis of the two moments simultaneously. Various theories have been suggested to account for the elastic failure of the materials when they are subjected to various types of combined stresses. The following two theories are important from the subject point of view:

1. Maximum shear stress theory or Guest's theory. It is used for ductile materials such as mild steel.
2. Maximum normal stress theory or Rankine's theory. It is used for brittle materials such as cast iron.

Let  $\tau$  = Shear stress induced due to twisting moment, and

$\sigma_b$  = Bending stress (tensile or compressive) induced due to bending moment.

### **a) Solid Shaft:**

According to maximum shear stress theory, the maximum shear stress in the shaft,

$$\tau_{max} = \frac{1}{2} \sqrt{(\sigma_b)^2 + 4\tau^2}$$

Substituting the values of  $\sigma_b$  and  $\tau$

$$\tau_{max} = \frac{1}{2} \sqrt{\left(\frac{32M}{\pi d^3}\right)^2 + 4\left(\frac{16T}{\pi d^3}\right)^2} = \frac{16}{\pi d^3} \left[\sqrt{M^2 + T^2}\right]$$

$$\text{or} \quad \frac{\pi}{16} \times \tau_{max} \times d^3 = \sqrt{M^2 + T^2}$$

The expression  $\sqrt{M^2 + T^2}$  is known as **equivalent twisting moment** and is denoted by  $T_e$ . The equivalent twisting moment may be defined as that twisting moment, which when acting alone, produces the same shear stress ( $\tau$ ) as the actual twisting moment. By limiting the maximum shear stress ( $\tau_{max}$ ) equal to the allowable shear stress ( $\tau$ ) for the material, the equation (i) may be written as

$$T_e = \sqrt{M^2 + T^2} = \frac{\pi}{16} \times \tau \times d^3$$

From this expression, diameter of the shaft (d) may be evaluated.

Now according to maximum normal stress theory, the maximum normal stress in the shaft,

$$\sigma_{b(max)} = \frac{1}{2} \sigma_b + \frac{1}{2} \sqrt{(\sigma_b)^2 + 4\tau^2}$$

$$= \frac{1}{2} \times \frac{32M}{\pi d^3} + \frac{1}{2} \sqrt{\left(\frac{32M}{\pi d^3}\right)^2 + 4\left(\frac{16T}{\pi d^3}\right)^2}$$

$$= \frac{32}{\pi d^3} \left[ \frac{1}{2} (M + \sqrt{M^2 + T^2}) \right]$$

$$\text{or} \quad \frac{\pi}{32} \times \sigma_{b(max)} \times d^3 = \frac{1}{2} [M + \sqrt{M^2 + T^2}]$$

The expression  $\frac{1}{2} [M + \sqrt{M^2 + T^2}]$  is known as **equivalent bending moment** and is denoted

by  $M_e$ . The equivalent bending moment may be defined as that moment which when acting alone produces the same tensile or compressive stress ( $\sigma_b$ ) as the actual bending moment. By limiting the maximum normal stress [ $\sigma_b$  (maximum)] to the allowable bending stress ( $\sigma_b$ ), then the equation (iv) may be written as

$$M_e = \frac{1}{2} [M + \sqrt{M^2 + T^2}] = \frac{\pi}{32} \times \sigma_b \times d^3$$

From this expression, diameter of the shaft (d) may be evaluated.

#### **b) Hollow shaft:**



In case of a hollow shaft, the equations (ii) and (v) may be written as

$$T_e = \sqrt{M^2 + T^2} = \frac{\pi}{16} \times \tau (d_o)^3 (1 - k^4)$$

$$M_e = \frac{1}{2} \left( M + \sqrt{M^2 + T^2} \right) = \frac{\pi}{32} \times \sigma_b (d_o)^3 (1 - k^4)$$

It is suggested that diameter of the shaft may be obtained by using both the theories and the larger of the two values is adopted.

**References:**

1. Machine Design - V.Bandari .
2. Machine Design – R.S. Khurmi
3. Design Data hand Book - S MD Jalaludin.

**Problem:**

A shaft is supported by two bearings placed 1 m apart. A 600 mm diameter pulley is mounted at a distance of 300 mm to the right of left hand bearing and this drives a pulley directly below it with the help of belt having maximum tension of 2.25 kN. Another pulley 400 mm diameter is placed 200 mm to the left of right hand bearing and is driven with the help of electric motor and belt, which is placed horizontally to the right. The angle of contact for both the pulleys is  $180^\circ$  and  $\mu = 0.24$ . Determine the suitable diameter for a solid shaft, allowing working stress of 63 MPa in tension and 42 MPa in shear for the material of shaft. Assume that the torque on one pulley is equal to that on the other pulley.

**Solution.** Given :  $AB = 800 \text{ mm}$  ;  $\alpha_C = 20^\circ$  ;  $D_C = 600 \text{ mm}$  or  $R_C = 300 \text{ mm}$  ;  $AC = 200 \text{ mm}$  ;  $D_D = 700 \text{ mm}$  or  $R_D = 350 \text{ mm}$  ;  $DB = 250 \text{ mm}$  ;  $\theta = 180^\circ = \pi \text{ rad}$  ;  $W = 2000 \text{ N}$  ;  $T_1 = 3000 \text{ N}$  ;  $T_1/T_2 = 3$  ;  $\tau = 40 \text{ MPa} = 40 \text{ N/mm}^2$

The space diagram of the shaft is shown in Fig (a).

We know that the torque acting on the shaft at  $D$ ,

$$\begin{aligned} T &= (T_1 - T_2) R_D = T_1 \left( 1 - \frac{T_2}{T_1} \right) R_D \\ &= 3000 \left( 1 - \frac{1}{3} \right) 350 = 700 \times 10^3 \text{ N-mm} \quad \dots (\because T_1/T_2 = 3) \end{aligned}$$

The torque diagram is shown in Fig. (b).

Assuming that the torque at  $D$  is equal to the torque at  $C$ , therefore the tangential force acting on the gear  $C$ ,

$$F_{tc} = \frac{T}{R_C} = \frac{700 \times 10^3}{300} = 2333 \text{ N}$$

and the normal load acting on the tooth of gear  $C$ ,

$$W_C = \frac{F_{tc}}{\cos \alpha_C} = \frac{2333}{\cos 20^\circ} = \frac{2333}{0.9397} = 2483 \text{ N}$$

The normal load acts at  $20^\circ$  to the vertical as shown in Fig. Resolving the normal load vertically and horizontally, we get

Vertical component of  $W_C$  i.e. the vertical load acting on the shaft at  $C$ ,

$$\begin{aligned} W_{CV} &= W_C \cos 20^\circ \\ &= 2483 \times 0.9397 = 2333 \text{ N} \end{aligned}$$

and horizontal component of  $W_C$  i.e. the horizontal load acting on the shaft at  $C$ ,

$$\begin{aligned} W_{CH} &= W_C \sin 20^\circ \\ &= 2483 \times 0.342 = 849 \text{ N} \end{aligned}$$

Since  $T_1/T_2 = 3$  and  $T_1 = 3000 \text{ N}$ , therefore

$$T_2 = T_1 / 3 = 3000 / 3 = 1000 \text{ N}$$

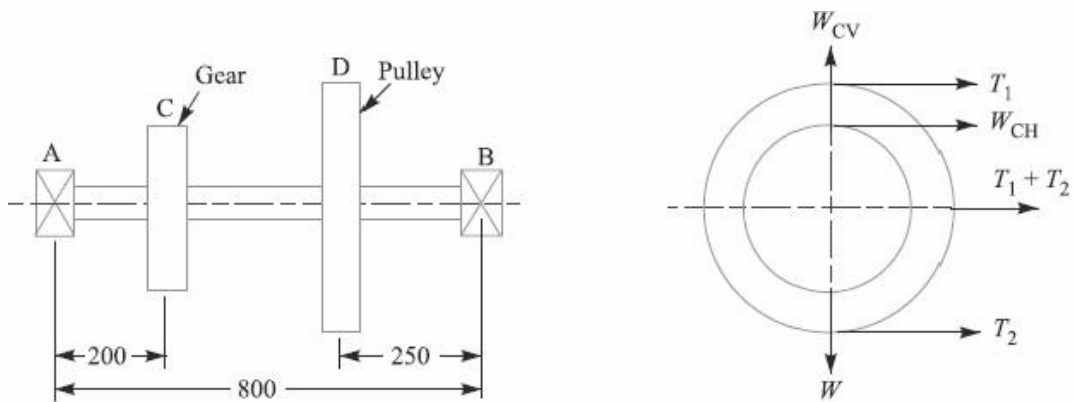

All dimensions in mm.  
(a) Space diagram.

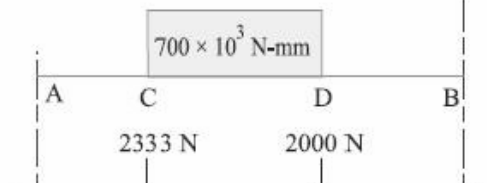

(b) Torque diagram.

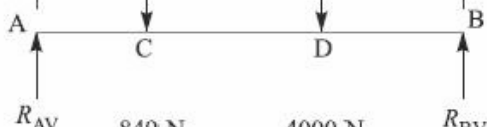

(c) Vertical load diagram.

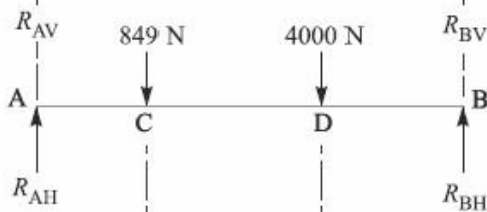

(d) Horizontal load diagram.

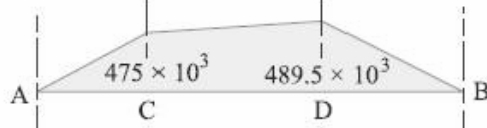

(e) Vertical B.M. diagram.



(f) Horizontal B.M. diagram.

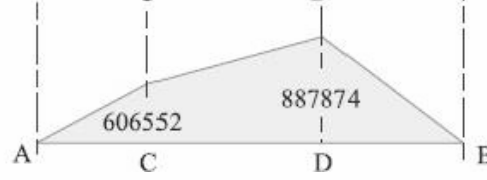

(g) Resultant B.M. diagram.

∴ Horizontal load acting on the shaft at D,

$$W_{DH} = T_1 + T_2 = 3000 + 1000 = 4000 \text{ N}$$

and vertical load acting on the shaft at D,

$$W_{DV} = W = 2000 \text{ N}$$

The vertical and horizontal load diagram at  $C$  and  $D$  is shown in Fig. 14.6 (c) and (d) respectively.

Now let us find the maximum bending moment for vertical and horizontal loading.

First of all considering the vertical loading at  $C$  and  $D$ . Let  $R_{AV}$  and  $R_{BV}$  be the reactions at the bearings  $A$  and  $B$  respectively. We know that

$$R_{AV} + R_{BV} = 2333 + 2000 = 4333 \text{ N}$$

Taking moments about  $A$ , we get

$$R_{BV} \times 800 = 2000 (800 - 250) + 2333 \times 200 \\ = 1\,565\,600$$

$$\therefore R_{BV} = 1\,565\,600 / 800 = 1958 \text{ N}$$

and  $R_{AV} = 4333 - 1958 = 2375 \text{ N}$

We know that B.M. at  $A$  and  $B$ ,

$$M_{AV} = M_{BV} = 0$$

B.M. at  $C$ ,  $M_{CV} = R_{AV} \times 200 = 2375 \times 200 \\ = 475 \times 10^3 \text{ N-mm}$

B.M. at  $D$ ,  $M_{DV} = R_{BV} \times 250 = 1958 \times 250 = 489.5 \times 10^3 \text{ N-mm}$

The bending moment diagram for vertical loading is shown in Fig. 14.6 (e).

Now consider the horizontal loading at  $C$  and  $D$ . Let  $R_{AH}$  and  $R_{BH}$  be the reactions at the bearings  $A$  and  $B$  respectively. We know that

$$R_{AH} + R_{BH} = 849 + 4000 = 4849 \text{ N}$$

Taking moments about  $A$ , we get

$$R_{BH} \times 800 = 4000 (800 - 250) + 849 \times 200 = 2\,369\,800$$

$$\therefore R_{BH} = 2\,369\,800 / 800 = 2963 \text{ N}$$

and  $R_{AH} = 4849 - 2963 = 1886 \text{ N}$

We know that B.M. at  $A$  and  $B$ ,

$$M_{AH} = M_{BH} = 0$$

B.M. at  $C$ ,  $M_{CH} = R_{AH} \times 200 = 1886 \times 200 = 377\,200 \text{ N-mm}$

B.M. at  $D$ ,  $M_{DH} = R_{BH} \times 250 = 2963 \times 250 = 740\,750 \text{ N-mm}$

The bending moment diagram for horizontal loading is shown in Fig. 14.6 (f).

We know that resultant B.M. at  $C$ ,

$$M_C = \sqrt{(M_{CV})^2 + (M_{CH})^2} = \sqrt{(475 \times 10^3)^2 + (377\,200)^2} \\ = 606\,552 \text{ N-mm}$$

and resultant B.M. at  $D$ ,

$$M_D = \sqrt{(M_{DV})^2 + (M_{DH})^2} = \sqrt{(489.5 \times 10^3)^2 + (740\,750)^2} \\ = 887\,874 \text{ N-mm}$$

*Maximum bending moment*

The resultant B.M. diagram is shown in Fig. 14.6 (g). We see that the bending moment is maximum at  $D$ , therefore

Maximum B.M.,  $M = M_D = 887\,874 \text{ N-mm Ans.}$

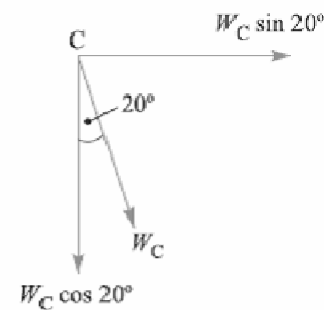

Fig. 14.7

### Diameter of the shaft

Let  $d$  = Diameter of the shaft.

We know that the equivalent twisting moment,

$$T_e = \sqrt{M^2 + T^2} = \sqrt{(887\ 874)^2 + (700 \times 10^3)^2} = 1131 \times 10^3 \text{ N-mm}$$

We also know that equivalent twisting moment ( $T_e$ ),

$$1131 \times 10^3 = \frac{\pi}{16} \times \tau \times d^3 = \frac{\pi}{16} \times 40 \times d^3 = 7.86 d^3$$

$$\therefore d^3 = 1131 \times 10^3 / 7.86 = 144 \times 10^3 \text{ or } d = 52.4 \text{ say } 55 \text{ mm Ans.}$$

### Problem:

A steel solid shaft transmitting 15 kW at 200 r.p.m. is supported on two bearings 750 mm apart and has two gears keyed to it. The pinion having 30 teeth of 5 mm module is located 100 mm to the left of the right hand bearing and delivers power horizontally to the right. The gear having 100 teeth of 5 mm module is located 150 mm to the right of the left hand bearing and receives power in a vertical direction from below. Using an allowable stress of 54 MPa in shear, determine the diameter of the shaft.

**Solution.** Given :  $P = 15 \text{ kW} = 15 \times 10^3 \text{ W}$  ;  $N = 200 \text{ r.p.m.}$  ;  $AB = 750 \text{ mm}$  ;  $T_D = 30$  ;  $m_D = 5 \text{ mm}$  ;  $BD = 100 \text{ mm}$  ;  $T_C = 100$  ;  $m_C = 5 \text{ mm}$  ;  $AC = 150 \text{ mm}$  ;  $\tau = 54 \text{ MPa} = 54 \text{ N/mm}^2$

The space diagram of the shaft is shown in Fig. 14.8 (a).

We know that the torque transmitted by the shaft,

$$T = \frac{P \times 60}{2\pi N} = \frac{15 \times 10^3 \times 60}{2\pi \times 200} = 716 \text{ N-m} = 716 \times 10^3 \text{ N-mm}$$

The torque diagram is shown in Fig. 14.8 (b).

We know that diameter of gear

$$= \text{No. of teeth on the gear} \times \text{module}$$

$\therefore$  Radius of gear C,

$$R_C = \frac{T_C \times m_C}{2} = \frac{100 \times 5}{2} = 250 \text{ mm}$$

and radius of pinion D,

$$R_D = \frac{T_D \times m_D}{2} = \frac{30 \times 5}{2} = 75 \text{ mm}$$

Assuming that the torque at C and D is same (i.e.  $716 \times 10^3 \text{ N-mm}$ ), therefore tangential force on the gear C, acting downward,

$$F_{tC} = \frac{T}{R_C} = \frac{716 \times 10^3}{250} = 2870 \text{ N}$$

and tangential force on the pinion D, acting horizontally,

$$F_{tD} = \frac{T}{R_D} = \frac{716 \times 10^3}{75} = 9550 \text{ N}$$

The vertical and horizontal load diagram is shown in Fig. 14.8 (c) and (d) respectively.

Now let us find the maximum bending moment for vertical and horizontal loading.

First of all, considering the vertical loading at C. Let  $R_{AV}$  and  $R_{BV}$  be the reactions at the bearings A and B respectively. We know that

$$R_{AV} + R_{BV} = 2870 \text{ N}$$

Taking moments about A, we get

$$R_{BV} \times 750 = 2870 \times 150$$

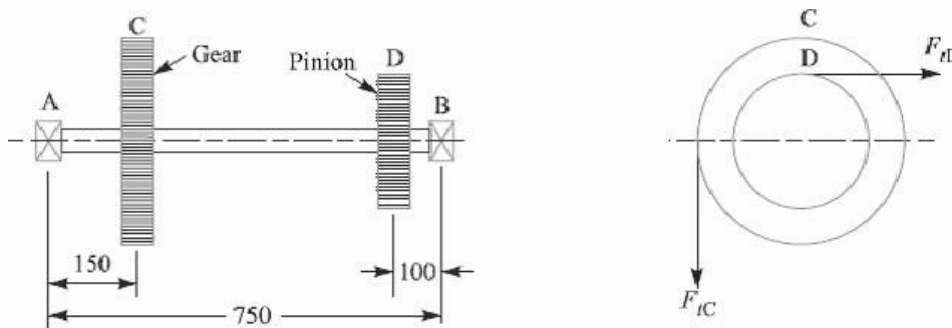

All dimensions in mm.

(a) Space diagram.

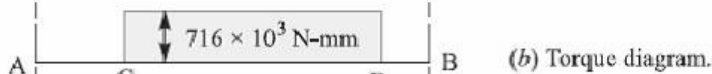

(b) Torque diagram.

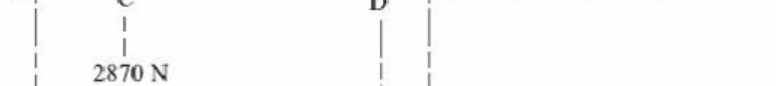

(c) Vertical load diagram.

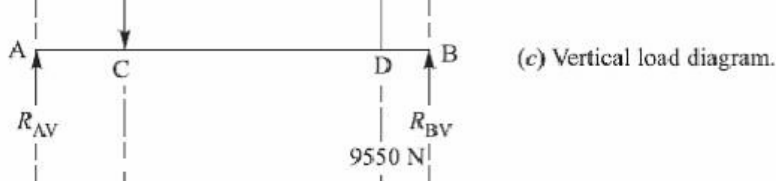

(d) Horizontal load diagram.

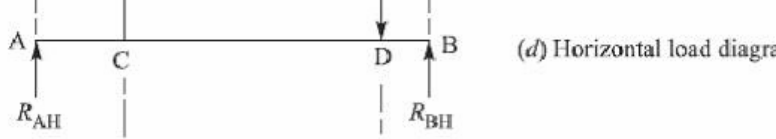

(e) Vertical B.M. diagram.

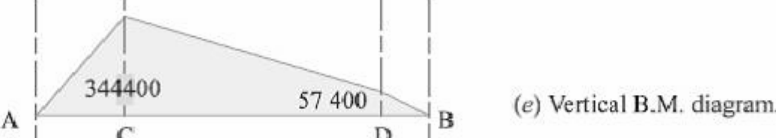

(f) Horizontal B.M. diagram.

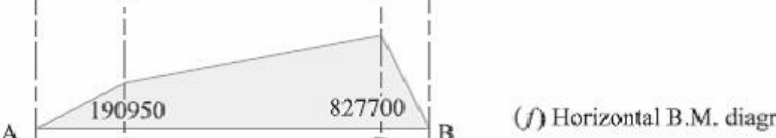

(g) Resultant B.M. diagram.

$$\therefore R_{BV} = 2870 \times 150 / 750 = 574 \text{ N}$$

and  $R_{AV} = 2870 - 574 = 2296 \text{ N}$

We know that B.M. at  $A$  and  $B$ ,

$$M_{AV} = M_{BV} = 0$$

B.M. at  $C$ ,  $M_{CV} = R_{AV} \times 150 = 2296 \times 150 = 344\,400 \text{ N-mm}$

B.M. at  $D$ ,  $M_{DV} = R_{BV} \times 100 = 574 \times 100 = 57\,400 \text{ N-mm}$

The B.M. diagram for vertical loading is shown in Fig. 14.8 (e).

Now considering horizontal loading at  $D$ . Let  $R_{AH}$  and  $R_{BH}$  be the reactions at the bearings  $A$  and  $B$  respectively. We know that

$$R_{AH} + R_{BH} = 9550 \text{ N}$$

Taking moments about  $A$ , we get

$$R_{BH} \times 750 = 9550 (750 - 100) = 9550 \times 650$$

$$\therefore R_{BH} = 9550 \times 650 / 750 = 8277 \text{ N}$$

and  $R_{AH} = 9550 - 8277 = 1273 \text{ N}$

We know that B.M. at  $A$  and  $B$ ,

$$M_{AH} = M_{BH} = 0$$

B.M. at  $C$ ,  $M_{CH} = R_{AH} \times 150 = 1273 \times 150 = 190\,950 \text{ N-mm}$

B.M. at  $D$ ,  $M_{DH} = R_{BH} \times 100 = 8277 \times 100 = 827\,700 \text{ N-mm}$

The B.M. diagram for horizontal loading is shown in Fig. 14.8 (f).

We know that resultant B.M. at  $C$ ,

$$M_C = \sqrt{(M_{CV})^2 + (M_{CH})^2} = \sqrt{(344\,400)^2 + (190\,950)^2}$$

$$= 393\,790 \text{ N-mm}$$

and resultant B.M. at  $D$ ,

$$M_D = \sqrt{(M_{DV})^2 + (M_{DH})^2} = \sqrt{(57\,400)^2 + (827\,700)^2}$$

$$= 829\,690 \text{ N-mm}$$

The resultant B.M. diagram is shown in Fig. 14.8 (g). We see that the bending moment is maximum at  $D$ .

$\therefore$  Maximum bending moment,

$$M = M_D = 829\,690 \text{ N-mm}$$

Let  $d$  = Diameter of the shaft.

We know that the equivalent twisting moment,

$$T_e = \sqrt{M^2 + T^2} = \sqrt{(829\,690)^2 + (716 \times 10^3)^2} = 1096 \times 10^3 \text{ N-mm}$$

We also know that equivalent twisting moment ( $T_e$ ),

$$1096 \times 10^3 = \frac{\pi}{16} \times \tau \times d^3 = \frac{\pi}{16} \times 54 \times d^3 = 10.6 d^3$$

$$\therefore d^3 = 1096 \times 10^3 / 10.6 = 103.4 \times 10^3$$

or  $d = 47$  say  $50 \text{ mm}$  Ans.

### **References:**

1. Machine Design - V. Bandari .

2. Machine Design – R.S. Khurmi
3. Design Data hand Book - S MD Jalaludin.



**Shafts Subjected to Axial Load in addition to Combined Torsion and Bending Loads:** When the shaft is subjected to an axial load ( $F$ ) in addition to torsion and bending loads as in propeller shafts of ships and shafts for driving worm gears, then the stress due to axial load must be added to the bending stress ( $\sigma_b$ ). We know that bending equation is

$$\frac{M}{I} = \frac{\sigma_b}{y} \quad \text{or} \quad \sigma_b = \frac{M \cdot y}{I} = \frac{M \times d/2}{\frac{\pi}{64} \times d^4} = \frac{32M}{\pi d^3}$$

And stress due to axial load

$$= \frac{F}{\frac{\pi}{4} \times d^2} = \frac{4F}{\pi d^2} \quad \dots (\text{For round solid shaft})$$

$$= \frac{F}{\frac{\pi}{4} [(d_o)^2 - (d_i)^2]} = \frac{4F}{\pi [(d_o)^2 - (d_i)^2]} \quad \dots (\text{For hollow shaft})$$

$$= \frac{F}{\pi (d_o)^2 (1 - k^2)} \quad \dots (\because k = d_i/d_o)$$

Resultant stress (tensile or compressive) for solid shaft,

$$\sigma_1 = \frac{32M}{\pi d^3} + \frac{4F}{\pi d^2} = \frac{32}{\pi d^3} \left( M + \frac{F \times d}{8} \right) \quad \dots (i)$$

$$= \frac{32M_1}{\pi d^3} \quad \dots \left( \text{Substituting } M_1 = M + \frac{F \times d}{8} \right)$$

In case of a hollow shaft, the resultant stress,

$$\begin{aligned} \sigma_1 &= \frac{32M}{\pi (d_o)^3 (1 - k^4)} + \frac{4F}{\pi (d_o)^2 (1 - k^2)} \\ &= \frac{32}{\pi (d_o)^3 (1 - k^4)} \left[ M + \frac{F d_o (1 + k^2)}{8} \right] = \frac{32M_1}{\pi (d_o)^3 (1 - k^4)} \end{aligned}$$

In case of long shafts (slender shafts) subjected to compressive loads, a factor known as **column factor** ( $\alpha$ ) must be introduced to take the column effect into account.

Therefore, Stress due to the compressive load,

$$\sigma_c = \frac{\alpha \times 4F}{\pi d^2}$$

or

$$= \frac{\alpha \times 4F}{\pi(d_o)^2 (1 - k^2)}$$

The value of column factor ( $\alpha$ ) for compressive loads\* may be obtained from the following relation :

Column factor,

$$\alpha = \frac{1}{1 - 0.0044 (L/K)}$$

This expression is used when the slenderness ratio ( $L/K$ ) is less than 115. When the slenderness ratio ( $L/K$ ) is more than 115, then the value of column factor may be obtained from the following relation:

Column factor,  $\alpha$

$$\alpha = \frac{\sigma_y (L/K)^2}{C \pi^2 E}$$

Where  $L$  = Length of shaft between the bearings,

$K$  = Least radius of gyration,

$\sigma_y$  = Compressive yield point stress of shaft material, and

$C$  = Coefficient in Euler's formula depending upon the end conditions.

The following are the different values of  $C$  depending upon the end conditions.

$C = 1$ , for hinged ends,

$C = 2.25$ , for fixed ends,

$C = 1.6$ , for ends that are partly restrained as in bearings.

In general, for a hollow shaft subjected to fluctuating torsional and bending load, along with an axial load, the equations for equivalent twisting moment ( $T_e$ ) and equivalent bending moment ( $M_e$ ) may be written as

$$T_e = \sqrt{\left[ K_m \times M + \frac{\alpha F d_o (1 + k^2)}{8} \right]^2 + (K_t \times T)^2}$$

$$= \frac{\pi}{16} \times \tau (d_o)^3 (1 - k^4)$$

$$M_e = \frac{1}{2} \left[ K_m \times M + \frac{\alpha F d_o (1 + k^2)}{8} + \sqrt{\left\{ K_m \times M + \frac{\alpha F d_o (1 + k^2)}{8} \right\}^2 + (K_t \times T)^2} \right]$$

$$= \frac{\pi}{32} \times \sigma_b (d_o)^3 (1 - k^4)$$

It may be noted that for a solid shaft,  $k = 0$  and  $d_o = d$ . When the shaft carries no axial load, then  $F = 0$  and when the shaft carries axial tensile load, then  $\alpha = 1$ .

**References:**

1. Machine Design - V.Bandari .
2. Machine Design – R.S. Khurmi
3. Design Data hand Book - S MD Jalaludin.

Problem:

A hollow shaft is subjected to a maximum torque of 1.5 kN-m and a maximum bending moment of 3 kN-m. It is subjected, at the same time, to an axial load of 10 kN. Assume that the load is applied gradually and the ratio of the inner diameter to the outer diameter is 0.5. If the outer diameter of the shaft is 80 mm, find the shear stress induced in the shaft.

**Solution.** Given:  $T = 1.5 \text{ kN-m} = 1.5 \times 10^3 \text{ N-m}$ ;  $M = 3 \text{ kN-m} = 3 \times 10^3 \text{ N-m}$ ;

$F = 10 \text{ kN} = 10 \times 10^3 \text{ N}$ ;  $k = d_i / d_o = 0.5$ ;  $d_o = 80 \text{ mm} = 0.08 \text{ m}$

Let  $\tau$  = Shear stress induced in the shaft.

Since the load is applied gradually, therefore from DDB, we find that  $K_m = 1.5$ ; and  $K_t = 1.0$

We know that the equivalent twisting moment for a hollow shaft,

$$\begin{aligned} T_e &= \sqrt{\left[ K_m \times M + \frac{\alpha F d_o (1 + k^2)^2}{8} \right]^2 + (K_t \times T)^2} \\ &= \sqrt{\left[ 1.5 \times 3 \times 10^3 + \frac{1 \times 10 \times 10^3 \times 0.08 (1 + 0.5^2)^2}{8} \right]^2 + (1 \times 1.5 \times 10^3)^2} \\ &= \sqrt{(4500 + 125)^2 + (1500)^2} = 4862 \text{ N-m} = 4862 \times 10^3 \text{ N-mm} \end{aligned}$$

We also know that the equivalent twisting moment for a hollow shaft ( $T_e$ ),

$$\begin{aligned} 4862 \times 10^3 &= \frac{\pi}{16} \times \tau (d_o)^3 (1 - k^4) = \frac{\pi}{16} \times \tau (80)^3 (1 - 0.5^4) = 94\,260 \tau \\ \therefore \tau &= 4862 \times 10^3 / 94\,260 = 51.6 \text{ N/mm}^2 = 51.6 \text{ MPa Ans.} \end{aligned}$$

Problem:

A hollow shaft of 0.5 m outside diameter and 0.3 m inside diameter is used to drive a propeller of a marine vessel. The shaft is mounted on bearings 6 metre apart and it transmits 5600 kW at 150 r.p.m. The maximum axial propeller thrust is 500 kN and the shaft weighs 70 kN.

Determine:

1. The maximum shear stress developed in the shaft, and
2. The angular twist between the bearings.

**Solution.** Given :  $d_o = 0.5 \text{ m}$  ;  $d_i = 0.3 \text{ m}$  ;  $P = 5600 \text{ kW} = 5600 \times 10^3 \text{ W}$  ;  $L = 6 \text{ m}$  ;  
 $N = 150 \text{ r.p.m.}$  ;  $F = 500 \text{ kN} = 500 \times 10^3 \text{ N}$  ;  $W = 70 \text{ kN} = 70 \times 10^3 \text{ N}$

1. *Maximum shear stress developed in the shaft*

Let  $\tau$  = Maximum shear stress developed in the shaft.

We know that the torque transmitted by the shaft,

$$T = \frac{P \times 60}{2\pi N} = \frac{5600 \times 10^3 \times 60}{2\pi \times 150} = 356\,460 \text{ N-m}$$

and the maximum bending moment,

$$M = \frac{W \times L}{8} = \frac{70 \times 10^3 \times 6}{8} = 52\,500 \text{ N-m}$$

Now let us find out the column factor  $\alpha$ . We know that least radius of gyration,

$$\begin{aligned} K &= \sqrt{\frac{I}{A}} = \sqrt{\frac{\frac{\pi}{64} [(d_o)^4 - (d_i)^4]}{\frac{\pi}{4} [(d_o)^2 - (d_i)^2]}} \\ &= \sqrt{\frac{[(d_o)^2 + (d_i)^2][(d_o)^2 - (d_i)^2]}{16 [(d_o)^2 - (d_i)^2]}} \\ &= \frac{1}{4} \sqrt{(d_o)^2 + (d_i)^2} = \frac{1}{4} \sqrt{(0.5)^2 + (0.3)^2} = 0.1458 \text{ m} \end{aligned}$$

$\therefore$  Slenderness ratio,

$$L / K = 6 / 0.1458 = 41.15$$

and column factor,

$$\begin{aligned} \alpha &= \frac{1}{1 - 0.0044 \left(\frac{L}{K}\right)^2} \quad \dots \left(\because \frac{L}{K} < 115\right) \\ &= \frac{1}{1 - 0.0044 \times 41.15^2} = \frac{1}{1 - 0.18} = 1.22 \end{aligned}$$

Assuming that the load is applied gradually, therefore from Table 14.2, we find that

$$K_m = 1.5 \text{ and } K_t = 1.0$$

Also

$$k = d_i / d_o = 0.3 / 0.5 = 0.6$$

We know that the equivalent twisting moment for a hollow shaft,

$$\begin{aligned} T_e &= \sqrt{\left[ K_m \times M + \frac{\alpha F d_o (1 + k^2)}{8} \right]^2 + (K_t \times T)^2} \\ &= \sqrt{\left[ 1.5 \times 52\,500 + \frac{1.22 \times 500 \times 10^3 \times 0.5 (1 + 0.6^2)}{8} \right]^2 + (1 \times 356\,460)^2} \\ &= \sqrt{(78\,750 + 51\,850)^2 + (356\,460)^2} = 380 \times 10^3 \text{ N-m} \end{aligned}$$

We also know that the equivalent twisting moment for a hollow shaft ( $T_e$ ),

$$380 \times 10^3 = \frac{\pi}{16} \times \tau (d_o)^3 (1 - k^4) = \frac{\pi}{16} \times \tau (0.5)^3 [1 - (0.6)^4] = 0.02 \tau$$

$$\therefore \tau = 380 \times 10^3 / 0.02 = 19 \times 10^6 \text{ N/m}^2 = 19 \text{ MPa Ans.}$$

## 2. Angular twist between the bearings

Let  $\theta$  = Angular twist between the bearings in radians.

We know that the polar moment of inertia for a hollow shaft,

$$J = \frac{\pi}{32} [(d_o)^4 - (d_i)^4] = \frac{\pi}{32} [(0.5)^4 - (0.3)^4] = 0.00534 \text{ m}^4$$

From the torsion equation,

$$\frac{T}{J} = \frac{G \times \theta}{L}, \text{ we have}$$

$$\theta = \frac{T \times L}{G \times J} = \frac{356460 \times 6}{84 \times 10^9 \times 0.00534} = 0.0048 \text{ rad}$$

... (Taking  $G = 84 \text{ GPa} = 84 \times 10^9 \text{ N/m}^2$ )

$$= 0.0048 \times \frac{180}{\pi} = 0.275^\circ \text{ Ans.}$$

### **References:**

1. Machine Design - V. Bandari .
2. Machine Design – R.S. Khurmi
3. Design Data hand Book - S MD Jalaludin.

### **Design of Shafts on the basis of Rigidity**

Sometimes the shafts are to be designed on the basis of rigidity. We shall consider the following two types of rigidity.

**1. Torsional rigidity.** The torsional rigidity is important in the case of camshaft of an I.C. engine where the timing of the valves would be affected. The permissible amount of twist should not exceed  $0.25^\circ$  per metre length of such shafts. For line shafts or transmission shafts, deflections 2.5 to 3 degree per metre length may be used as limiting value. The widely used deflection for the shafts is limited to 1 degree in a length equal to twenty times the diameter of the shaft. The torsional deflection may be obtained by using the torsion equation,

$$\frac{T}{J} = \frac{G \cdot \theta}{L} \quad \text{or} \quad \theta = \frac{T \cdot L}{J \cdot G}$$

where  $\theta$  = Torsional deflection or angle of twist in radians,

T = Twisting moment or torque on the shaft,

J = Polar moment of inertia of the cross-sectional area about the axis of rotation,

G = Modulus of rigidity for the shaft material, and

L = Length of the shaft.

**2. Lateral rigidity.** It is important in case of transmission shafting and shafts running at high speed, where small lateral deflection would cause huge out-of-balance forces. The lateral rigidity is also important for maintaining proper bearing clearances and for correct gear teeth alignment. If the shaft is of uniform cross-section, then the lateral deflection of a shaft may be obtained by using the deflection formulae as in Strength of Materials. But when the shaft is of variable cross-section, then the lateral deflection may be determined from the fundamental equation for the elastic curve of a beam, *i.e.*

$$\frac{d^2y}{dx^2} = \frac{M}{EI}$$

### **BIS codes of Shafts**

The standard sizes of transmission shafts are:

25 mm to 60 mm with 5 mm steps; 60 mm to 110 mm with 10 mm steps ; 110 mm to 140 mm with 15 mm steps ; and 140 mm to 500 mm with 20 mm steps. The standard length of the shafts are 5 m, 6 m and 7 m.

:

**References:**

1. Machine Design - V.Bandari .
2. Machine Design – R.S. Khurmi
3. Design Data hand Book - S MD Jalaludin.



**Problem:**

A steel spindle transmits 4 kW at 800 r.p.m. The angular deflection should not exceed  $0.25^\circ$  per metre of the spindle. If the modulus of rigidity for the material of the spindle is 84 GPa, find the diameter of the spindle and the shear stress induced in the spindle.

**Solution.** Given :  $P = 4 \text{ kW} = 4000 \text{ W}$  ;  $N = 800 \text{ r.p.m.}$  ;  $\theta = 0.25^\circ = 0.25 \times \frac{\pi}{180} = 0.0044 \text{ rad}$  ;  
 $L = 1 \text{ m} = 1000 \text{ mm}$  ;  $G = 84 \text{ GPa} = 84 \times 10^9 \text{ N/m}^2 = 84 \times 10^3 \text{ N/mm}^2$

*Diameter of the spindle*

Let  $d = \text{Diameter of the spindle in mm.}$

We know that the torque transmitted by the spindle,

$$T = \frac{P \times 60}{2\pi N} = \frac{4000 \times 60}{2\pi \times 800} = 47.74 \text{ N-m} = 47\,740 \text{ N-mm}$$

We also know that  $\frac{T}{J} = \frac{G \times \theta}{L}$  or  $J = \frac{T \times l}{G \times \theta}$

or  $\frac{\pi}{32} \times d^4 = \frac{47\,740 \times 1000}{84 \times 10^3 \times 0.0044} = 129\,167$

$\therefore d^4 = 129\,167 \times 32 / \pi = 1.3 \times 10^6$  or  $d = 33.87$  say  $35 \text{ mm Ans.}$

*Shear stress induced in the spindle*

Let  $\tau = \text{Shear stress induced in the spindle.}$

We know that the torque transmitted by the spindle ( $T$ ),

$$47\,740 = \frac{\pi}{16} \times \tau \times d^3 = \frac{\pi}{16} \times \tau (35)^3 = 8420 \tau$$

$\therefore \tau = 47\,740 / 8420 = 5.67 \text{ N/mm}^2 = 5.67 \text{ MPa Ans.}$

### **References:**

1. Machine Design - V.Bandari .
2. Machine Design – R.S. Khurmi
3. Design Data hand Book - S MD Jalaludin.

Use of internal and external circlips, Gaskets and seals

**References:**

1. Machine Design - V.Bandari .
2. Machine Design – R.S. Khurmi
3. Design Data hand Book - S MD Jalaludin.

Problems:

Compare the weight, strength and stiffness of a hollow shaft of the same external diameter as that of solid shaft. The inside diameter of the hollow shaft being half the external diameter. Both the shafts have the same material and length.

**Solution.** Given :  $d_o = d$  ;  $d_i = d_o / 2$  or  $k = d_i / d_o = 1 / 2 = 0.5$

#### Comparison of weight

We know that weight of a hollow shaft,

$$\begin{aligned} W_H &= \text{Cross-sectional area} \times \text{Length} \times \text{Density} \\ &= \frac{\pi}{4} [(d_o)^2 - (d_i)^2] \times \text{Length} \times \text{Density} \end{aligned} \quad \dots(i)$$

and weight of the solid shaft,

$$W_S = \frac{\pi}{4} \times d^2 \times \text{Length} \times \text{Density} \quad \dots(ii)$$

Since both the shafts have the same material and length, therefore by dividing equation (i) by equation (ii), we get

$$\begin{aligned} \frac{W_H}{W_S} &= \frac{(d_o)^2 - (d_i)^2}{d^2} = \frac{(d_o)^2 - (d_i)^2}{(d_o)^2} \quad \dots(\because d = d_o) \\ &= 1 - \frac{(d_i)^2}{(d_o)^2} = 1 - k^2 = 1 - (0.5)^2 = 0.75 \text{ Ans.} \end{aligned}$$

#### Comparison of strength

We know that strength of the hollow shaft,

$$T_H = \frac{\pi}{16} \times \tau (d_o)^3 (1 - k^4) \quad \dots(iii)$$

and strength of the solid shaft,

$$T_S = \frac{\pi}{16} \times \tau \times d^3 \quad \dots(iv)$$

Dividing equation (iii) by equation (iv), we get

$$\begin{aligned} \frac{T_H}{T_S} &= \frac{(d_o)^3 (1 - k^4)}{d^3} = \frac{(d_o)^3 (1 - k^4)}{(d_o)^3} = 1 - k^4 \quad \dots(\because d = d_o) \\ &= 1 - (0.5)^4 = 0.9375 \text{ Ans.} \end{aligned}$$

#### Comparison of stiffness

We know that stiffness

$$= \frac{T}{\theta} = \frac{G \times J}{L}$$

$\therefore$  Stiffness of a hollow shaft,

$$S_H = \frac{G}{L} \times \frac{\pi}{32} [(d_o)^4 - (d_i)^4] \quad \dots(v)$$

and stiffness of a solid shaft,

$$S_s = \frac{G}{L} \times \frac{\pi}{32} \times d^4 \quad \dots(vi)$$

Dividing equation (v) by equation (vi), we get

$$\begin{aligned} \frac{S_H}{S_s} &= \frac{(d_o)^4 - (d_i)^4}{d^4} = \frac{(d_o)^4 - (d_i)^4}{(d_o)^4} = 1 - \frac{(d_i)^4}{(d_o)^4} \quad \dots(\because d = d_o) \\ &= 1 - k^4 = 1 - (0.5)^4 = 0.9375 \text{ Ans.} \end{aligned}$$

**References:**

1. Machine Design - V.Bandari .
2. Machine Design – R.S. Khurmi
3. Design Data hand Book - S MD Jalaludin.

## **Shaft Coupling**

Shafts are usually available up to 7 meters length due to inconvenience in transport. In order to have a greater length, it becomes necessary to join two or more pieces of the shaft by means of a coupling.

Shaft couplings are used in machinery for several purposes, the most common of which are the following:

1. To provide for the connection of shafts of units those are manufactured separately such as a motor and generator and to provide for disconnection for repairs or alternations.
2. To provide for misalignment of the shafts or to introduce mechanical flexibility.
3. To reduce the transmission of shock loads from one shaft to another.
4. To introduce protection against overloads.
5. It should have no projecting parts.

## **Types of Shafts Couplings**

Shaft couplings are divided into two main groups as follows:

**1. Rigid coupling.** It is used to connect two shafts which are perfectly aligned. Following types of rigid coupling are important from the subject point of view:

- (a) Sleeve or muff coupling.
- (b) Clamp or split-muff or compression coupling, and
- (c) Flange coupling.

**2. Flexible coupling.** It is used to connect two shafts having both lateral and angular misalignment. Following types of flexible coupling are important from the subject point of view:

- (a) Bushed pin type coupling,
- (b) Universal coupling, and
- (c) Oldham coupling.

## **Sleeve or Muff-coupling**

It is the simplest type of rigid coupling, made of cast iron. It consists of a hollow cylinder whose inner diameter is the same as that of the shaft. It is fitted over the ends of the two shafts by means of a gib head key, as shown in Fig. The power is transmitted from one shaft to the other shaft by means of a key and a sleeve. It is, therefore, necessary that all the elements must be strong enough to transmit the torque. The usual proportions of a cast iron sleeve coupling are as follows:

Outer diameter of the sleeve,  $D = 2d + 13 \text{ mm}$

And length of the sleeve,  $L = 3.5 d$

Where  $d$  is the diameter of the shaft.

In designing a sleeve or muff-coupling, the following procedure may be adopted.

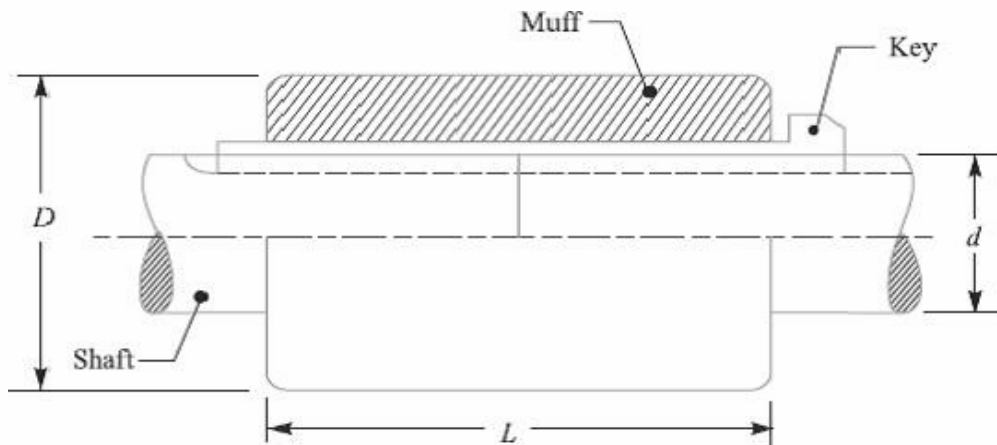

### 1. Design for sleeve

The sleeve is designed by considering it as a hollow shaft

Let  $T$  = Torque to be transmitted by the coupling, and

$\tau_c$  = Permissible shear stress for the material of the sleeve which is cast iron.

The safe value of shear stress for cast iron may be taken as 14 MPa.

We know that torque transmitted by a hollow section,

$$T = \frac{\pi}{16} \times \tau_c \left( \frac{D^4 - d^4}{D} \right) = \frac{\pi}{16} \times \tau_c \times D^3 (1 - k^4) \quad \dots (\because k = d/D)$$

From this expression, the induced shear stress in the sleeve may be checked.

### 2. Design for key

The key for the coupling may be designed in the similar way as discussed in Unit-5. The width and thickness of the coupling key is obtained from the proportions. The length of the coupling key is at least equal to the length of the sleeve (i.e.  $3.5 d$ ). The coupling key is usually made into two parts so that the length of the key in each shaft,

$$l = \frac{L}{2} = \frac{3.5 d}{2}$$

After fixing the length of key in each shaft, the induced shearing and crushing stresses may be checked. We know that torque transmitted,

$$T = l \times w \times \tau \times \frac{d}{2} \quad \dots \text{... (Considering shearing of the key)}$$

$$= l \times \frac{t}{2} \times \sigma_c \times \frac{d}{2} \quad \dots \text{... (Considering crushing of the key)}$$

**Note:** The depth of the keyway in each of the shafts to be connected should be exactly the same and the diameters should also be same. If these conditions are not satisfied, then the key will be bedded on one shaft while in the other it will be loose. In order to prevent this, the key is made in two parts which may be driven from the same end for each shaft or they may be driven from opposite ends.

**References:**

1. Machine Design - V.Bandari .
2. Machine Design – R.S. Khurmi
3. Design Data hand Book - S MD Jalaludin.

Problem: Design and make a neat dimensioned sketch of a muff coupling which is used to connect two steel shafts transmitting 40 kW at 350 r.p.m. The material for the shafts and key is plain carbon steel for which allowable shear and crushing stresses may be taken as 40 MPa and 80 MPa respectively. The material for the muff is cast iron for which the allowable shear stress may be assumed as 15 MPa.

**Solution.**

Given:  $P = 40 \text{ kW} = 40 \times 10^3 \text{ W}$ ;  $N = 350 \text{ r.p.m.}$ ;  $\tau_s = 40 \text{ MPa} = 40 \text{ N/mm}^2$ ;  $\sigma_{cs} = 80 \text{ MPa} = 80 \text{ N/mm}^2$ ;  $\sigma_c = 15 \text{ MPa} = 15 \text{ N/mm}^2$ .

$$T = \frac{P \times 60}{2 \pi N} = \frac{40 \times 10^3 \times 60}{2 \pi \times 350} = 1100 \text{ N-m}$$

$$= 1100 \times 10^3 \text{ N-mm}$$

We also know that the torque transmitted ( $T$ ),

$$1100 \times 10^3 = \frac{\pi}{16} \times \tau_s \times d^3 = \frac{\pi}{16} \times 40 \times d^3 = 7.86 d^3$$

$$\therefore d^3 = 1100 \times 10^3 / 7.86 = 140 \times 10^3 \text{ or } d = 52 \text{ say } 55 \text{ mm Ans.}$$

**2. Design for sleeve**

We know that outer diameter of the muff,

$$D = 2d + 13 \text{ mm} = 2 \times 55 + 13 = 123 \text{ say } 125 \text{ mm Ans.}$$

and length of the muff,

$$L = 3.5 d = 3.5 \times 55 = 192.5 \text{ say } 195 \text{ mm Ans.}$$

Let us now check the induced shear stress in the muff. Let  $\tau_c$  be the induced shear stress in the muff which is made of cast iron. Since the muff is considered to be a hollow shaft, therefore the torque transmitted ( $T$ ),

$$1100 \times 10^3 = \frac{\pi}{16} \times \tau_c \left( \frac{D^4 - d^4}{D} \right) = \frac{\pi}{16} \times \tau_c \left[ \frac{(125)^4 - (55)^4}{125} \right]$$

$$= 370 \times 10^3 \tau_c$$

$$\therefore \tau_c = 1100 \times 10^3 / 370 \times 10^3 = 2.97 \text{ N/mm}^2$$

Since the induced shear stress in the muff (cast iron) is less than the permissible shear stress of 15 N/mm<sup>2</sup>, therefore the design of muff is safe.

**3. Design for key**

From Design data Book, we find that for a shaft of 55 mm diameter,

$$\text{Width of key, } w = 18 \text{ mm Ans.}$$



Since the crushing stress for the key material is twice the shearing stress, therefore a square key may be used.

Then, Thickness of key,  $t = w = 18 \text{ mm}$  **Ans.**

We know that length of key in each shaft,

$$l = L / 2 = 195 / 2 = 97.5 \text{ mm} \text{ **Ans.**}$$

Let us now check the induced shear and crushing stresses in the key. First of all, let us consider shearing of the key. We know that torque transmitted ( $T$ ),

$$1100 \times 10^3 = l \times w \times \tau_s \times \frac{d}{2} = 97.5 \times 18 \times \tau_s \times \frac{55}{2} = 48.2 \times 10^3 \tau_s$$
$$\tau_s = 1100 \times 10^3 / 48.2 \times 10^3 = 22.8 \text{ N/mm}^2$$

Now considering crushing of the key. We know that torque transmitted ( $T$ ),

$$1100 \times 10^3 = l \times \frac{t}{2} \times \sigma_{cs} \times \frac{d}{2} = 97.5 \times \frac{18}{2} \times \sigma_{cs} \times \frac{55}{2} = 24.1 \times 10^3 \sigma_{cs}$$
$$\sigma_{cs} = 1100 \times 10^3 / 24.1 \times 10^3 = 45.6 \text{ N/mm}^2$$

Since the induced shear and crushing stresses are less than the permissible stresses, therefore the design of key is safe.

### **References:**

1. Machine Design - V. Bandari .
2. Machine Design – R.S. Khurmi
3. Design Data hand Book - S MD Jalaludin.

### **Clamp or Compression Coupling or split muff coupling**

It is also known as **split muff coupling**. In this case, the muff or sleeve is made into two halves and are bolted together as shown in Fig. The halves of the muff are made of cast iron. The shaft ends are made to a butt each other and a single key is fitted directly in the keyways of both the shafts. One-half of the muff is fixed from below and the other half is placed from above. Both the halves are held together by means of mild steel studs or bolts and nuts. The number of bolts may be two, four or six. The nuts are recessed into the bodies of the muff castings. This coupling may be used for heavy duty and moderate speeds. The advantage of this coupling is that the position of the shafts need not be changed for assembling or disassembling of the coupling. The usual proportions of the muff for the clamp or compression coupling are:

$$\text{Diameter of the muff or sleeve, } D = 2d + 13 \text{ mm}$$

$$\text{Length of the muff or sleeve, } L = 3.5 d$$

Where  $d$  = Diameter of the shaft.

In the clamp or compression coupling, the power is transmitted from one shaft to the other by means of key and the friction between the muff and shaft. In designing this type of coupling, the following procedure may be adopted.

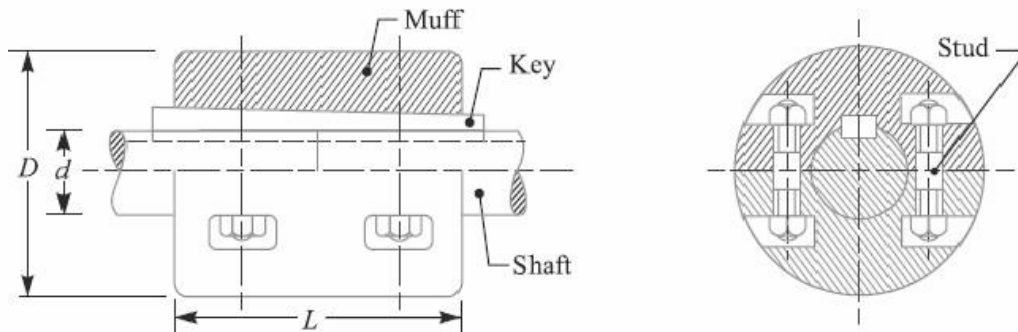

#### **1. Design of muff and key**

The muff and key are designed in the similar way as discussed in muff coupling.

#### **2. Design of clamping bolts**

Let  $T$  = Torque transmitted by the shaft,

$d$  = Diameter of shaft,

$d_b$  = Root or effective diameter of bolt,

$n$  = Number of bolts,

$\sigma_t$  = Permissible tensile stress for bolt material,

$\mu$  = Coefficient of friction between the muff and shaft, and

$L$  = Length of muff.

We know that the force exerted by each bolt

$$= \frac{\pi}{4} (d_b)^2 \sigma_t$$

Then, Force exerted by the bolts on each side of the shaft

$$= \frac{\pi}{4} (d_b)^2 \sigma_t \times \frac{n}{2}$$

Let  $p$  be the pressure on the shaft and the muff surface due to the force, then for uniform pressure distribution over the surface,

$$p = \frac{\text{Force}}{\text{Projected area}} = \frac{\frac{\pi}{4} (d_b)^2 \sigma_t \times \frac{n}{2}}{\frac{1}{2} L \times d}$$

Then, Frictional force between each shaft and muff,

$$\begin{aligned} F &= \mu \times \text{pressure} \times \text{area} = \mu \times p \times \frac{1}{2} \times \pi d \times L \\ &= \mu \times \frac{\frac{\pi}{4} (d_b)^2 \sigma_t \times \frac{n}{2}}{\frac{1}{2} L \times d} \times \frac{1}{2} \pi d \times L \\ &= \mu \times \frac{\pi}{4} (d_b)^2 \sigma_t \times \frac{n}{2} \times \pi = \mu \times \frac{\pi^2}{8} (d_b)^2 \sigma_t \times n \end{aligned}$$

And the torque that can be transmitted by the coupling,

$$T = F \times \frac{d}{2} = \mu \times \frac{\pi^2}{8} (d_b)^2 \sigma_t \times n \times \frac{d}{2} = \frac{\pi^2}{16} \times \mu (d_b)^2 \sigma_t \times n \times d$$

From this relation, the root diameter of the bolt ( $d_b$ ) may be evaluated.

### **Flange Coupling**

A flange coupling usually applies to a coupling having two separate cast iron flanges. Each flange is mounted on the shaft end and keyed to it. The faces are turned up at right angle to the axis of the shaft. One of the flanges has a projected portion and the other flange has a corresponding recess. This helps to bring the shafts into line and to maintain alignment. The two flanges are coupled together by means of bolts and nuts. The flange coupling is adapted to heavy loads and hence it is used on large shafting.

The flange couplings are of the following three types:

**1. Unprotected type flange coupling.** In an unprotected type flange coupling, as shown in Fig.1, each shaft is keyed to the boss of a flange with a counter sunk key and the flanges are coupled together by means of bolts. Generally, three, four or six bolts are used. The keys are staggered at right angle along the circumference of the shafts in order to divide the weakening effect caused by keyways.

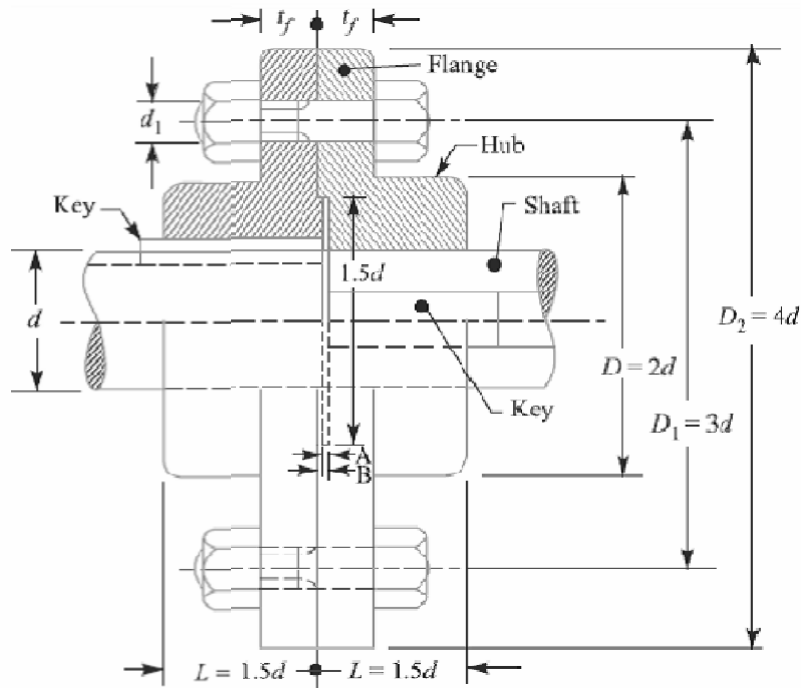

Fig.1 Unprotected Type Flange Coupling.

The usual proportions for an unprotected type cast iron flange couplings, as shown in Fig.1, are as follows:

If  $d$  is the diameter of the shaft or inner diameter of the hub, then Outside diameter of hub,

$$D = 2d$$

$$\text{Length of hub, } L = 1.5d$$

$$\text{Pitch circle diameter of bolts, } D_1 = 3d$$

Outside diameter of flange,

$$D_2 = D_1 + (D_1 - D) = 2D_1 - D = 4d$$

Thickness of flange,  $t_f = 0.5d$

Number of bolts = 3, for  $d$  upto 40 mm

= 4, for  $d$  upto 100 mm

= 6, for  $d$  upto 180 mm

**2. Protected type flange coupling.** In a protected type flange coupling, as shown in Fig.2, the protruding bolts and nuts are protected by flanges on the two halves of the coupling, in order to avoid danger to the workman. The thickness of the protective circumferential flange ( $t_p$ ) is taken as  $0.25 d$ . The other proportions of the coupling are same as for unprotected type flange coupling.

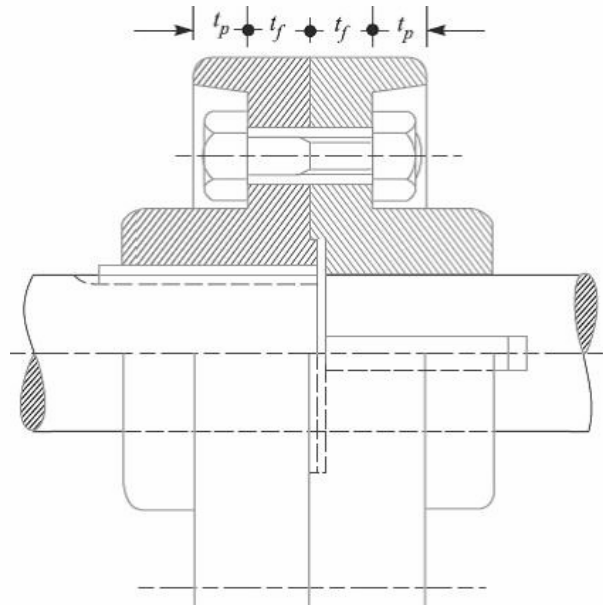

Fig.2. Protected Type Flange Coupling.

**3. Marine type flange coupling.** In a marine type flange coupling, the flanges are forged integral with the shafts as shown in Fig.3.

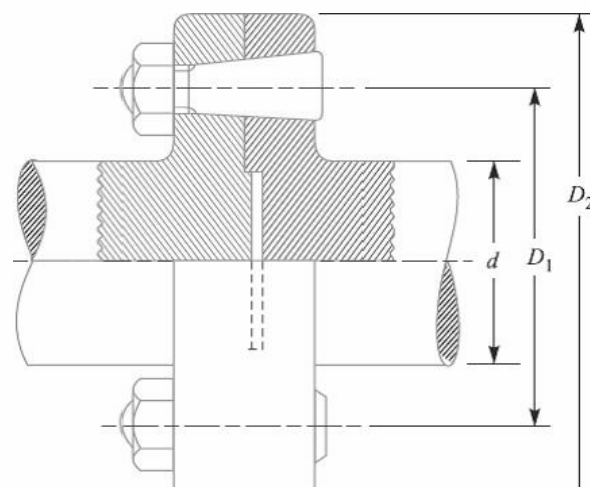

Fig.3. Solid Flange Coupling or Marine Type flange coupling.

The flanges are held together by means of tapered headless bolts, numbering from four to twelve depending upon the diameter of shaft. The other proportions for the marine type flange coupling are taken as follows:

Thickness of flange =  $d / 3$

Taper of bolt = 1 in 20 to 1 in 40

Pitch circle diameter of bolts,  $D_1 = 1.6 d$

Outside diameter of flange,  $D_2 = 2.2 d$

### **Design of Flange Coupling**

Consider a flange coupling as shown in Fig.1 and Fig.2.

Let  $d$  = Diameter of shaft or inner diameter of hub,

$D$  = Outer diameter of hub,

$D_1$  = Nominal or outside diameter of bolt,

$D_1$  = Diameter of bolt circle,

$n$  = Number of bolts,

$t_f$  = Thickness of flange,

$\tau_s$ ,  $\tau_b$  and  $\tau_k$  = Allowable shear stress for shaft, bolt and key material respectively

$\tau_c$  = Allowable shear stress for the flange material i.e. cast iron,

$\sigma_{cb}$ , and  $\sigma_{ck}$  = Allowable crushing stress for bolt and key material respectively.

The flange coupling is designed as discussed below:

#### **1. Design for hub**

The hub is designed by considering it as a hollow shaft, transmitting the same torque ( $T$ ) as that of a solid shaft.

$$T = \frac{\pi}{16} \times \tau_c \left( \frac{D^4 - d^4}{D} \right)$$

The outer diameter of hub is usually taken as twice the diameter of shaft. Therefore from the above relation, the induced shearing stress in the hub may be checked.

The length of hub ( $L$ ) is taken as  $1.5 d$ .

#### **2. Design for key**

The key is designed with usual proportions and then checked for shearing and crushing stresses. The material of key is usually the same as that of shaft. The length of key is taken equal to the length of hub.

#### **3. Design for flange**

The flange at the junction of the hub is under shear while transmitting the torque. Therefore, the torque transmitted,

$$T = \text{Circumference of hub} \times \text{Thickness of flange} \times \text{Shear stress of flange} \times \text{Radius of hub}$$

The thickness of flange is usually taken as half the diameter of shaft. Therefore from the above relation, the induced shearing stress in the flange may be checked.

#### 4. Design for bolts

The bolts are subjected to shear stress due to the torque transmitted. The number of bolts (n) depends upon the diameter of shaft and the pitch circle diameter of bolts ( $D_1$ ) is taken as 3 d. We know that

Load on each bolt

$$= \frac{\pi}{4} (d_1)^2 \tau_b$$

Then, Total load on all the bolts

$$= \frac{\pi}{4} (d_1)^2 \tau_b \times n$$

And torque transmitted,

$$T = \frac{\pi}{4} (d_1)^2 \tau_b \times n \times \frac{D_1}{2}$$

From this equation, the diameter of bolt ( $d_1$ ) may be obtained. Now the diameter of bolt may be checked in crushing.

We know that area resisting crushing of all the bolts =  $n \times d_1 \times t_f$

And crushing strength of all the bolts =  $(n \times d_1 \times t_f) \sigma_{cb}$

Torque,

$$T = (n \times d_1 \times t_f \times \sigma_{cb}) \frac{D_1}{2}$$

From this equation, the induced crushing stress in the bolts may be checked.

#### **References:**

1. Machine Design - V.Bandari .
2. Machine Design – R.S. Khurmi
3. Design Data hand Book - S MD Jalaludin.

Problem: Design a cast iron protective type flange coupling to transmit 15 kW at 900 r.p.m. from an electric motor to a compressor. The service factor may be assumed as 1.35. The following permissible stresses may be used :

Shear stress for shaft, bolt and key material = 40 MPa

Crushing stress for bolt and key = 80 MPa

Shear stress for cast iron = 8 MPa

Draw a neat sketch of the coupling.

Solution. Given:  $P = 15 \text{ kW} = 15 \times 10^3 \text{ W}$ ;  $N = 900 \text{ r.p.m.}$  ; Service factor = 1.35 ;  $\tau_s = \tau_b = \tau_k = 40 \text{ MPa} = 40 \text{ N/mm}^2$  ;  $\sigma_{cb} = \sigma_{ck} = 80 \text{ MPa} = 80 \text{ N/mm}^2$  ;  $\tau_c = 8 \text{ MPa} = 8 \text{ N/mm}^2$ .

The protective type flange coupling is designed as discussed below:

### 1. Design for hub

First of all, let us find the diameter of the shaft (d). We know that the torque transmitted by the shaft,

$$T = \frac{P \times 60}{2 \pi N} = \frac{15 \times 10^3 \times 60}{2 \pi \times 900} = 159.13 \text{ N-m}$$

Since the service factor is 1.35, therefore the maximum torque transmitted by the shaft,  $T_{\max} = 1.35 \times 159.13 = 215 \text{ N-m} = 215 \times 10^3 \text{ N-mm}$

We know that the torque transmitted by the shaft (T),

$$215 \times 10^3 = \frac{\pi}{16} \times \tau_s \times d^3 = \frac{\pi}{16} \times 40 \times d^3 = 7.86 d^3$$

$$d^3 = 215 \times 10^3 / 7.86 = 27.4 \times 10^3 \quad \text{or} \quad d = 30.1 \text{ say } 35 \text{ mm Ans.}$$

We know that outer diameter of the hub,

$$D = 2d = 2 \times 35 = 70 \text{ mm Ans.}$$

And length of hub,  $L = 1.5 d = 1.5 \times 35 = 52.5 \text{ mm Ans.}$

Let us now check the induced shear stress for the hub material which is cast iron. Considering the hub as a hollow shaft. We know that the maximum torque transmitted ( $T_{\max}$ ).

$$215 \times 10^3 = \frac{\pi}{16} \times \tau_c \left[ \frac{D^4 - d^4}{D} \right] = \frac{\pi}{16} \times \tau_c \left[ \frac{(70)^4 - (35)^4}{70} \right] = 63 \, 147 \tau_c$$

$$\text{Then, } \tau_c = 215 \times 10^3 / 63 \, 147 = 3.4 \text{ N/mm}^2 = 3.4 \text{ MPa}$$

Since the induced shear stress for the hub material (i.e. cast iron) is less than the permissible value of 8 MPa, therefore the design of hub is safe.

### 2. Design for key



Since the crushing stress for the key material is twice its shear stress (i.e.  $\sigma_{ck} = 2\tau_k$ ), therefore a square key may be used. From DDB, we find that for a shaft of 35 mm diameter,

Width of key,  $w = 12$  mm Ans.

And thickness of key,  $t = w = 12$  mm Ans.

The length of key ( $l$ ) is taken equal to the length of hub.

Then,  $l = L = 52.5$  mm Ans.

Let us now check the induced stresses in the key by considering it in shearing and crushing.

Considering the key in shearing. We know that the maximum torque transmitted ( $T_{max}$ ),

$$215 \times 10^3 = l \times w \times \tau_k \times \frac{d}{2} = 52.5 \times 12 \times \tau_k \times \frac{35}{2} = 11025 \tau_k$$

Then,  $\tau_k = 215 \times 10^3 / 11025 = 19.5$  N/mm<sup>2</sup> = 19.5 MPa

Considering the key in crushing. We know that the maximum torque transmitted ( $T_{max}$ ),

$$215 \times 10^3 = l \times \frac{t}{2} \times \sigma_{ck} \times \frac{d}{2} = 52.5 \times \frac{12}{2} \times \sigma_{ck} \times \frac{35}{2} = 5512.5 \sigma_{ck}$$

$\sigma_{ck} = 215 \times 10^3 / 5512.5 = 39$  N/mm<sup>2</sup> = 39 MPa.

Since the induced shear and crushing stresses in the key are less than the permissible stresses, therefore the design for key is safe.

### 3. Design for flange

The thickness of flange ( $t_f$ ) is taken as 0.5 d.

Then,  $t_f = 0.5 d = 0.5 \times 35 = 17.5$  mm Ans.

Let us now check the induced shearing stress in the flange by considering the flange at the junction of the hub in shear.

We know that the maximum torque transmitted ( $T_{max}$ ),

$$215 \times 10^3 = \frac{\pi D^2}{2} \times \tau_c \times t_f = \frac{\pi (70)^2}{2} \times \tau_c \times 17.5 = 134713 \tau_c$$

$\tau_c = 215 \times 10^3 / 134713 = 1.6$  N/mm<sup>2</sup> = 1.6 MPa

Since the induced shear stress in the flange is less than 8 MPa, therefore the design of flange is safe.

### 4. Design for bolts

Let  $d_1$  = Nominal diameter of bolts.

Since the diameter of the shaft is 35 mm, therefore let us take the number of bolts,

$n = 3$  and pitch circle diameter of bolts,

$D_1 = 3d = 3 \times 35 = 105$  mm

The bolts are subjected to shear stress due to the torque transmitted. We know that the maximum torque transmitted ( $T_{\max}$ ),

$$215 \times 10^3 = \frac{\pi}{4} (d_1)^2 \tau_b \times n \times \frac{D_1}{2} = \frac{\pi}{4} (d_1)^2 40 \times 3 \times \frac{105}{2} = 4950 (d_1)^2$$

$$(d_1)^2 = 215 \times 103/4950 = 43.43 \text{ or } d_1 = 6.6 \text{ mm}$$

Assuming coarse threads, the nearest standard size of bolt is M 8. Ans.

Other proportions of the flange are taken as follows:

Outer diameter of the flange,

$$D_2 = 4 d = 4 \times 35 = 140 \text{ mm Ans.}$$

Thickness of the protective circumferential flange,

$$t_p = 0.25 d = 0.25 \times 35 = 8.75 \text{ say } 10 \text{ mm Ans.}$$

**References:**

1. Machine Design - V.Bandari .
2. Machine Design – R.S. Khurmi
3. Design Data hand Book - S MD Jalaludin.

### **Flexible Coupling:**

We have already discussed that a flexible coupling is used to join the abutting ends of shafts when they are not in exact alignment. In the case of a direct coupled drive from a prime mover to an electric generator, we should have four bearings at a comparatively close distance. In such a case and in many others, as in a direct electric drive from an electric motor to a machine tool, a flexible coupling is used so as to permit an axial misalignment of the shaft without undue absorption of the power which the shaft are transmitting.

### **Bushed-pin Flexible Coupling**

A bushed-pin flexible coupling, as shown in Fig., is a modification of the rigid type of flange coupling. The coupling bolts are known as pins.

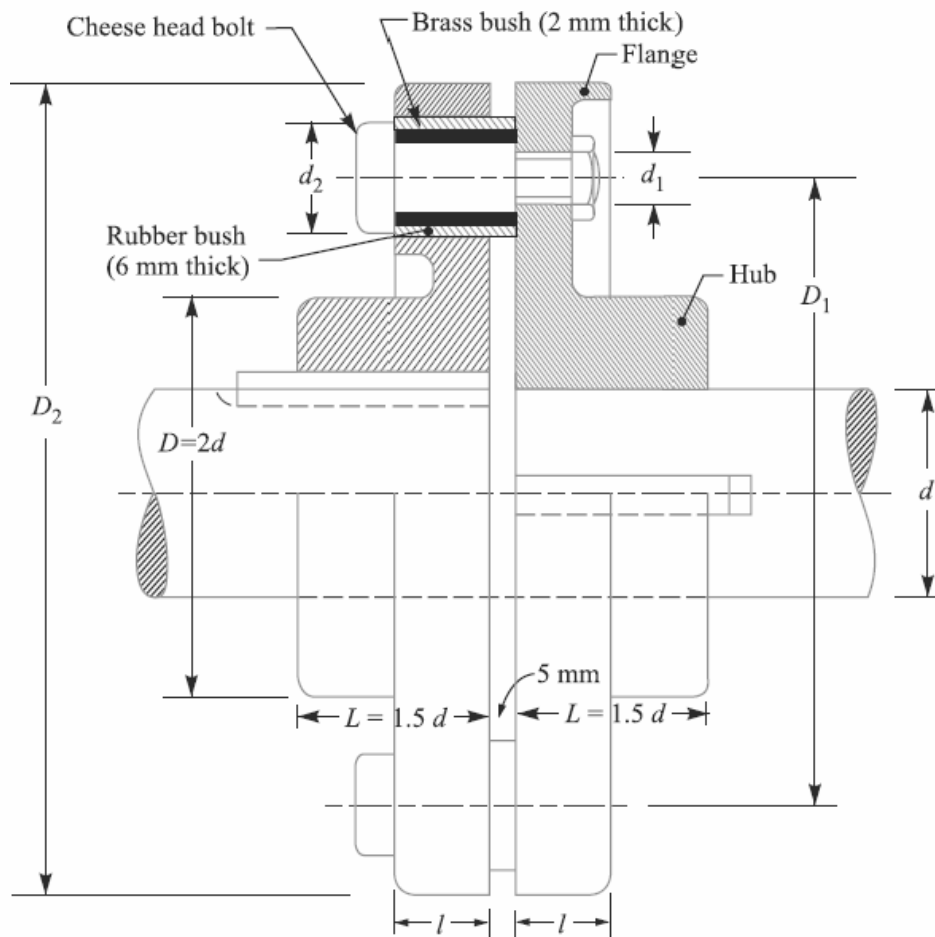

The rubber or leather bushes are used over the pins. The two halves of the coupling are dissimilar in construction. A clearance of 5 mm is left between the face of the two halves of the coupling. There is no rigid connection between them and the drive takes place through the medium of the compressible rubber or leather bushes.

In designing the bushed-pin flexible coupling, the proportions of the rigid type flange coupling are modified. The main modification is to reduce the bearing pressure on the rubber or leather bushes and it should not exceed 0.5 N/mm<sup>2</sup>. In order to keep the low bearing pressure, the pitch circle diameter and the pin size is increased.

Let  $l$  = Length of bush in the flange,  $D_2$

= Diameter of bush,

$P_b$  = Bearing pressure on the bush or pin,

$n$  = Number of pins, and

$D_1$  = Diameter of pitch circle of the pins.

We know that bearing load acting on each pin,

$$W = p_b \times d_2 \times l$$

Then, Total bearing load on the bush or pins

$$= W \times n = p_b \times d_2 \times l \times n$$

And the torque transmitted by the coupling,

$$T = W \times n \left( \frac{D_1}{2} \right) = p_b \times d_2 \times l \times n \left( \frac{D_1}{2} \right)$$

The threaded portion of the pin in the right hand flange should be a tapping fit in the coupling hole to avoid bending stresses.

The threaded length of the pin should be as small as possible so that the direct shear stress can be taken by the unthreaded neck.

Direct shear stress due to pure torsion in the coupling halves,

$$\tau = \frac{W}{\frac{\pi}{4} (d_1)^2}$$

Since the pin and the rubber or leather bush is not rigidly held in the left hand flange, therefore the tangential load ( $W$ ) at the enlarged portion will exert a bending action

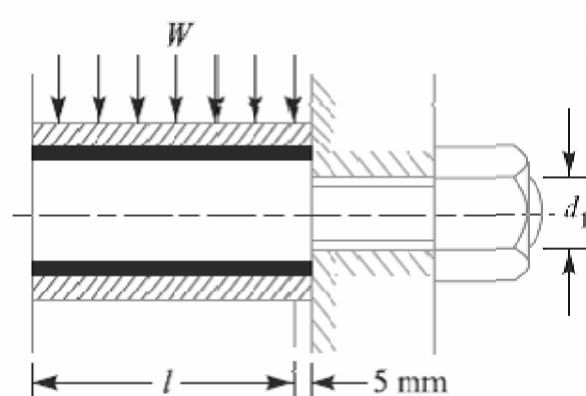

on the pin as shown in Fig. The bush portion of the pin acts as a cantilever beam of length  $l$ . Assuming a uniform distribution of the load  $W$  along the bush, the maximum bending moment on the pin,

$$M = W \left( \frac{l}{2} + 5 \text{ mm} \right)$$

We know that bending stress,

$$\sigma = \frac{M}{Z} = \frac{W \left( \frac{l}{2} + 5 \text{ mm} \right)}{\frac{\pi}{32} (d_1)^3}$$

Since the pin is subjected to bending and shear stresses, therefore the design must be checked either for the maximum principal stress or maximum shear stress by the following relations:

Maximum principal stress

$$= \frac{1}{2} \left[ \sigma + \sqrt{\sigma^2 + 4\tau^2} \right]$$

and the maximum shear stress on the pin

$$= \frac{1}{2} \sqrt{\sigma^2 + 4\tau^2}$$

The value of maximum principal stress varies from 28 to 42 MPa.

**Note:** After designing the pins and rubber bush, the hub, key and flange may be designed in the similar way as discussed for flange coupling.

**References:**

1. Machine Design - V.Bandari .
2. Machine Design – R.S. Khurmi
3. Design Data hand Book - S MD Jalaludin.

Problem:

Design a bushed-pin type of flexible coupling to connect a pump shaft to a motor shaft transmitting 32 kW at 960 r.p.m. The overall torque is 20 percent more than mean torque. The material properties are as follows:

- (a) The allowable shear and crushing stress for shaft and key material is 40 MPa and 80 MPa respectively.
- (b) The allowable shear stress for cast iron is 15 MPa.
- (c) The allowable bearing pressure for rubber bush is 0.8 N/mm<sup>2</sup>.
- (d) The material of the pin is same as that of shaft and key.

Draw neat sketch of the coupling.

**Solution.** Given:  $P = 32 \text{ kW} = 32 \times 10^3 \text{ W}$ ;  $N = 960 \text{ r.p.m.}$ ;  $T_{\max} = 1.2 T_{\text{mean}}$ ;  $\tau_s = \tau_k = 40 \text{ MPa} = 40 \text{ N/mm}^2$ ;  $\sigma_{cs} = \sigma_{ck} = 80 \text{ MPa} = 80 \text{ N/mm}^2$ ;  $\tau_c = 15 \text{ MPa} = 15 \text{ N/mm}^2$ ;  $p_b = 0.8 \text{ N/mm}^2$ .

#### 1. Design for pins and rubber bush

$$T_{\text{mean}} = \frac{P \times 60}{2\pi N} = \frac{32 \times 10^3 \times 60}{2\pi \times 960} = 318.3 \text{ N-m}$$

$$T_{\max} = 1.2 T_{\text{mean}} = 1.2 \times 318.3 = 382 \text{ N-m} = 382 \times 10^3 \text{ N-mm}$$

$$382 \times 10^3 = \frac{\pi}{16} \times \tau_s \times d^3 = \frac{\pi}{16} \times 40 \times d^3 = 7.86 d^3$$

$$d^3 = 382 \times 10^3 / 7.86 = 48.6 \times 10^3 \text{ or } d = 36.5 \text{ say } 40 \text{ mm}$$

$$d_1 = \frac{0.5 d}{\sqrt{n}} = \frac{0.5 \times 40}{\sqrt{6}} = 8.2 \text{ mm}$$

In order to allow for the bending stress induced due to the compressibility of the rubber bush, the diameter of the pin ( $d_1$ ) may be taken as 20 mm. Ans.

The length of the pin of least diameter i.e.  $d_1 = 20 \text{ mm}$  is threaded and secured in the right hand coupling half by a standard nut and washer. The enlarged portion of the pin which is in the left hand coupling half is made of 24 mm diameter. On the enlarged portion, a brass bush of thickness 2 mm is pressed. A brass bush carries a rubber bush. Assume the thickness of rubber bush as 6 mm.

So, Overall diameter of rubber bush,

$$d_2 = 24 + 2 \times 2 + 2 \times 6 = 40 \text{ mm} \quad \text{Ans.}$$

and diameter of the pitch circle of the pins,

$$D_1 = 2 d + d_2 + 2 \times 6 = 2 \times 40 + 40 + 12 = 132 \text{ mm} \quad \text{Ans.}$$

Let  $l$  = Length of the bush in the flange.

We know that the bearing load acting on each pin,

$$W = p_b \times d_2 \times l = 0.8 \times 40 \times l = 32l \text{ N}$$

And the maximum torque transmitted by the coupling ( $T_{\max}$ ),

$$382 \times 10^3 = W \times n \times \frac{D_1}{2} = 32l \times 6 \times \frac{132}{2} = 12672l$$

$$l = 382 \times 10^3 / 12672 = 30.1 \text{ say } 32 \text{ mm}$$

And  $W = 32l = 32 \times 32 = 1024 \text{ N}$

So, Direct stress due to pure torsion in the coupling halves,

$$\tau = \frac{W}{\frac{\pi}{4}(d_1)^2} = \frac{1024}{\frac{\pi}{4}(20)^2} = 3.26 \text{ N/mm}^2$$

Since the pin and the rubber bush are not rigidly held in the left hand flange, therefore the tangential load ( $W$ ) at the enlarged portion will exert a bending action on the pin. Assuming a uniform distribution of load ( $W$ ) along the bush, the maximum bending moment on the pin,

$$M = W \left( \frac{l}{2} + 5 \right) = 1024 \left( \frac{32}{2} + 5 \right) = 21504 \text{ N-mm}$$

$$Z = \frac{\pi}{32}(d_1)^3 = \frac{\pi}{32}(20)^3 = 785.5 \text{ mm}^3$$

$$\sigma = \frac{M}{Z} = \frac{21504}{785.5} = 27.4 \text{ N/mm}^2$$

Maximum principal stress

$$\begin{aligned} &= \frac{1}{2} \left[ \sigma + \sqrt{\sigma^2 + 4\tau^2} \right] = \frac{1}{2} \left[ 27.4 + \sqrt{(27.4)^2 + 4(3.26)^2} \right] \\ &= 13.7 + 14.1 = 27.8 \text{ N/mm}^2 \end{aligned}$$

And maximum shear stress

$$= \frac{1}{2} \left[ \sqrt{\sigma^2 + 4\tau^2} \right] = \frac{1}{2} \left[ \sqrt{(27.4)^2 + 4(3.26)^2} \right] = 14.1 \text{ N/mm}^2$$

Since the maximum principal stress and maximum shear stress are within limits, therefore the design is safe.

## 2. Design for hub

We know that the outer diameter of the hub,





We know that the maximum torque transmitted ( $T_{\max}$ ),

$$382 \times 10^3 = \frac{\pi D^2}{2} \times \tau_c \times t_f = \frac{\pi(80)^2}{2} \times \tau_c \times 20 = 201 \times 10^3 \tau_c$$

$$\tau_c = 382 \times 10^3 / 201 \times 10^3 = 1.9 \text{ N/mm}^2 = 1.9 \text{ MPa}$$

Since the induced shear stress in the flange of cast iron is less than 15 MPa, therefore the design of flange is safe.

**References:**

1. Machine Design - V.Bandari .
2. Machine Design – R.S. Khurmi
3. Design Data hand Book - S MD Jalaludin.

Problem:

Design a cast iron protective type flange coupling to transmit 15 kW at 900 r.p.m. from an electric motor to a compressor. The service factor may be assumed as 1.35. The following permissible stresses may be used:

Shear stress for shaft, bolt and key material = 40 MPa

Crushing stress for bolt and key = 80 MPa

Shear stress for cast iron = 8 MPa

Draw a neat sketch of the coupling.

**Solution.** Given:  $P = 15 \text{ kW} = 15 \times 10^3 \text{ W}$ ;  $N = 900 \text{ r.p.m.}$ ; Service factor = 1.35;  $\tau_s = \tau_b = \tau_k = 40 \text{ MPa} = 40 \text{ N/mm}^2$ ;  $\sigma_{cb} = \sigma_{ck} = 80 \text{ MPa} = 80 \text{ N/mm}^2$ ;  $\tau_c = 8 \text{ MPa} = 8 \text{ N/mm}^2$ .

The protective type flange coupling is designed as discussed below:

### 1. Design for hub

First of all, let us find the diameter of the shaft ( $d$ ). We know that the torque transmitted by the shaft,

$$T = \frac{P \times 60}{2 \pi N} = \frac{15 \times 10^3 \times 60}{2 \pi \times 900} = 159.13 \text{ N-m}$$

Since the service factor is 1.35, therefore the maximum torque transmitted by the shaft,  $T_{\max} = 1.35 \times 159.13 = 215 \text{ N-m} = 215 \times 10^3 \text{ N-mm}$

We know that the torque transmitted by the shaft ( $T$ ),

$$215 \times 10^3 = \frac{\pi}{16} \times \tau_s \times d^3 = \frac{\pi}{16} \times 40 \times d^3 = 7.86 d^3$$
$$d^3 = 215 \times 10^3 / 7.86 = 27.4 \times 10^3 \quad \text{or} \quad d = 30.1 \text{ say } 35 \text{ mm Ans.}$$

We know that outer diameter of the hub,

$$D = 2d = 2 \times 35 = 70 \text{ mm Ans.}$$

And length of hub,  $L = 1.5 d = 1.5 \times 35 = 52.5 \text{ mm Ans.}$

Let us now check the induced shear stress for the hub material which is cast iron. Considering the hub as a hollow shaft. We know that the maximum torque transmitted ( $T_{\max}$ ).

$$215 \times 10^3 = \frac{\pi}{16} \times \tau_c \left[ \frac{D^4 - d^4}{D} \right] = \frac{\pi}{16} \times \tau_c \left[ \frac{(70)^4 - (35)^4}{70} \right] = 63\,147 \tau_c$$

$$\text{Then, } \tau_c = 215 \times 10^3 / 63\,147 = 3.4 \text{ N/mm}^2 = 3.4 \text{ MPa}$$

Since the induced shear stress for the hub material (i.e. cast iron) is less than the permissible value of 8 MPa, therefore the design of hub is safe.

## 2. Design for key

Since the crushing stress for the key material is twice its shear stress (i.e.  $\sigma_{ck} = 2\tau_k$ ), therefore a square key may be used. From DDB, we find that for a shaft of 35 mm diameter,

Width of key,  $w = 12$  mm Ans.

And thickness of key,  $t = w = 12$  mm Ans.

The length of key ( $l$ ) is taken equal to the length of hub.

Then,  $l = L = 52.5$  mm Ans.

Let us now check the induced stresses in the key by considering it in shearing and crushing.

Considering the key in shearing. We know that the maximum torque transmitted ( $T_{max}$ ),

$$215 \times 10^3 = l \times w \times \tau_k \times \frac{d}{2} = 52.5 \times 12 \times \tau_k \times \frac{35}{2} = 11\,025 \tau_k$$

Then,  $\tau_k = 215 \times 10^3 / 11\,025 = 19.5$  N/mm<sup>2</sup> = 19.5 MPa

Considering the key in crushing. We know that the maximum torque transmitted ( $T_{max}$ ),

$$215 \times 10^3 = l \times \frac{t}{2} \times \sigma_{ck} \times \frac{d}{2} = 52.5 \times \frac{12}{2} \times \sigma_{ck} \times \frac{35}{2} = 5512.5 \sigma_{ck}$$

$\sigma_{ck} = 215 \times 10^3 / 5512.5 = 39$  N/mm<sup>2</sup> = 39 MPa.

Since the induced shear and crushing stresses in the key are less than the permissible stresses, therefore the design for key is safe.

## 3. Design for flange

The thickness of flange ( $t_f$ ) is taken as 0.5 d.

Then,  $t_f = 0.5 d = 0.5 \times 35 = 17.5$  mm Ans.

Let us now check the induced shearing stress in the flange by considering the flange at the junction of the hub in shear.

We know that the maximum torque transmitted ( $T_{max}$ ),

$$215 \times 10^3 = \frac{\pi D^2}{2} \times \tau_c \times t_f = \frac{\pi (70)^2}{2} \times \tau_c \times 17.5 = 134\,713 \tau_c$$

$\tau_c = 215 \times 10^3 / 134\,713 = 1.6$  N/mm<sup>2</sup> = 1.6 MPa

Since the induced shear stress in the flange is less than 8 MPa, therefore the design of flange is safe.

## 4. Design for bolts

Let  $d_1$  = Nominal diameter of bolts.

Since the diameter of the shaft is 35 mm, therefore let us take the number of bolts,

$n = 3$  and pitch circle diameter of bolts,

$$D_1 = 3d = 3 \times 35 = 105 \text{ mm}$$

The bolts are subjected to shear stress due to the torque transmitted. We know that the maximum torque transmitted ( $T_{\max}$ ),

$$215 \times 10^3 = \frac{\pi}{4} (d_1)^2 \tau_b \times n \times \frac{D_1}{2} = \frac{\pi}{4} (d_1)^2 40 \times 3 \times \frac{105}{2} = 4950 (d_1)^2$$
$$(d_1)^2 = 215 \times 10^3 / 4950 = 43.43 \text{ or } d_1 = 6.6 \text{ mm}$$

Assuming coarse threads, the nearest standard size of bolt is M 8. Ans.

Other proportions of the flange are taken as follows:

Outer diameter of the flange,

$$D_2 = 4d = 4 \times 35 = 140 \text{ mm} \quad \text{Ans.}$$

Thickness of the protective circumferential flange,

$$t_p = 0.25d = 0.25 \times 35 = 8.75 \text{ say } 10 \text{ mm} \quad \text{Ans.}$$

### **References:**

1. Machine Design - V. Bandari .
2. Machine Design – R.S. Khurmi
3. Design Data hand Book - S MD Jalaludin.

Problem:

Two 35 mm shafts are connected by a flanged coupling. The flanges are fitted with 6 bolts on 125 mm bolt circle. The shafts transmit a torque of 800 N-m at 350 r.p.m. For the safe stresses mentioned below, calculate 1. Diameter of bolts; 2. Thickness of flanges; 3. Key dimensions ; 4. Hub length; and 5. Power transmitted. Safe shear stress for shaft material = 63 MPa Safe stress for bolt material = 56 MPa Safe stress for cast iron coupling = 10 MPa Safe stress for key material = 46 MPa

**Solution.** Given:  $d = 35$  mm;  $n = 6$ ;  $D_1 = 125$  mm;  $T = 800$  N-m =  $800 \times 10^3$  N-mm;  $N = 350$  r.p.m.;  $\tau_s = 63$  MPa =  $63$  N/mm<sup>2</sup>;  $\tau_b = 56$  MPa =  $56$  N/mm<sup>2</sup> ;  $\tau_c = 10$  MPa =  $10$  N/mm<sup>2</sup> ;  $\tau_k = 46$  MPa =  $46$  N/mm<sup>2</sup>.

### 1. Diameter of bolts

Let  $d_1$  = Nominal or outside diameter of bolt. We know that the torque transmitted ( T ),

$$800 \times 10^3 = \frac{\pi}{4} (d_1)^2 \tau_b \times n \times \frac{D_1}{2} = \frac{\pi}{4} (d_1)^2 56 \times 6 \times \frac{125}{2} = 16\,495 (d_1)^2$$
$$(d_1)^2 = 800 \times 10^3 / 16\,495 = 48.5 \text{ or } d_1 = 6.96 \text{ say } 8 \text{ mm} \quad \text{Ans.}$$

### 2. Thickness of flanges

Let  $t_f$  = Thickness of flanges.

We know that the torque transmitted (T),

$$800 \times 10^3 = \frac{\pi D^2}{2} \times \tau_c \times t_f = \frac{\pi (2 \times 35)^2}{2} \times 10 \times t_f = 76\,980 t_f \quad \dots (\because D = 2d)$$
$$t_f = 800 \times 10^3 / 76\,980 = 10.4 \text{ say } 12 \text{ mm} \quad \text{Ans.}$$

### 3. Key dimensions

From Table 13.1, we find that the proportions of key for a 35 mm diameter shaft are:

Width of key,  $w = 12$  mm **Ans.**

And thickness of key,  $t = 8$  mm **Ans.**

The length of key (l) is taken equal to the length of hub (L).

$$l = L = 1.5 d = 1.5 \times 35 = 52.5 \text{ mm}$$

Let us now check the induced shear stress in the key. We know that the torque transmitted (T),

$$800 \times 10^3 = l \times w \times \tau_k \times \frac{d}{2} \times = 52.5 \times 12 \times \tau_k \times \frac{35}{2} = 11\,025 \tau_k$$

$$\tau_k = 800 \times 10^3 / 11\,025 = 72.5 \text{ N/mm}^2$$

Since the induced shear stress in the key is more than the given safe stress (46 MPa), therefore let us find the length of key by substituting the value of  $\tau_k = 46 \text{ MPa}$  in the above equation, i.e.

$$800 \times 10^3 = l \times 12 \times 46 \times \frac{35}{2} = 9660 l$$

$$l = 800 \times 10^3 / 9660 = 82.8 \text{ say } 85 \text{ mm Ans.}$$

#### 4. Hub length

Since the length of key is taken equal to the length of hub, therefore we shall take hub length,

$$L = l = 85 \text{ mm Ans.}$$

#### 5. Power transmitted

We know that the power transmitted,

$$P = \frac{T \times 2\pi N}{60} = \frac{800 \times 2\pi \times 350}{60} = 29\,325 \text{ W} = 29.325 \text{ kW Ans.}$$

Problem:

The shaft and the flange of a marine engine are to be designed for flange coupling, in which the flange is forged on the end of the shaft. The following particulars are to be considered in the design:

Power of the engine = 3 MW

Speed of the engine = 100 r.p.m.

Permissible shear stress in bolts and shaft = 60 MPa

Number of bolts used = 8

Pitch circle diameter of bolts = 1.6 × Diameter of shaft

Find: 1. diameter of shaft; 2. diameter of bolts; 3. thickness of flange; and 4. diameter of flange.

**Solution.** Given:  $P = 3 \text{ MW} = 3 \times 10^6 \text{ W}$ ;  $N = 100 \text{ r.p.m.}$ ;  $\tau_b = \tau_s = 60 \text{ MPa} = 60 \text{ N/mm}^2$ ;  $n = 8$ ;  $D_1 = 1.6 d$

#### 1. Diameter of shaft

Let  $d = \text{Diameter of shaft.}$

We know that the torque transmitted by the shaft,

$$T = \frac{P \times 60}{2 \pi N} = \frac{3 \times 10^6 \times 60}{2 \pi \times 100} = 286 \times 10^3 \text{ N-m} = 286 \times 10^6 \text{ N-mm}$$

We also know that torque transmitted by the shaft (T),

$$286 \times 10^6 = \frac{\pi}{16} \times \tau_s \times d^3 = \frac{\pi}{16} \times 60 \times d^3 = 11.78 d^3$$

$$d_3 = 286 \times 10^6 / 11.78 = 24.3 \times 10^6$$

$$\text{or } d = 2.89 \times 10^2 = 289 \text{ say } 300 \text{ mm Ans.}$$

## 2. Diameter of bolts

Let  $d_1$  = Nominal diameter of bolts.

The bolts are subjected to shear stress due to the torque transmitted. We know that torque transmitted (T),

$$286 \times 10^6 = \frac{\pi}{4} (d_1)^2 \tau_b \times n \times \frac{D_1}{2} = \frac{\pi}{4} \times (d_1)^2 \times 60 \times 8 \times \frac{1.6 \times 300}{2}$$

$$= 90\,490 (d_1)^2 \dots (\text{Since } D_1 = 1.6 d)$$

$$\text{So, } (d_1)^2 = 286 \times 10^6 / 90\,490 = 3160 \text{ or } d_1 = 56.2 \text{ mm}$$

Assuming coarse threads, the standard diameter of the bolt is 60 mm (M 60). The taper on the bolt may be taken from 1 in 20 to 1 in 40. **Ans.**

## 3. Thickness of flange

The thickness of flange ( $t_f$ ) is taken as  $d / 3$ .

$$\text{So, } t_f = d / 3 = 300 / 3 = 100 \text{ mm Ans.}$$

Let us now check the induced shear stress in the flange by considering the flange at the junction of the shaft in shear. We know that the torque transmitted (T),

$$286 \times 10^6 = \frac{\pi d^2}{2} \times \tau_s \times t_f = \frac{\pi (300)^2}{2} \times \tau_s \times 100 = 14.14 \times 10^6 \tau_s$$

$$\tau_s = 286 \times 10^6 / 14.14 \times 10^6 = 20.2 \text{ N/mm}^2 = 20.2 \text{ MPa}$$

Since the induced shear stress in the \*flange is less than the permissible shear stress of 60 MPa, therefore the thickness of flange ( $t_f = 100$  mm) is safe.

## 4. Diameter of flange

The diameter of flange ( $D_2$ ) is taken as 2.2 d.

$$\text{So, } D_2 = 2.2 d = 2.2 \times 300 = 660 \text{ mm Ans.}$$

## References:

1. Machine Design - V.Bandari .

2. Machine Design – R.S. Khurmi
3. Design Data hand Book - S MD Jalaludin.



# UNIT V

## Bearings

### 1.1 BEARINGS

A bearing is machine part, which support a moving element and confines its motion. The supporting member is usually designated as bearing and the supporting member may be journal. Since there is a relative motion between the bearing and the moving element, a certain amount of power must be absorbed in overcoming friction, and if the surface actually touches, there will be a rapid wear.

**Classification:** Bearings are classified as follows:

1. **Depending upon the nature of contact between the working surfaces:-**

- a) Sliding contact bearings
- b) Rolling contact bearings.

**a) SLIDING BEARINGS:**

- Hydrodynamically lubricated bearings
- Bearings with boundary lubrication
- Bearings with Extreme boundary lubrication.
- Bearings with Hydrostatic lubrication.

**b) ROLLING ELEMENT BEARINGS:**

- Ball bearings
- Roller bearings
- Needle roller bearings

1. **Based on the nature of the load supported:**

- Radial bearings - Journal bearings
- Thrust bearings
  - Plane thrust bearings
  - Thrust bearings with fixed shoes
  - Thrust bearings with Pivoted shoes
- Bearings for combined Axial and Radial loads.

**JOURNAL BEARING:**

It is one, which forms the sleeve around the shaft and supports a bearing at right angles to the axis of the bearing. The portion of the shaft resting on the sleeve is called the journal. **Example of journal bearings are-** Solid bearing , Bushed bearing and Pedestal bearing.

**Solid bearing:**

A cylindrical hole formed in a cast iron machine member to receive the shaft which makes a running fit is the simplest type of solid journal bearing. Its rectangular base plate has two holes drilled in it for bolting down the bearing in its position as shown in the figure 1.1. An oil hole is provided at the top to lubricate the bearing. There is no means of adjustment for wear and the shaft must be introduced into the bearing endwise. It is therefore used for shafts, which carry light loads and rotate at moderate speeds.

**Bushed bearing:**

It consists of mainly two parts, the cast iron block and bush; the bush is made of soft material such as brass, bronze or gunmetal. The bush is pressed inside the bore in the cast iron block and is prevented from rotating or sliding by means of grub- screw as shown in the figure 1.2. When the bush gets worn out it can be easily replaced. Elongated holes in the base are provided for lateral adjustment.

**Pedestal bearing:**

It is also called Plummer block. Figure 1.3 shows half sectional front view of the Plummer block. It consists of cast iron pedestal, phosphor bronze bushes or steps made in two

halves and cast iron cap. A cap by means of two square headed bolts holds the halves of the steps together. The steps are provided with collars on either side in order to prevent its axial movement. The snug in the bottom step, which fits into the corresponding hole in the body, prevents the rotation of the steps along with the shaft. This type of bearing can be placed any where along the shaft length.

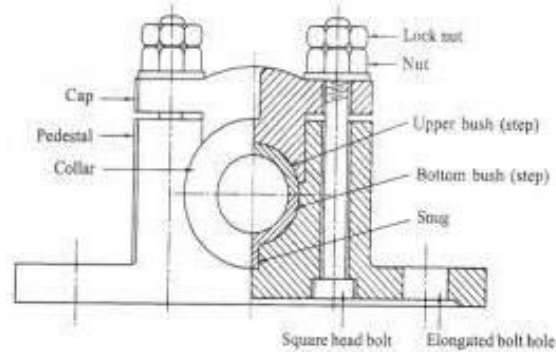

### **Thrust bearing:**

It is used to guide or support the shaft, which is subjected to a load along the axis of the shaft. Since a thrust bearing operates without a clearance between the conjugate parts, an adequate supply of oil to the rubbing surfaces is extremely important. Bearings designed to carry heavy thrust loads may be broadly classified in to two groups-

### **FOOT STEP BEARING, AND COLLAR BEARING**

**Footstep bearing:** Footstep bearings are used to support the lower end of the vertical shafts. A simple form of such bearing is shown in fig 1.4. It consists of cast iron block into which a gunmetal bush is fitted. The bush is prevented from rotating by the snug provided at its neck. The shaft rests on a concave hardened steel disc. This disc is prevented from rotating along with the shaft by means of pin provided at the bottom.

### **Rolling contact bearings:**

The bearings in which the rolling elements are included are referred to as rolling contact bearings. Since the rolling friction is very less compared to the sliding friction, such bearings are known as anti friction bearings.

### **Ball bearings:**

It consists of an inner ring which is mounted on the shaft and an outer ring which is carried by the housing. The inner ring is grooved on the outer surface called inner race and the outer ring is grooved on its inner surface called outer race. In between the inner and outer race there are number of steel balls. A cage pressed steel completes the assembly and provides the means of equally spacing and holding the balls in place as shown in the figure 1.7. Radial ball bearings are used to carry mainly radial loads, but they can also carry axial loads.

### **Cylindrical roller bearings**

The simplest form of a cylindrical roller bearing is shown in fig 1.8. It consists of an inner race, an outer race, and set of roller with a retainer. Due to the line contact between the roller and the raceways, the roller bearing can carry heavy radial loads.

### **Tapered roller bearings:**

In tapered roller bearings shown in the fig. 1.9, the rollers and the races are all truncated cones having a common apex on the shaft centre to assure true rolling contact. The tapered roller bearing can carry heavy radial and axial loads. Such bearings are mounted in pairs so that the two bearings are opposing

each other's thrust.

### **1.1.2 ADVANTAGES OF SLIDING CONTACT BEARINGS:**

- They can be operated at high speeds.
- They can carry heavy radial loads.
- They have the ability to withstand shock and vibration loads.
- Noiseless operation.

#### **Disadvantages:**

- High friction losses during starting.
- More length of the bearing.
- Excessive consumption of the lubricant and high maintenance.

### **1.1.3 ADVANTAGES ROLLING CONTACT BEARINGS:**

- Low starting and less running friction.
- It can carry both radial as well as thrust loads.
- Momentary over loads can be carried without failure.
- Shaft alignment is more accurate than in the sliding bearings.

#### **Disadvantages:**

More noisy at high speeds. Low resistance to shock loads. High initial cost.

Finite life due to eventual failure by fatigue

## 1.2 SOLID FRICTION

1. Resistance force for sliding
  - Static coefficient of friction
  - Kinetic coefficient of friction
2. Causes
  - Surface roughness (asperities)
  - Adhesion (bonding between dissimilar materials)
3. Factors influencing friction
  - Sliding friction depends on the normal force and frictional coefficient, independent of the sliding speed and contact area
4. Effect of Friction
  - Frictional heat (burns out the bearings)
  - Wear (loss of material due to cutting action of opposing motion)
5. Engineers control friction
  - Increase friction when needed (using rougher surfaces)
  - Reduce friction when not needed (lubrication)

The coefficients of friction for different material combinations under different conditions

### 1.3 LUBRICATION:

Prevention of metal to metal contact by means of an intervening layer of fluid or fluid like material.

#### Types of sliding lubrication:

- Sliding with Fluid film lubrication.
- Sliding with Boundary lubrication.
- Sliding with Extreme boundary lubrication.
- Sliding with clean surfaces.

#### 1.3.1 HYDRODYNAMIC / THICK FILM LUBRICATION / FLUID FILM LUBRICATION

Metal to Metal contact is prevented. This is shown in figure 1.10. Friction in the bearing is due to oil film friction only. Viscosity of the lubricant plays a vital role in the power loss, temperature rise & flow through of the lubricant through the bearing. The principle operation is the Hydrodynamic theory. This lubrication can exist under moderately loaded bearings running at sufficiently high speeds

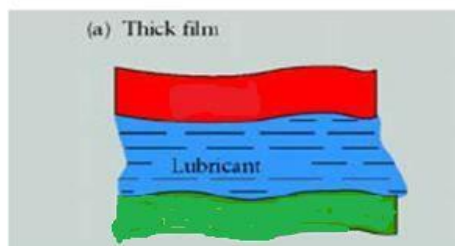

### 1.1.1 BOUDARY LUBRICATION (THIN FILM LUBRICATION)

During starting and stopping, when the velocity is too low, the oil film is not capable of supporting the load. There will be metal to metal contact at some spots as shown in figure 1.11. Boundary lubrication exists also in a bearing if the load becomes too high or if the viscosity of the lubricant is too low. Mechanical and chemical properties of the bearing surfaces and the lubricants play a vital role.

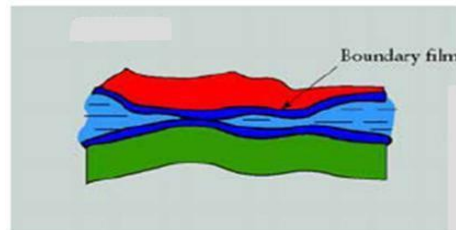

Oiliness of lubricant becomes an important property in boundary lubrication. Anti oxidants and Anti-corrosives are added to lubricants to improve their performance. Additives are added to improve the viscosity index of the lubricants.

#### Oiliness Agents

- Increase the oil film's resistance to rupture, usually made from oils of animals or vegetables.
- The molecules of these oiliness agents have strong affinity for petroleum oil and for metal surfaces that are not easily dislodged.
- Oiliness and lubricity (another term for oiliness), not related to viscosity, manifest itself under boundary lubrication; reduce friction by preventing the oil film breakdown.

#### Anti-Wear Agents

Mild EP additives protect against wear under moderate loads for boundary lubrications Anti-wear agents react chemically with the metal to form a protective coating that reduces friction, also called as anti-scuff additives.

### 1.3.2 Extreme boundary lubrication

Under certain conditions of temperature and load, the boundary film breaks leading to direct metal to metal contact as shown in figure 1.12. Seizure of the metallic surfaces and destruction of one or both surfaces begins. Strong intermolecular forces at the point of contact results in tearing of metallic particles. "Plowing" of softer surfaces by surface irregularities of the harder surfaces. Bearing material properties become significant. Proper bearing materials should be selected.

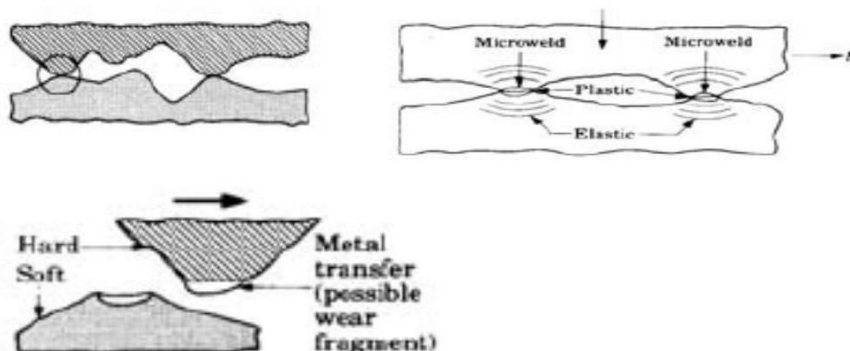

Fig.1.12 Extreme Boundary Lubrication

### **Extreme-Pressure Agents**

Scoring and pitting of metal surfaces might occur as a result of this case, seizure is the primary concern. Additives are derivatives of sulphur, phosphorous, or chlorine. These additives prevent the welding of mating surfaces under extreme loads and temperatures.

### **Stick-Slip Lubrication**

A special case of boundary lubrication when a slow or reciprocating action exists. This action is destructive to the full fluid film. Additives are added to prevent this phenomenon causing more drag force when the part is in motion relative to static friction. This prevents jumping ahead phenomenon.

### **1.3.3 Solid film lubrication**

When bearings must be operated at extreme temperatures, a solid film lubricant such as graphite or molybdenum di-sulphide must be used because the ordinary mineral oils are not satisfactory at elevated temperatures. Much research is currently being carried out in an effort to find composite bearing materials with low wear rates as well as small frictional coefficients.

### **1.4.5. Hydrostatic lubrication**

*Hydrostatic lubrication* is obtained by introducing the lubricant, which is sometimes air or water, into the load-bearing area at a pressure high enough to separate the surfaces with a relatively thick film of lubricant. So, unlike hydrodynamic lubrication, this kind of lubrication does not require motion of one surface relative to another. Useful in designing bearings where the velocities are small or zero and where the frictional resistance is to be an absolute minimum.

### **1.4.6 Elasto Hydrodynamic lubrication**

*Elasto-hydrodynamic lubrication* is the phenomenon that occurs when a lubricant is introduced between surfaces that are in rolling contact, such as mating gears or rolling bearings. The mathematical explanation requires the Hertzian theory of contact stress and fluid mechanics.

## **1.4 Newton's Law of Viscous Flow**

In Fig. 1.13 let a plate  $A$  be moving with a velocity  $U$  on a film of lubricant of thickness  $h$ . Imagine the film to be composed of a series of horizontal layers and the force  $F$  causing these layers to deform or slide on one another just like a deck of cards. The layers in contact with the moving plate are assumed to have a velocity  $U$ ; those in contact with the stationary surface are assumed to have a zero velocity. Intermediate layers have velocities that depend upon their distances  $y$  from the stationary surface.

Newton's viscous effect states that the shear stress in the fluid is proportional to the rate of change of velocity with respect to  $y$ .

Thus

$$T = F/A = Z$$

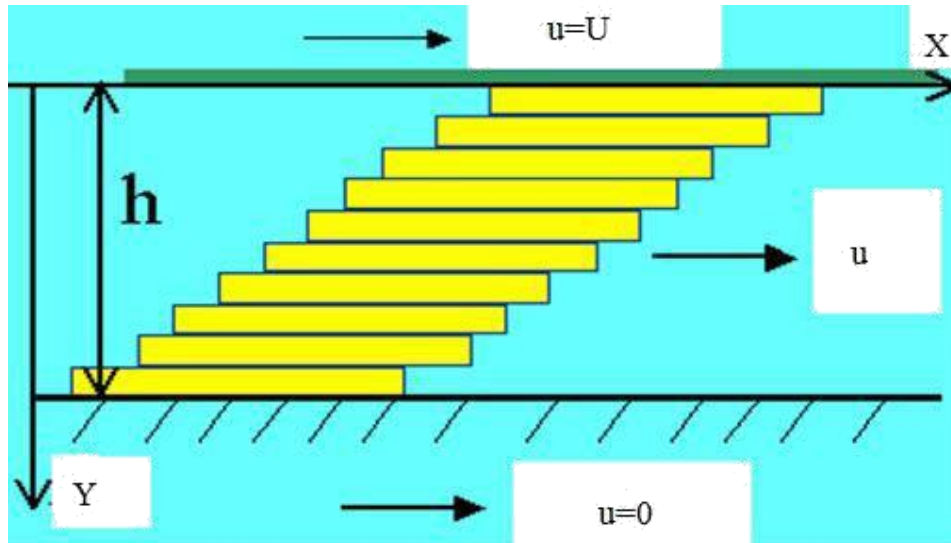

where  $Z$  is the constant of proportionality and defines *absolute viscosity*, also called *dynamic viscosity*. The derivative  $du/dy$  is the rate of change of velocity with distance and may be called the rate of shear, or the velocity gradient. The viscosity  $Z$  is thus a measure of the internal frictional resistance of the fluid.

For most lubricating fluids, the rate of shear is constant, and  $du/dy = U/h$ . Fluids exhibiting this characteristic are known as a Newtonian fluids.

$$\text{Therefore } \tau = F/A = Z (U/h).$$

The absolute viscosity is measured by the pascal-second ( $\text{Pa} \cdot \text{s}$ ) in SI; this is the same as a Newton-second per square meter.

The poise is the cgs unit of dynamic or absolute viscosity, and its unit is the dyne second per square centimeter ( $\text{dyn} \cdot \text{s}/\text{cm}^2$ ). It has been customary to use the centipoises (cP) in analysis, because its value is more convenient. The conversion from cgs units to SI units is as follows:

$$\mathbf{Z (\text{Pa} \cdot \text{s}) = (10)^{-3} Z (\text{cP})}$$

Kinematic Viscosity is the ratio of the absolute Viscosity to the density of the lubricant.

$$\mathbf{Z_k = Z / \rho}$$

The ASTM standard method for determining viscosity uses an instrument called the Saybolt Universal Viscosimeter. The method consists of measuring the time in seconds for 60 mL of lubricant at a specified temperature to run through a tube 17.6 micron in diameter and 12.25 mm long. The result is called the *kinematic viscosity*, and in the past



the unit of the square centimeter per second has been used. One square centimetre per second is defined as a **stoke**.

The kinematic viscosity based upon seconds Saybolt, also called *Saybolt Universal viscosity* (SUV) in seconds, is given by:

$$\mathbf{Z_k = (0.22t - 180/t)}$$

where  $Z_k$  is in centistokes (cSt) and  $t$  is the number of seconds Saybolt.

### 1.5 Viscosity -Temperature relation

Viscous resistance of lubricating oil is due to intermolecular forces. As the temperature increases, the oil expands and the molecules move further apart decreasing the intermolecular forces. Therefore the viscosity of the lubricating oil decreases with temperature as shown in the figure.1.14. If speed increases, the oil's temperature increases and viscosity drops, thus making it better suited for the new condition. An oil with high viscosity creates higher temperature and this in turn reduces viscosity. This, however, generates an equilibrium condition that is not optimum. Thus, selection of the correct viscosity oil for the bearings is essential.

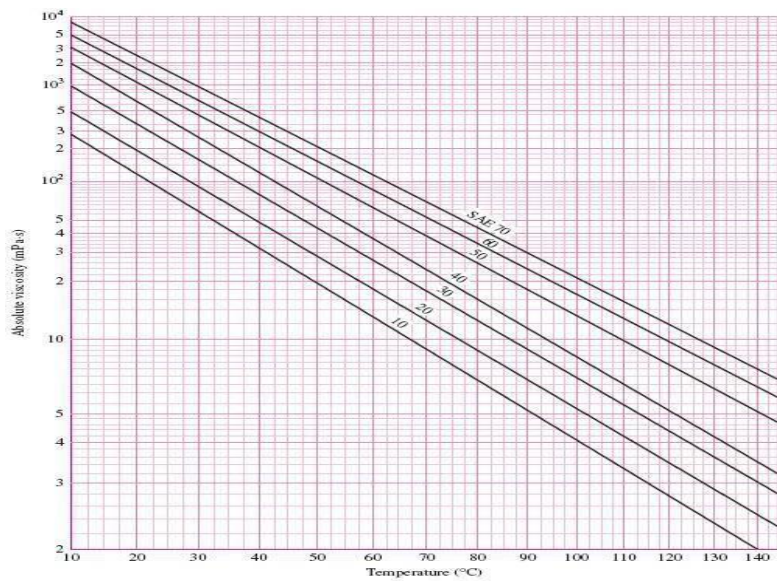

### Viscosity index of a lubricating oil

Viscosity Index (V.I) is value representing the degree for which the oil viscosity changes with temperature. If this variation is small with temperature, the oil is said to have a high viscosity index. The oil is compared with two standard oils, one having a V.I. of 100 and the other Zero. A viscosity Index of 90 indicates that the oil with this value thins out less rapidly than an oil with V.I. of 50.

## 1.6 Types of lubricants

- Vegetable or Animal oils like Castor oil, Rapeseed oil, palm oil, Olive oil etc.
- Animal oils like lard oil, tallow oil, whale oil, etc.
- Mineral oils-petroleum based- Paraffinic and Naphthenic based oils

### Properties of lubricants

- Availability in wide range of viscosities.
- High Viscosity index.
- Should be Chemically stable with bearing material at all temperatures encountered.
- Oil should have sufficient specific heat to carry away heat without abnormal rise in temperature.
- Reasonable cost.

### Selection Guide for Lubricants

The viscosity of lubricating oil is decisively for the right thickness of the lubricating film (approx. 3-30 $\mu$ m) under consideration of the type of lubricant supply

Low sliding speed	High Viscosity
High sliding speed	Low viscosity
High bearing clearance	High Viscosity
High load ( Bearing pressures)	Higher Viscosity

## 1.7 Bearing materials

Relative **softness** (to absorb foreign particles), reasonable strength, **machinability** (to maintain tolerances), **lubricity**, **temperature and corrosion resistance**, and in some cases, **porosity** (to absorb lubricant) are some of the important properties for a bearing material.

A bearing element should be *less than one-third as hard* as the material running against it in order to provide **embedability** of abrasive particles.

A bearing material should have high compression strength to withstand high pressures without distortion and should have good fatigue strength to avoid failure due to pitting. e.g. in Connecting rod bearings, Crank shaft bearings, etc. A bearing material should have conformability. Soft bearing material has *conformability*. Slight misalignments of bearings can be self-correcting if plastic flow occurs easily in the bearing metal. Clearly there is a compromise between load-bearing ability and conformability.

In bearings operating at high temperatures, possibility of oxidation of lubricating oils leading to formation of corrosive acids is there. The bearing material should be **corrosion resistant**. Bearing material should have easy **availability and low cost**. The bearing material

should be soft to allow the dirt particles to get embedded in the bearing lining and avoid further trouble. This property is known as **Embeddability**.

### Different Bearing Materials

- **Babbitt or White metal** -- usually used as a lining of about 0.5mm thick bonded to bronze, steel or cast iron.
  - Lead based & Tin based Babbitt's are available.
  - Excellent conformability and embeddability
  - Good corrosion resistance.
  - Poor fatigue strength
- **Copper Based alloys** - most common alloys are copper tin, copper lead, phosphor bronze: harder and stronger than white metal: can be used **un-backed as a solid bearing**.
- **Aluminum based alloys** - running properties not as good as copper based alloys but cheaper.
  - **Ptfe** - suitable in very light applications
  - **Sintered bronze** - Sintered bronze is a porous material which can be impregnated with oil, graphite or Ptfe. Not suitable for heavily loaded applications but useful where lubrication is inconvenient.
- **Nylon** - similar to Ptfe but slightly harder: used only in very light applications.

Triple-layer composite bearing material consists of 3 bonded layers: steel backing, sintered porous tin bronze interlayer and anti-wear surface as shown in figure 1.15. High load capacities and low friction rates, and are oil free and anti-wear.

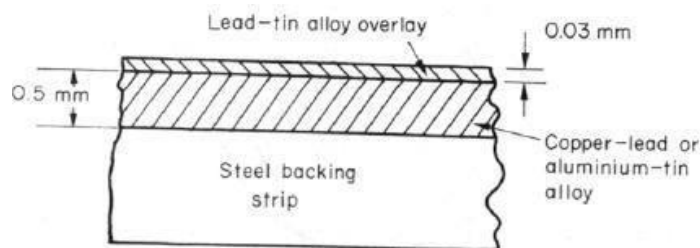

Fig.1.15 Tri-metal Bearing

If oil supply fails, frictional heating will rapidly increase the bearing temperature, normally lead to metal-to-metal contact and eventual seizure. Soft bearing material (low melting point) will be able to shear and may also melt locally. **Protects the journal** from severe surface damage, and helps to avoid component breakages (sudden locking of mating surfaces).

## 1.8 Petroff's Equation for lightly Loaded Bearings

The phenomenon of bearing friction was first explained by Petroff on the assumption that the shaft is concentric. This can happen when the radial load acting on the bearing is zero or very small, speed of the journal is very high and the viscosity of the lubricant is very high. Under these conditions, the eccentricity of the bearing (the offset between journal center and bearing center) is very small and the bearing could be treated as a concentric bearing as shown in figure 1.16

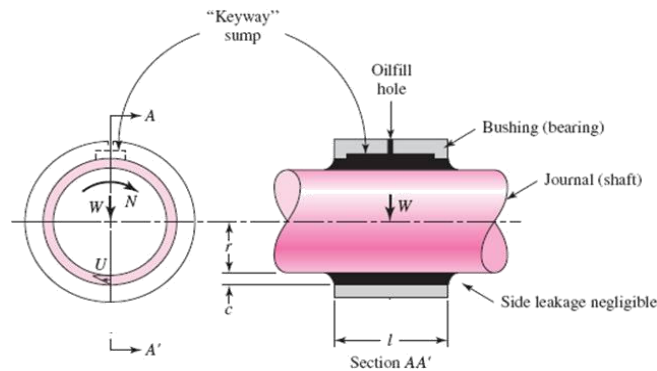

Fig.1.16 Concentric Bearing

Let us now consider a shaft rotating in a guide bearing. It is assumed that the bearing carries a very small load, that the clearance space is completely filled with oil, and that leakage is negligible (Fig. 7.16). Let the radius of the shaft be  $r$ , and the length of the bearing by  $l$ . If the shaft rotates at  $N'$  rev/s, then its surface velocity is  $U = 2\pi r N'$ . Since the shearing stress in the lubricant is equal to the velocity gradient times the viscosity,

$$\tau = Z U/h = 2\pi r N' Z/c$$

where the radial clearance  $c$  has been substituted for the distance  $h$ .

$$F = \text{Frictional force} = \tau A = (2\pi r N' Z/c) (2\pi r l) = (4\pi^2 r^2 l Z N'/c)$$

$$\text{Frictional torque} = Fr = (4\pi^2 r^3 l Z N'/c)$$

The coefficient of friction in a bearing is the ratio of the frictional force  $F$  to the Radial load  $W$  on the bearing.

$$f = F/W = (4\pi^2 r^3 l Z N'/cW)$$

The unit bearing pressure in a bearing is given by  $p = W/2rL = \text{Load/Projected Area of the Bearing}$ .

$$\text{Or } W = 2\pi r L p$$

Substituting this in equation for  $f$  and simplifying

$$f = 2u^2 (ZN'/p) (r/c)$$

This is the Petroff's equation for the coefficient of Friction in Lightly Loaded bearings.

### Example on lightly loaded bearings

E1. A full journal bearing has the following specifications:

- Journal Diameter: 46 mm
- Bearing length: 66 mm
- Radial clearance to radius ratio: 0.0015
- speed : 2800 r/min
- Radial load: 820 N.
- Viscosity of the lubricant at the operating temperature: 8.4 cP

Considering the bearing as a lightly loaded bearing, Determine (a) the friction torque (b) Coefficient of friction under given operating conditions and (c) power loss in the bearing.

#### Solution:

Since the bearing is assumed to be a lightly loaded bearing, Petroff's equation for the coefficient of friction can be used.

$$f = 2u^2 (ZN'/p) (r/c)$$

$$N = 2800/60 = 46.66 \text{ r/sec.}$$

$$Z = 8.4 \text{ cP} = 8.4 \times 10^{-3} \text{ Pa.sec r}$$

$$= 46/2 = 23 \text{ mm} = 0.023 \text{ m}$$

$$P = w/2rL = 820 / (2 \times 0.023 \times 0.066) = 270092 \text{ Pa.}$$

Substituting all these values in the equation for f,  $f = 0.019$

T = Frictional torque: Frictional force x Radius of the Journal

$$= (f W) r$$

$$= 0.019 \times 820 \times 0.023$$

$$= \mathbf{0.358 \text{ N-m}}$$

$$= 0.358 \times 46.66 / 1000$$

$$= \mathbf{0.016 \text{ kW}}$$

## 1.9 HYDRODYNAMIC JOURNAL BEARINGS

### Concept

The film pressure is created by the moving surface itself pulling the lubricant into a wedge-shaped zone at a velocity sufficiently high to create the pressure necessary to separate the surfaces against the load on the bearing.

One type occurs when the rate of shear across the oil film is a constant value and the line representing the velocity distribution is a straight line. In the other type the velocity distribution is represented by a curved line, so that the rate of shear in different layers across the oil film is different. The first type takes place in the case of two parallel surfaces having a relative motion parallel to each other as shown in Fig.1.19.

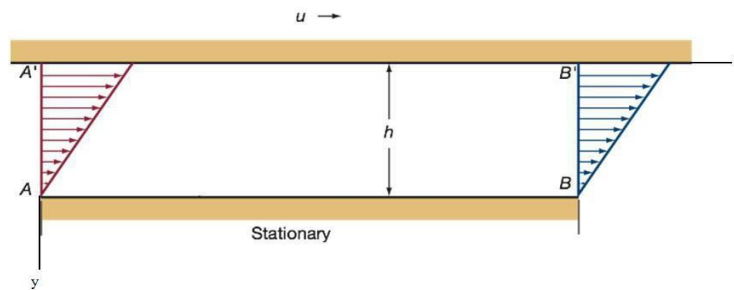

Fig. 1.19 Velocity profiles in a parallel-surface slider bearing.

There is no pressure development in this film. This film cannot support an external Load.

The second type of velocity distribution across the oil film occurs if pressure exists in the film. This pressure may be developed because of the change of volume between the surfaces so that a lubricant is squeezed out from between the surfaces and the viscous resistance of flow builds up the pressure in the film as shown in Fig 1.20 or the pressure may be developed by other means that do not depend upon the motion of the surfaces or it may develop due to the combination of factors. What is important to note here is the fact that pressure in the oil film is always present if the velocity distribution across the oil film is represented by a curved line

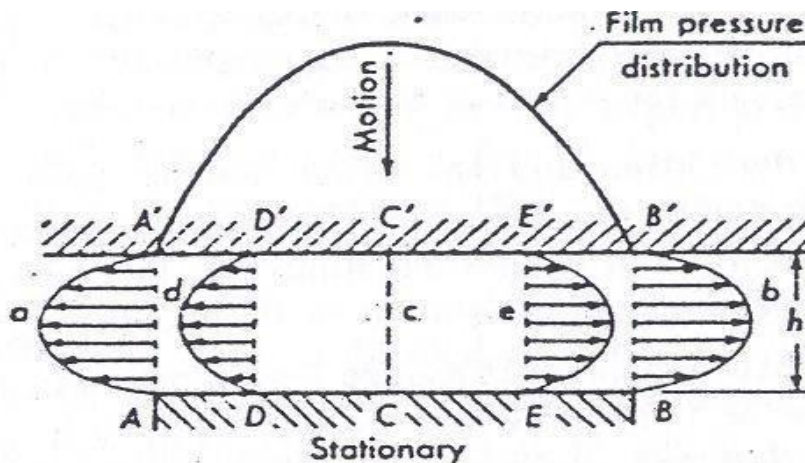

FIG. 1.20 FLOW BETWEEN TWO PARALLEL SURFACE

Plate AB is stationary while A' B' is moving perpendicular to AB.  
 Note that the velocity distribution is Curvilinear. This is a pressure induced flow.  
 This film can support an External load.

**Hydrodynamic film formation**

Consider now the case of two non parallel planes in which one is stationary while the other is in motion with a constant velocity in the direction shown in Fig 1.21. Now consider the flow of lubricant through the rectangular areas in section AA' and BB' having a width equal to unity in a direction perpendicular to the paper.

The volume of the lubricant that the surface A'B' tends to carry into the space between the surfaces AB and A'B' through section AA' during unit time is AC'A'. The volume of the lubricant that this surface tends to discharge from space through section BB' during the same period of time is BD'B'. Because the distance AA' is greater than BB' the volume AC'A' is greater than volume BC'B' by a volume AEC'. Assuming that the fluid is incompressible and that there is no flow in the direction perpendicular to the motion, the actual volume of oil carried into the space must be equal to the discharge from this space. Therefore the excess volume of oil is carried into these space is squeezed out through the section AA' and BB' producing a constant pressure – induced flow through these sections.

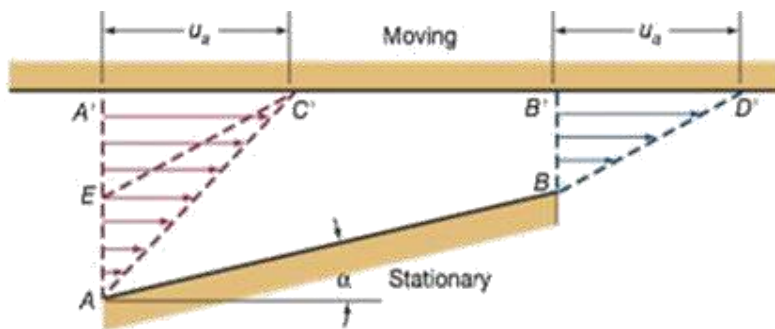

Fig.1.21 Velocity distribution only due to moving plate

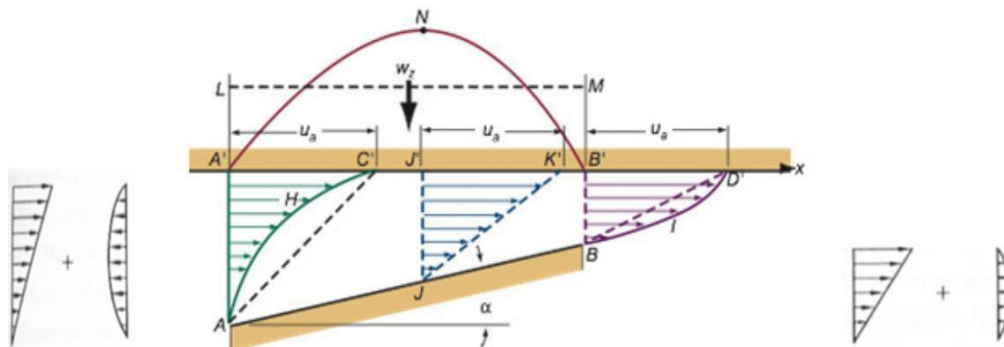

Fig.1.22 Resultant Velocity Distribution

The actual velocity distribution in section AA' and BB' is the result of the combined flow of lubricant due to viscous drag and due to pressure-induced flow. The resultant velocity distributions across these sections are as shown in Fig 1.22.

The curve A'NB' shows the general character of the pressure distribution in the oil film and the line LM shows the mean pressure in the oil film. Because of the pressure developed in the oil film the, plane A'B' is able to support the vertical load W applied to this plane, preventing metal to metal contact between the surfaces AB and A'B'. This load is equal to the product of projected area of the surface AB and mean pressure in the oil film.

### Conditions to form hydrodynamic lubrication

There must be a wedge-shaped space between two relative moving plates;

There must be a relative sliding velocity between two plates, and the lubricant must flow from big entrance to small exit in the direction of the moving plate;

The lubricant should have sufficient viscosity, and the supply of the lubricant is abundant.

### Formation of oil film in a Journal bearing

Imagine a journal bearing with a downward load on the shaft that is initially at rest and then brought up to operating speed. At rest (or at slow shaft speeds), the journal will contact the lower face of the bearing as shown in the figure 1.23. This condition is known as boundary lubrication and considerable wear can occur. As shaft speed increases, oil dragged around by the shaft penetrates the gap between the shaft and the bearing so that the shaft begins to "float" on a film of oil. This is the transition region and is known as thin-film lubrication. The journal may occasionally contact the bearing particularly when shock radial load occur. Moderate wear may occur at these times. At high speed, the oil film thickness increases until there comes a point where the journal does not contact the bearing at all. This is known as thick film lubrication and no wear occurs because there is no contact between the journal and the bearing.

The various stages of formation of a hydrodynamic film is shown in figure 1.23.

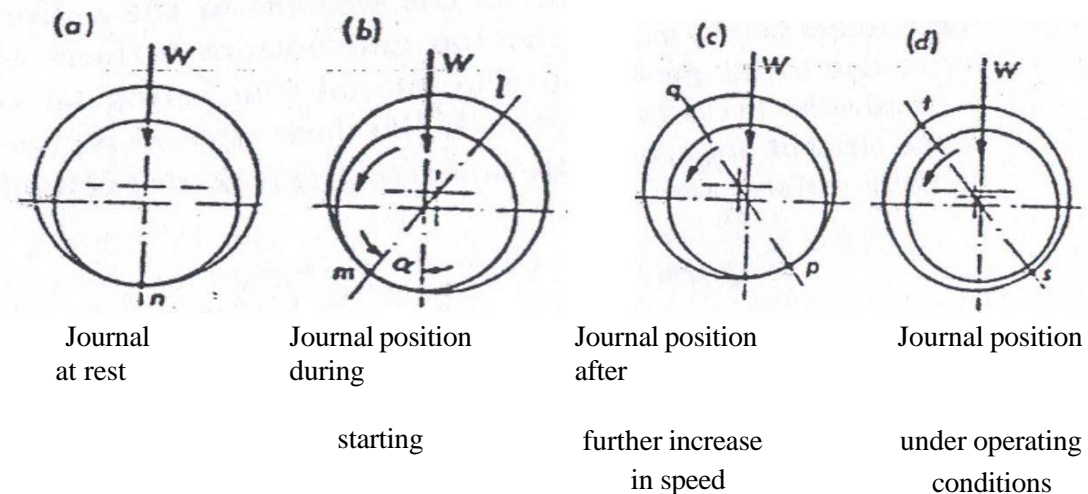



### Pressure distribution around an idealised journal bearing

A typical pressure distribution around the journal in a hydrodynamic bearing is as shown in the Fig. 1.24.

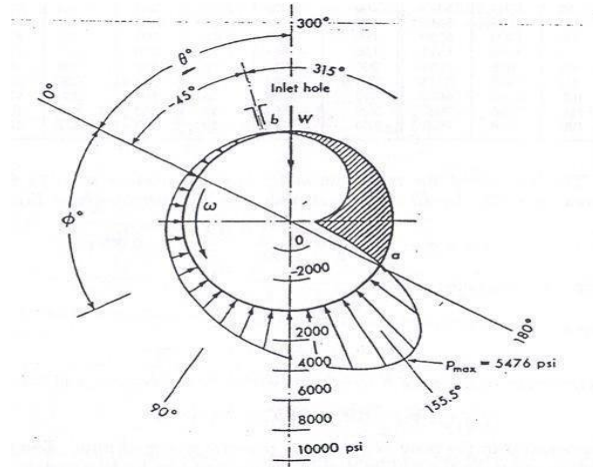
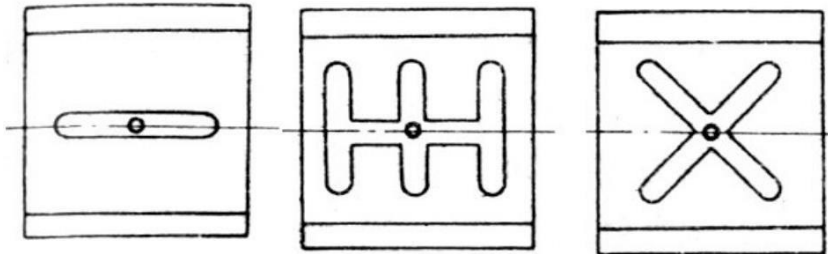

Fig.1.24 Bearing pressure distribution in a journal bearing

### Typical oil groove patterns



Some typical groove patterns are shown in the above figure. In general, the lubricant may be brought in from the end of the bushing, through the shaft, or through the bushing. The flow may be intermittent or continuous. The preferred practice is to bring the oil in at the center of the bushing so that it will flow out both ends, thus increasing the flow and cooling action.

### 1.13 Thermal aspects of bearing design

Heat is generated in the bearing due to the viscosity of the oil. The frictional heat is converted into heat, which increases the temperature of the lubricant. Some of the lubricant that enters

the bearing emerges as a side flow, which carries away some of the heat. The balance of the lubricant flows through the load-bearing zone and carries away the balance of the heat generated. In determining the viscosity to be used we shall employ a temperature that is the average of the inlet and outlet temperatures, or

$$T_{av} = (T_i + T_o) / 2$$

where  $T_i$  is the inlet temperature and  $T_o$  is the temperature rise of the lubricant from inlet to outlet. The viscosity used in the analysis must correspond to  $T_{av}$ .

**Self contained bearings:**

These bearings are called *self-contained* bearings because the lubricant sump is within the bearing housing and the lubricant is cooled within the housing. These bearings are described as *pillow-block* or *pedestal* bearings. They find use on fans, blowers, pumps, and motors, for example. Integral to design considerations for these bearings is dissipating heat from the bearing housing to the surroundings at the same rate that enthalpy is being generated within the fluid film.

**Heat dissipated based on the projected area of the bearing:**

Heat dissipated from the bearing, J/S      $H_D = CA (t_B - t_A)$

Where C= Heat dissipation coefficient from data hand book

Another formula to determine the heat dissipated from the bearing

$$H_D = ld (T + 18)^2 / K_3$$

Where  $K_3 = 0.2674 \times 10^6$  for bearings of heavy construction and well ventilated =  $0.4743 \times 10^6$  for bearings of light construction in still air

$$T = t_B - t_A$$

Where,

$t_B$  = Bearing surface temperature  $t_A$  = Ambient temperature

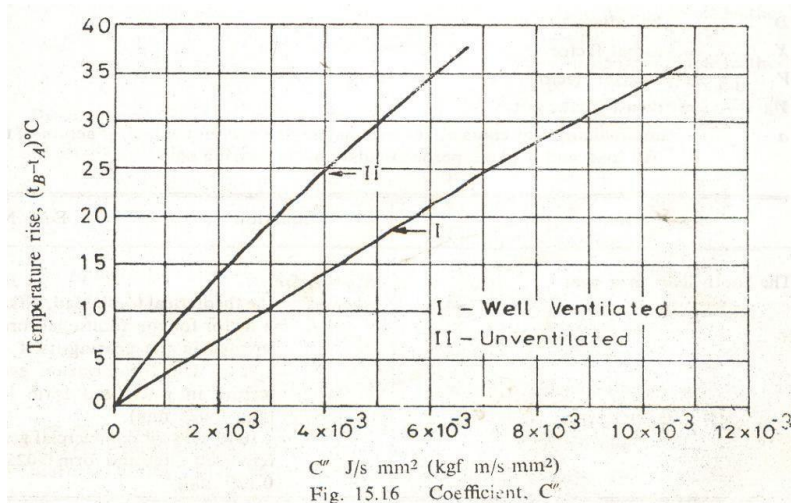

Fig. 15.16 Coefficient,  $C''$

For good performance the following factors should be considered.

**Surface finish of the shaft (journal):** This should be a fine ground finish and preferably lapped.

**Surface hardness of the shaft:** It is recommended that the shaft be made of steel containing at least 0.35-0.45% carbon. For heavy duty applications shaft should be hardened.

**Grade of the lubricant:** In general, the higher the viscosity of the lubricant the longer the life. However the higher the viscosity the greater the friction, so high viscosity lubricants should only be used with high loads. In high load applications, bearing life may be extended by cutting a grease groove into the bearing so grease can be pumped in to the groove.

**Heat dissipation:** Friction generates heat and causes rise in temperature of the bearing and lubricant. In turn, this causes a reduction in the viscosity of the lubricating oil and could result in higher wear. Therefore the housing should be designed with heat dissipation in mind. For example, a bearing mounted in a Bakelite housing will not dissipate heat as readily as one mounted in an aluminium housing.

**Shock loads:** Because of their oil-cushioned operation, sliding bearings are capable of operating successfully under conditions of moderate radial shock loads. However excessive prolonged radial shock loads are likely to increase metal to metal contact and reduce bearing life. Large out of balance forces in rotating members will also reduce bearing life.

**Clearance:** The bearings are usually a light press fit in the housing. A shouldered tool is usually used in arbour press. There should be a running clearance between the journal and the bush. A general rule of thumb is to use a clearance of 1/1000 of the diameter of the journal.

**Length to diameter ratio(l/d ratio):** A good rule of thumb is that the ratio should lie in the range 0.5-1.5. If the ratio is too small, the bearing pressure will be too high and it will be difficult to retain lubricant and to prevent side leakage. If the ratio is too high, the friction will be high and the assembly misalignment could cause metal to metal contact.

### **Examples on journal bearing design**

#### **Example EI:**

Following data are given for a 360° hydrodynamic bearing:

Radial load=3.2 kN

Journal speed= 1490 r.p.m.

Journal diameter=50 mm

Bearing length=50mm Radial  
clearance=0.05 mm

Viscosity of the lubricant= 25 cP

Assuming that the total heat generated in the bearing is carried by the total oil flow in the bearing, calculate:

- Power lost in friction;
- The coefficient of friction;
- Minimum oil film thickness
- Flow requirement in l/min; and
- Temperature rise.

#### **Solution:**

$$P = W/Ld = 3.2 \times 1000 / (50 \times 50) = 1.28 \text{ MPa} = 1.28 \times 10^6$$

$$\text{Pa Sommerfeld number} = S = (ZN^4/p) (r/c)^2$$

$$r/c = 25/0.05 = 500$$

$$Z = 25 \text{ cP} = 25 \times 10^{-3} \text{ Pa}\cdot\text{sec}$$

$$= 1490/60 = 24.833 \text{ r/sec. Substituting the above values, we get}$$

$$\mathbf{S = 0.121}$$

$$\text{For } S = 0.121 \text{ \& } L/d = 1,$$

$$\text{Friction variable from the graph} = (r/c) f = 3.22$$

$$\text{Minimum film thickness variable} = h_o / c = 0.4 \text{ Flow}$$

$$\text{variable} = Q/rcN^1L = 4.33$$

$$f = 3.22 \times 0.05 / 25 = 0.0064$$

$$\begin{aligned} \text{Frictional torque} = T &= fWr = 0.0064 \times 3200 \times 0.025 \\ &= 0.512 \text{ N}\cdot\text{m} \end{aligned}$$

$$\begin{aligned} \text{Power loss in the Bearing} &= 2\pi N^1 T / 1000 \text{ kW} \\ &= 0.080 \text{ kW} \end{aligned}$$

$$h_o = 0.4 \times 0.05 = 0.02 \text{ mm}$$

$$Q/rcN^1L = 4.33 \text{ from which we get,}$$

$$Q = 6720.5 \text{ mm}^3 / \text{sec.}$$

## Ex 2

Determination of dimensionless variables is shown in the following figures.

Assume that all the heat generated due to friction is carried away by the lubricating oil.

$$\text{Heat generated} = 80 \text{ watt} = mC_p T$$

where:

$$m = \text{mass flow rate of lubricating oil} = \rho Q \text{ in kg/sec } C_p =$$

$$\text{Specific heat of the oil} = 1760 \text{ J/kg } ^\circ\text{C}$$

$$T = \text{temperature rise of the oil } \rho =$$

$$860 \times 10^{-9} \text{ kg/mm}^3 \text{ Substituting the}$$

$$\text{above values, } T = 7.9 \text{ } ^\circ\text{C}$$

$$\text{The Average temperature of the oil} = T_i + T/2 = 27 + (7.9/2) = 30.85 \text{ } ^\circ\text{C}$$

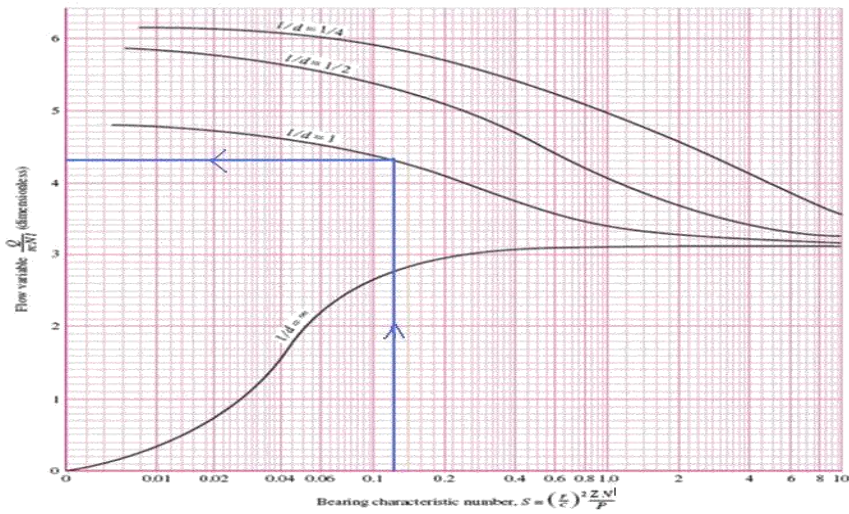
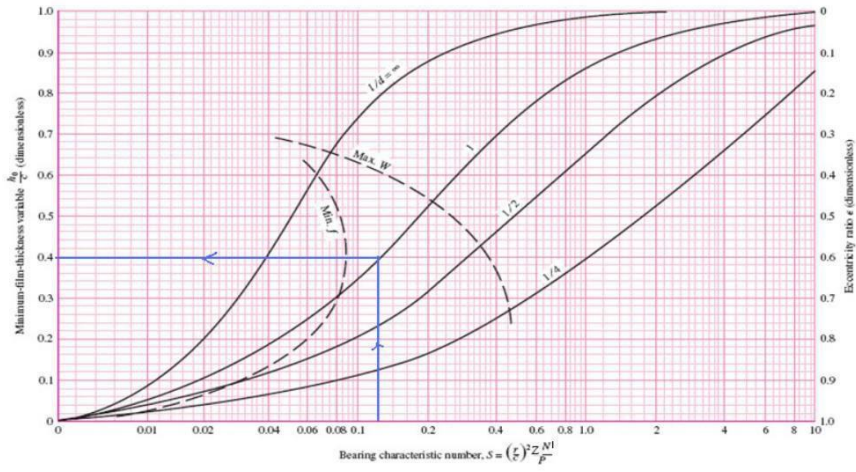
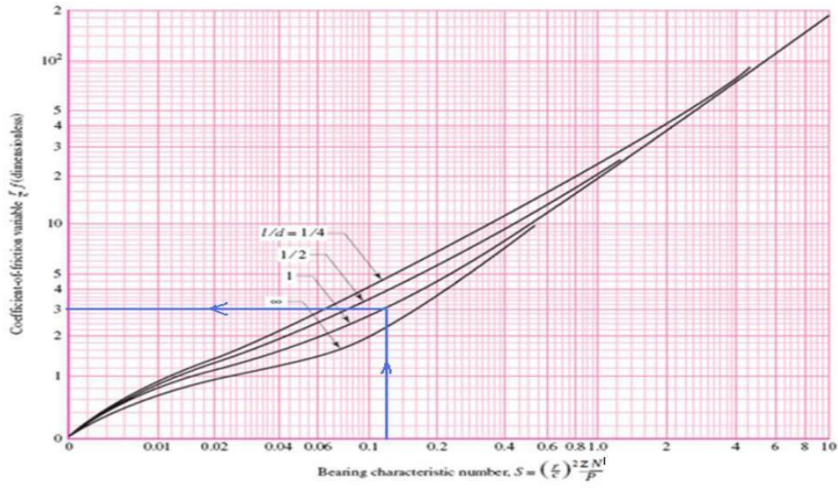

### **Example E2:**

A 50 mm diameter hardened and ground steel journal rotates at 1440 r/min in a lathe turned bronze bushing which is 50 mm long. For hydrodynamic lubrication, the minimum oil film thickness should be five times the sum of surface roughness of journal bearing. The data about machining methods are given below:

	Machining method	surface	Roughness(c.l.a)
Shaft	grinding		1.6 micron
Bearing	turning/boring		0.8 micron

The class of fit is H8d8 and the viscosity of the lubricant is 18 cP. Determine the maximum radial load that the journal can carry and still operate under hydrodynamic conditions.

### **Solution:**

Min. film thickness =  $h_o = 5 [0.8 + 1.6] = 12 \text{ micron} = 0.012 \text{ mm}$

For H8 d8 fit, referring to table of tolerances,

$\text{Ø}50 \text{ H8} = \text{Min. hole limit} = 50.000 \text{ mm Max.}$

hole limit = 50.039 mm

Mean hole diameter = 50.0195 mm

$\text{Ø}50 \text{ d8} = \text{Max. shaft size} = 50 - 0.080 = 49.920$

mm Min. shaft size = 50 - 0.119 = 49.881 mm Mean

shaft diameter = 49.9005 mm.

Assuming that the process tolerance is centered, Diametral

clearance = 50.0195 - 49.9005 = 0.119 mm Radial

clearance = 0.119/2 = 0.0595 mm

$h_o / c = 0.012 / 0.0595 = 0.2 \text{ L/d}$

= 50/50 = 1

From the graph, Sommerfeld number = 0.045

$$\underline{S = (ZN'/\rho) (r/c)^2 = 0.045}$$

$$r/c = 25/0.0595 = 420.19$$

$$Z = 18 \text{ cP} = 18 \times 10^{-3} \text{ Pa}\cdot\text{sec}$$

$$N' = 1440/60 = 24 \text{ r/sec}$$

From the above equation, Bearing pressure can be calculated.  $p =$

$$1.71 \times 10^9 \text{ Pa} = 1.71 \text{ MPa.}$$

The load that the bearing can carry:

$$\underline{W = pLd = 1.71 \times 50 \times 50 = 4275 \text{ N}}$$

**Example E3:**

The following data are given for a full hydrodynamic journal bearing: Radial load=25kN  
Journal speed=900 r/min.  
Unit bearing pressure= 2.5 MPa  
(l/d) ratio= 1:1  
Viscosity of the lubricant=20cP Class  
of fit=H7e7

Calculate: 1. Dimensions of bearing  
2. Minimum film thickness and  
3. Requirement of oil flow

**Solution:**

$$N' = 900/60 = 15 \text{ r/sec } P = W/Ld$$

$$2.5 = 25000/Ld = 25000/d^2$$

As  $L=d$ .

$$\mathbf{d = 100 \text{ mm} \ \& \ L = 100 \text{ mm}}$$

For H7 e7 fit, referring to table of tolerances,  $\varnothing 100$

$$H7 = \text{Min. hole limit} = 100.000 \text{ mm}$$

$$\text{Max. hole limit} = 100.035 \text{ mm Mean}$$

$$\text{hole diameter} = 100.0175 \text{ mm}$$

$$\varnothing 100 \text{ e7} = \text{Max. shaft size} = 100 - 0.072 = 99.928$$

$$\text{mm Min. shaft size} = 100 - 0.107 =$$

$$99.893 \text{ mm}$$

$$\text{Mean shaft diameter} = 99.9105 \text{ mm}$$

**Assuming that the process tolerance is centered, Diametral clearance= 100-0175- 99.9105= 0.107 mm Radial clearance= 0.107/2= 0.0525mm**

Assume  $r/c = 1000$  for general bearing applications.  $C =$

$$r/1000 = 50/1000 = 0.05 \text{ mm.}$$

$$Z = 20 \text{ cP} = 20 \times 10^{-3} \text{ Pa.sec}$$

$$N' = 15 \text{ r/sec}$$

$$P = 2.5 \text{ MPa} = 2.5 \times 10^6 \text{ Pa}$$

$$\mathbf{S = (ZN'/\rho) (r/c)^2 = 0.12}$$

For  $L/d=1$  &  $S=0.12$ , Minimum Film thickness variable=  $h_o/c = 0.4$

$$\mathbf{h_o = 0.4 \times 0.05 = 0.02 \text{ mm}}$$

**Example E4:**

A journal bearing has to support a load of 6000N at a speed of 450 r/min. The diameter of the journal is 100 mm and the length is 150mm. The temperature of the bearing surface is limited to 50 °C and the ambient temperature is 32 °C. Select a suitable oil to suit the above conditions.

**Solution:**

$N^1 = 450/60 = 7.5$  r/sec,  $W=6000$  N,  $L=150$ mm,  $d=100$  mm,  $t_A = 32$  °C,  $t_B = 50$  °C.

Assume that all the heat generated is dissipated by the bearing.

Use the Mckee's Equation for the determination of coefficient of friction.  $f$ =Coefficient of

$$\text{friction} = K_a (ZN^1/p) (r/c) 10^{-10} + f$$

$$p = W/Ld = 6000/100 \times 150 = 0.4 \text{ MPa.}$$

$$K_a = 0.195 \times 10^6 \text{ for a full bearing } f = 0.002$$

$$r/c = 1000 \text{ assumed}$$

$$U = 2\pi rN^1 = 2 \times 3.14 \times 50 \times 7.5 = 2335 \text{ mm/sec} = 2.335 \text{ m/sec. } f = 0.195 \times 10^6 \times (Z * 7.5 / 0.4) \times 1000 \times 10^{-10} + 0.002$$

$$f = 0.365Z + 0.002$$

$$\text{Heat generated} = f * W * U$$

$$\text{Heat generated} = (0.365Z + 0.002) \times 6000 \times 2.335 \text{ Heat}$$

dissipated from a bearing surface is given by:

$$H_D = ld (T+18)^2 / K_3$$

$$\text{Where } K_3 = 0.2674 \times 10^6 \text{ for bearings of heavy construction and well ventilated} \\ = 0.4743 \times 10^6 \text{ for bearings of light construction in still air air}$$

$$T = t_B - t_A = 50 - 32 = 18^\circ\text{C}$$

$$H_D = 150 \times 100 (18+18)^2 / 0.2674 \times 10^6 = 72.7 \text{ Watt}$$

$$H_D = Hg \text{ for a self contained bearing.}$$

$$72.7 = (0.365Z + 0.002) \times 6000 \times 2.335 \text{ } Z = 0.0087 \text{ Pa.Sec.}$$

Relation between oil temp, Amb. temp, & Bearing surface temperature is given by

$$t_B - t_A = \frac{1}{2} (t_o - t_A)$$

$$t_o = \text{oil temperature} = 68^\circ\text{C}$$



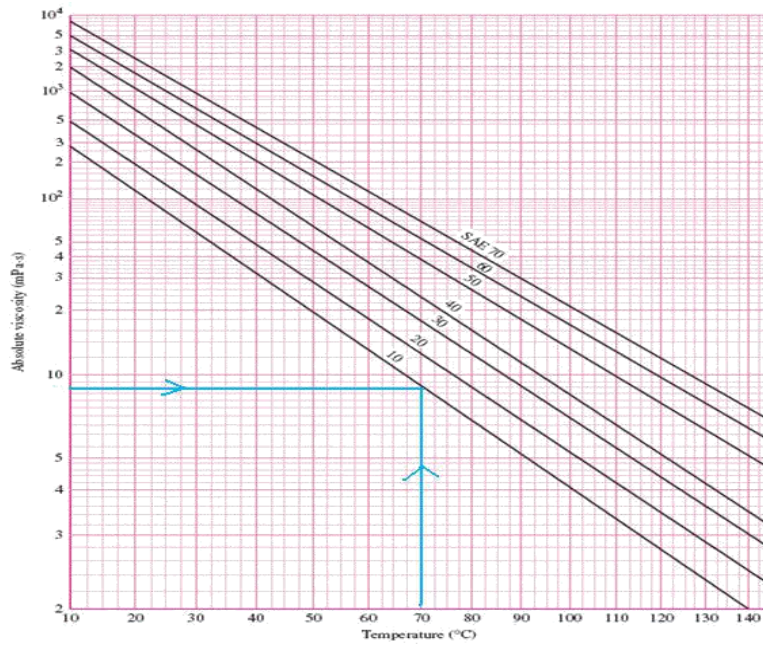

Select SAE 10 Oil for this application

## ASSIGNMENT QUESTIONS

### UNIT I

#### LONG ANSWERS

1. a) What are the general considerations in the design of machine elements?  
b) A cast iron pulley transmits 10 KW at 400 rpm. The diameter of the pulleys 1.2 meter and it has four straight arms of elliptical cross section. In which the major axis is twice the minor axis. Determine the dimensions of the arm if the allowable bending stress is 15MPa.  
c) Explain simple stresses
2. a) Explain Goodman failure .  
b) A circular bar of 0.5 m length is supported freely at its two ends. It is acted upon by a central concentrated cyclic load having a minimum value of 20 kN and a maximum value of 50 kN. Determine the diameter of bar by taking a factor of safety of 1.5, size factor of 0.85, surface finish factor of 0.9. The material properties of bar is given by : Ultimate strength of 650 MPa, Yield strength of 500 MPa and Endurance strength of 350 MPa.  
c) Draw S-N curve for mild steel and explain its significance.  
b) Explain briefly the various theory of failures.
1. a) Explain the modified Goodman diagram for bending stresses.  
b) A transmission shaft of cold drawn steel 27Mn2 ( $S_{ut} = 500 \text{ N/mm}^2$  and,  $S_{yt} = 30\text{N/mm}^2$ ) is subjected to a fluctuating torque which varies from -100 N-m to +400 N-m. The factor of safety is 2 and the expected reliability is 0%. Neglecting the effect of stress concentration, determine the diameter of the shaft. Assume the distortion energy theory of failure.
2. a) What are the manufacturing considerations in the design of Castings?  
b) A manufacturer is interested to start his business with five different models of tractors ranging from 7.5 to 75 KW capacities. Specify power capacities of models. There is an expansion plan to further increase the number of models from five to nine to fulfill the requirements of the farmers. Specify the power capacities of additional models.
3. a) Explain briefly about Soderberg and Goodman lines with neat sketches.  
b) A circular bar of 500 mm length is supported freely at its two ends. It is acted upon by a central concentrated cyclic load having a minimum value of 20 KN and a maximum value of 50 KN. Determine the diameter of bar by taking a factor of safety of 1.5, size effect of 0.85, surface finish factor of 0.9. The material properties of bar are given by : Ultimate strength of 650 MPa, yield strength of 500 MPa and endurance strength of 350 MPa.

## UNIT II

4. a) Explain briefly about the preferred numbers.  
b) A cantilever cold drawn steel bar 20 mm diameter and 100 mm length is loaded by a transverse force of 0.55 kN, an axial load of 8 kN and a torque of 30 Nm. The yield tensile and compressive strength are 165 MPa and 190MPa. Compute factor of safety based on Maximum shear stress theory and Maximum distortion energy theory.
  
5. a) Draw the Gerber curve, Goodman and Soderberg lines with neat sketch and explain its significance.  
b) A solid circular shaft made of steel Fe620 ( $S_{ut} = 620 \text{ N/mm}^2$  and  $S_{yt} = 380 \text{ N/mm}^2$ ) is subjected to an alternating torsional moment, that varies from -200N-m to +400 N-m. The shaft is ground and the expected reliability is 90%. Neglecting the stress concentration, Calculate the shaft diameter for infinite life. The factor of safety is 2. Use the distortion energy theory of failure.
  
6. a) Explain briefly about the torsional and bending stresses in the design of machine elements.  
b) A cylindrical shaft made of steel of yield strength 700 MPa is subjected to static loads consisting of bending moment 10kN-m and a torsional moment of 30kN-m. Determine the diameter of shaft using all theories of failure and assuming a factor of safety of 2. Take  $E = 210 \text{ GPa}$  and Poisson's ratio = 0.25.
  
7. a) Estimate the factors that affect the fatigue strength.  
b) A simply supported beam has a point load at the centre which fluctuates from a value  $F$  to  $4F$ . Length of beam is 500 mm and cross section is circular with a diameter of 60 mm. Ultimate, yield stresses are 700 MPa and 500 MPa respectively. Endurance limit in reverse bending is 330 MPa. Factor of safety desired is 1.3. Assume size factor 0.83, Surface finish factor 0.9, reliability factor 1.0. Find the maximum value of  $F$ .
  
8. a) Explain the manufacturing considerations in design.  
b) State and explain various theories of failure under static loading.  
c) Find the diameter of shaft required to transmit 60 kW at 150 rpm if the maximum torque is likely to exceed the mean torque by 25% for a maximum permissible torsional shear stress of  $60 \text{ N/mm}^2$ . Also find the angle of twist for a length of 2.5 meters. Take  $G = 80 \text{ GPa}$ .
  
9. a) Explain the types of fluctuating stresses.  
b) A hot rolled steel shaft is subjected to a torsional moment that varies from +350 Nm to -115 Nm and an applied bending moment at a critical section varies from 445 Nm to 225 Nm. The shaft is of uniform cross section. Determine the required shaft diameter. The material has an ultimate strength of 550 MPa and yield strength of 410 MPa. Take the endurance limit as half the ultimate strength, factor of safety of 2, size factor of 0.85 and a surface finish factor of 0.62. (Using Goodman's Line).
  
10. a) What is the difference between caulking and fullering? Explain with the help of neat sketches.  
b) Design a triple riveted longitudinal double strap butt joint with unequal straps for a boiler. The inside diameter of the drum is 1.3 meters. The joint is to be designed for a

steam pressure of  $2.4 \text{ N/mm}^2$ . The working stresses to be used are  $\sigma_t=77\text{N/mm}^2$ ,  $\tau=62 \text{ N/mm}^2$ ;  $\sigma_c=120 \text{ N/mm}^2$ . Assume the efficiency of the joint as 81 %.

11. Find the diameter of shaft required to transmit 60 kW at 150 rpm if the maximum torque is likely to exceed the mean torque by 25% for a maximum permissible torsional shear stress of  $60 \text{ N/mm}^2$ . Also find the angle of twist for a length of 2.5 meters. Take  $G = 80 \text{ GPa}$ .
  
12. a) Explain the causes of stress concentration.  
b) A circular cross section cantilever beam having length 130 mm. subjected to a cyclic transverse load of varying form -150 N to 350 N, FOS is 2, theoretical stress concentration factor is 1.4, notch sensitivity factor is 0.9, ultimate strength is 540 MPa, yield strength is 320 MPa. Size correction factor is 0.85. Endurance limit is 275 MPa, surface correction factor is 0.9 and notch sensitivity factor is 0.9. Determine the diameter of the beam by (i) Goodman method and (ii) Soderberg method.
  
13. a) Discuss various theories of failure.  
b) Find the diameter of shaft required to transmit 60 kW at 150 rpm if the maximum torque is likely to exceed the mean torque by 25% for a maximum permissible torsional shear stress of  $60 \text{ N/mm}^2$ . Also find the angle of twist for a length of 2.5 meters. Take  $G = 80 \text{ GPa}$ .
  
14. a) Explain the factors that affect the fatigue strength.  
b) A machine member is made of plain carbon steel of ultimate strength  $650 \text{ N/mm}^2$  and endurance limit of  $300 \text{ N/mm}^2$ . The member is subjected to a fluctuating torsional moment which varies from -200 Nm to 400 Nm. Design the member using (i) modified Goodman's equation and (ii) Soderberg equation.
  
15. a) A shaft is required to transmit 1 MW power at 240 rpm. The shaft must not twist more than  $1^\circ$  on a length of 15 diameters. If the modulus of rigidity for material of the shaft is 80 GPa, find the diameter of the shaft and shear stress induced.  
  
b) A bolt is subjected to a direct tensile load of 20 kN and a shear load of 15 kN. Suggest the suitable size of bolt according to various theories of elastic failure, if the yield stress in simple tension is 360 MPa. A factor of safety of 3.5 should be used. Take Poisson's ratio as 0.25.
  
16. a) Explain the factors that affect the fatigue strength.  
  
b) A machine member is made of plain carbon steel of ultimate strength  $650 \text{ N/mm}^2$  and endurance limit of  $300 \text{ N/mm}^2$ . If the member is subjected to a fluctuating torsional moment which varies from -200 N-m to 400 N-m. Design the member using (i) modified Goodman's equation and (ii) Soderberg equation.

## UNIT III

### LONG ANSWERS

1. a) Explain briefly the design considerations of welded assemblies.  
b) How the strength of transverse fillet weld is evaluated?  
c) A steel plate, 80 mm wide and 10 mm thick, is joined to another steel plate by means of a single transverse and double parallel fillet weld, as shown below Fig. 1. The strength of the welded joint should be equal to the strength of the plate to be joined. The permissible tensile and shear stresses for the weld material and the plates are 100 MPa and 70 MPa respectively. Find the length of each parallel fillet weld. Assume that the tensile force passes through the centre of gravity of three welds.

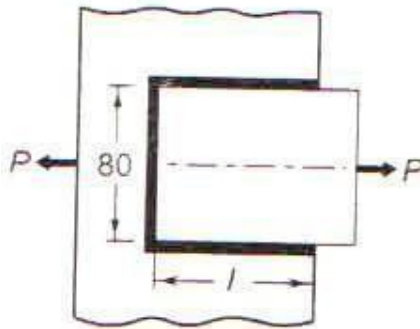

2. a) Explain the design procedure for the eccentrically loaded bolted joint.  
b) Design a double riveted butt joint with two cover plates for the longitudinal seam of a boiler shell 1.5 m in diameter subjected to a steam pressure of  $0.95 \text{ N/mm}^2$ . Assume joint efficiency as 75 % , allowable tensile stress in the plate 90 MPa, compressive stress 140 MPa and shear stress in the rivet is 56 MPa
3. a) Explain briefly the design of welded joints subjected to twisting moment and the bending moment.  
b) A circular shaft, 75 mm in diameter, is welded to the support by means of a circumferential fillet weld. It is subjected to a torsional moment of 3000 N-m. Determine the size of the weld, if the maximum shear stress in the weld is not to exceed  $70 \text{ N/mm}^2$ .
4. a) What are the advantages and disadvantages of welded joints?  
b) A 65 mm diameter solid shaft is to be welded to a flat plate by a fillet weld around the circumference of the shaft. Determine the size of the weld if the torque on the shaft is 3 kNm and the allowable shear stress in the weld is 70 MPa.
5. a) A bolt is subjected to a direct tensile load of 20 kN and a shear load of 15 kN. Suggest the suitable size of bolt according to various theories of elastic failure, if the

yield stress in simple tension is 360 MPa. A factor of safety of 3.5 should be used. Take Poisson's ratio as 0.25.

6. a) Explain the bolts of uniform strength.  
b) A steam engine of effective diameter 300 mm is subjected to a steam pressure of  $1.5 \text{ N/mm}^2$ . The cylinder head is connected by 8 bolts having yield point  $330 \text{ N/mm}^2$  and endurance limit at  $240 \text{ N/mm}^2$ . The bolts are tightened with an initial preload of 1.5 times the steam load. Assume a factor of safety 2. Find the size of bolt required the stiffness factor for copper gasket may be taken as 0.5.
7. a) Explain with sketches the different types of failures and efficiencies of the riveted joints.  
b) Two MS tie bars for a bridge structure are to be joined by means of a butt joint with double straps. The thickness of the tie bar is 12 mm and carries a load of 400 kN. Design the joint completely taking allowable stresses as 100 MPa in tension, 70 MPa in shear and 150 MPa in compression.
8. a) Discuss the advantages and disadvantages of riveted, bolted and welded joints.  
b) Design a cotter joint of socket and spigot type which is subjected to a pull and push of 50 kN. All the parts of the joint are made of the same material with the permissible stress as 70 MPa in tension, 100 MPa in compression and 40 MPa in shear.
9. a) Explain briefly design procedure for circumference lap joint for a boiler.  
b) Design a triple riveted longitudinal butt joint with unequal cover plates for a boiler seam. The diameter of the boiler is 2 m and the internal pressure is 2 MPa. The working stresses are 70 MPa in tension, 50 MPa in shear and 120 MPa in compression and the required efficiency of the joint is 80%.

## **UNIT IV**

### **LONG ANSWERS**

1. a) Briefly explain the procedure to design a shaft based on any two theories of failures.  
b) It is required to design a knuckle joint to connect circular shafts subjected to an axial force of 50 kN. The rods are coaxial and a small amount of angular movement between their axes is permissible. Design the joint and specify the dimensions of its components. The allowable tensile, compressive and shear stress in the rod and pin material is limited to 80MPa, 100MPa and 40MPa respectively.

2. a) Explain types of couplings.  
b) A mild steel shaft has to transmit 70 kW at 240 rpm. The allowable shear stress in the shaft material is limited to 45MPa. Design a cast iron flange coupling. The shear stress in the coupling bolt is limited to 30MPa.
3. a) A shaft, 40 mm in diameter is transmitting 35 KW power at 300 rpm by means of Kennedy keys of 10X10 mm cross section. The keys are made of steel 45C8 ( $S_{yt} = S_{yc} = 380 \text{ N/mm}^2$ ) and the factor of safety is 3. Determine the required length of the keys.  
b) Design a sleeve and cotter joint to resist a tensile load of 60 KN. All parts of the joint are made of the same material with the following allowable stresses.  $\sigma_t = 60 \text{ MPa}$  ,  $\tau = 70 \text{ MPa}$  and  $\sigma_c = 125 \text{ MPa}$ .
4. a) Explain the design procedure for flexible coupling.  
b) Design a Cast Iron flange coupling for a steel shaft transmitting 15 KW at 200 rpm and having an allowable shear stress of 40 MPa. The working stress in the bolts should not exceed 30 MPa. Assume that the same material is used for shaft and key and that the crushing stress is twice the value of its shear stress. The maximum torque is 25 % greater than the full load torque. The shear stress for Cast Iron is 14 MPa.
5. a) Explain briefly about the design of shafts subjected to combined bending and torsion.  
b) A line shaft is to transmit 30 KW at 160 rpm. It is driven by a motor placed directly under it by means of a belt running on a 1m diameter pulley keyed to the end of the shaft. The tension in the tight side of the belt is 2.5 times that of the slack side and the centre of pulley overhangs 150 mm beyond the centre line of the end bearing. Determine the diameter of the shaft, if the allowable shear stress is 56MPa and the pulley weighs 1600 N.
6. a) Explain about the design of Bushed pin flexible coupling with a neat sketch.  
b) Design a Cast Iron flange coupling for a mild steel shaft transmitting 90 KW at 250 rpm. The allowable shear stress in the shaft is 40 MPa and the angle of twist is not to exceed  $1^\circ$  in a length of 20 diameters. The allowable shear stress in the coupling bolts is 30 MPa.
7. a) Explain the design procedure for Muff Coupling.  
b) Design a Cast Iron flange coupling for a mild steel shaft transmitting 90 KW at 250 rpm. The allowable shear stress in the shaft is 40 MPa and the angle of twist is not to exceed  $1^\circ$  in a length of 20 diameters. The allowable shear stress in the coupling bolts is 30 MPa.
8. a) Write the design procedure for a flexible coupling  
b) Design a Muff coupling which is used to connect two steel shafts transmitting 40 KW at 350 rpm. The material for the shaft and key is plain carbon steel for which allowable shear and crushing stresses may be taken as

40MPa and 80MPa respectively. The material for the muff is cast iron for which the allowable shear stress may be assumed as 15MPa.

9. a) Compare weight, strength and stiffness of two shafts of same material, subjected to same torque. One being solid other being hollow with inner diameter to outer diameter ratio 0.5.  
b) Two shafts are connected by means of a flange coupling to transmit torque of 25 Nm. The two flanges of the coupling are fastened by four bolts of the same material at a radius of 30mm. Find the size of the bolts if the allowable shear stress for the bolt material is 30MPa.
10. Design a cast iron coupling for a mild steel shaft transmitting 90kW at 250 rpm. The allowable shear stress in the shaft is 40MPa and the angle of twist is not to exceed  $1^\circ$  in a length of 20 diameters. The allowable shear stress in the coupling bolts is 30MPa.
11. Design a rigid type of flange coupling to connect two shafts. The input shaft transmits 37.5kW power at 180 rpm to the output shaft through the coupling. The service factor for the application is 1.5. The design torque is 1.5times of rated torque. Select suitable materials for various parts of the coupling, design the coupling and specify the dimensions of the components.
12. Design a bushed pin type flexible coupling for connecting a motor shaft to a pump shaft for the following service conditions. Power to be transmitted = 40 kW, speed of the motor shaft = 1000 rpm. The material properties are : i) The allowable shear and crushing stress for shaft and key material is 40 MPa and 80 MPa respectively, ii) allowable shear stress for cast iron is 15 MPa, iii) Allowable bearing pressure for rubber bush is  $0.8 \text{ N/mm}^2$  and iv) the material of the pin is same as that of shaft and key. Draw neat sketch of the coupling.



## UNIT V

### LONG ANSWERS

1. a) Explain the design procedure for the socket and spigot joint.  
b) A circular steel bar 50 mm diameter and 200 mm long is welded perpendicularly to a steel plate to form a cantilever to be loaded with 5KN at the free end. Determine the size of the weld, assuming the allowable stress in the weld is 100 MPa.
  
2. a) Design a Knuckle joint to transmit 150 kN. The design stresses may be taken as 75 MPa in tension, 60 MPa in shear and 150 MPa in compression.  
b) Explain briefly a design of shafts subjected to combined bending and torsion.
  
3. a) Write the design procedure for Jib and Cotter joint for square rods.  
b) A mild steel shaft transmits 20 KW at 200 rpm. It carries a central load of 900 N and is simply supported between the bearings 2.5 m apart. Determine the size of the shaft, if the allowable shear stress is 42 MPa and the maximum tensile or compressive stress is not to exceed 56 MPa. What size of the shaft will be required, if it is subjected to gradually applied loads?
  
4. a) Explain different types of keys.  
b) Design a cotter joint to connect two mild steel rods for a pull of 30 kN. The maximum permissible stresses are  $55\text{N/mm}^2$  in tension,  $40\text{N/mm}^2$  in shear and  $70\text{N/mm}^2$  in crushing. Draw a neat sketch of the joint.
  
5. a) Explain stresses acting on keys.  
b) Design a cotter joint to connect two mild steel rods for a pull of 30 kN. The maximum permissible stresses are  $55\text{N/mm}^2$  in tension,  $40\text{N/mm}^2$  in shear and  $70\text{N/mm}^2$  in crushing. Draw a neat sketch of the joint.
  
6. Two tie rods are to be connected by means of a sleeve and two steel cotters. The rods are subjected to a tensile load of 40kN. Design the joint using the permissible stress in tension as 60MPa, in shear as 50MPa and in crushing as 120MPa. Draw a neat sketch and show all the dimensions.

# MALLA REDDY COLLEGE OF ENGINEERING & TECHNOLOGY

## DEPARTMENT OF MECHANICAL ENGINEERING

### III Year B. Tech, I Sem

#### MACHINE DESIGN-I(R17A0313)

##### *Proposed Projects for this subjects - I*

1. Collection of different kind of materials The material size should be 50 mm × 50mm
2. Create different wooden or steel model with different loading systems
3. Construct small load measuring device for Tensile and Compressive loads
4. Construct small load measuring device for fatigue load.
5. Demo modal for stress concentration and show how to remove or reduce stress concentration effect.
6. Prepare demo modal for different riveted joints and also show different rivets
7. Prepare demo modal for different welded joints and also show different weld connections
8. Prepare demo modal for different bolted joints and also show different bolts
9. Prepare different modal for different keys. The keys may be wooden or steel.
10. Prepare demo modal for different type cotter joint.
11. Prepare demo modal for knuckle joint.
12. Prepare demo modal for muff and split coupling.
13. Prepare demo modal for flange coupling.
14. Prepare demo modal for flexible coupling.
15. Design and fabricate any kind of simple machine.